

INTERNATIONAL DESIGN GUIDE



Contents

Built-In Refrigeration	3
PRO 48 Refrigeration	34
Integrated Refrigeration	39
Wine Storage	51

Features and specifications are subject to change at any time without notice. Visit subzero.com/specs for the most up-to-date information.

Built-In Refrigeration. For the built-in line, Sub-Zero designers and engineers took a fresh look at everything, inside and out. Exterior refinements include redesigned grilles and lower-profile hinges. Inside, new technology in food preservation makes the built-in line nothing short of revolutionary.

BUILT-IN MODELS

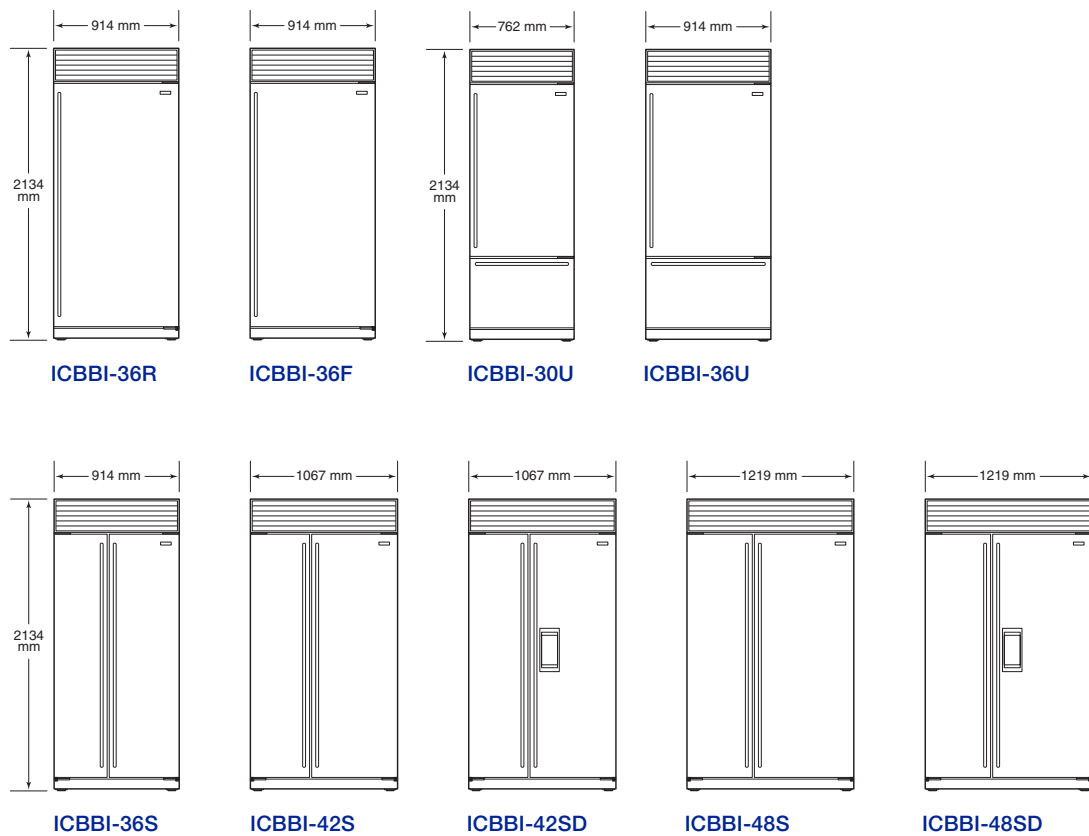

KEY FEATURES

- Three distinct design approaches: overlay, flush inset and stainless steel.
- Handle options coordinate with handles of Wolf cooking products.
- Dual refrigeration; two compressors preserve food's goodness in two sealed compartments.
- Energy efficient.
- Advanced air purification system.
- Crisper and deli drawers form a lower-temperature zone for produce and meats.
- Flip-up grille provides easy access for quick routine maintenance.
- All models are Star-K certified.

Built-In Models

SPECIFICATIONS

Interior Capacity	R (L)	F (L)
ALL REFRIGERATOR / ALL FREEZER MODELS		
ICBBI-36R	662	
ICBBI-36F		640
OVER-AND-UNDER MODELS		
ICBBI-30U	362	116
ICBBI-36U	451	149
SIDE-BY-SIDE MODELS		
ICBBI-36S	346	227
ICBBI-42S	455	227
ICBBI-42SD	453	230
ICBBI-48S	533	270
ICBBI-48SD	531	274

Shipping Weight	kg
ALL REFRIGERATOR / ALL FREEZER MODELS	
ICBBI-36R	191
ICBBI-36F	184
OVER-AND-UNDER MODELS	
ICBBI-30U	210
ICBBI-36U	234
SIDE-BY-SIDE MODELS	
ICBBI-36S	244
ICBBI-42S	264
ICBBI-42SD	276
ICBBI-48S	286
ICBBI-48SD	298

All Refrigerator / All Freezer Models

OVERALL DIMENSIONS

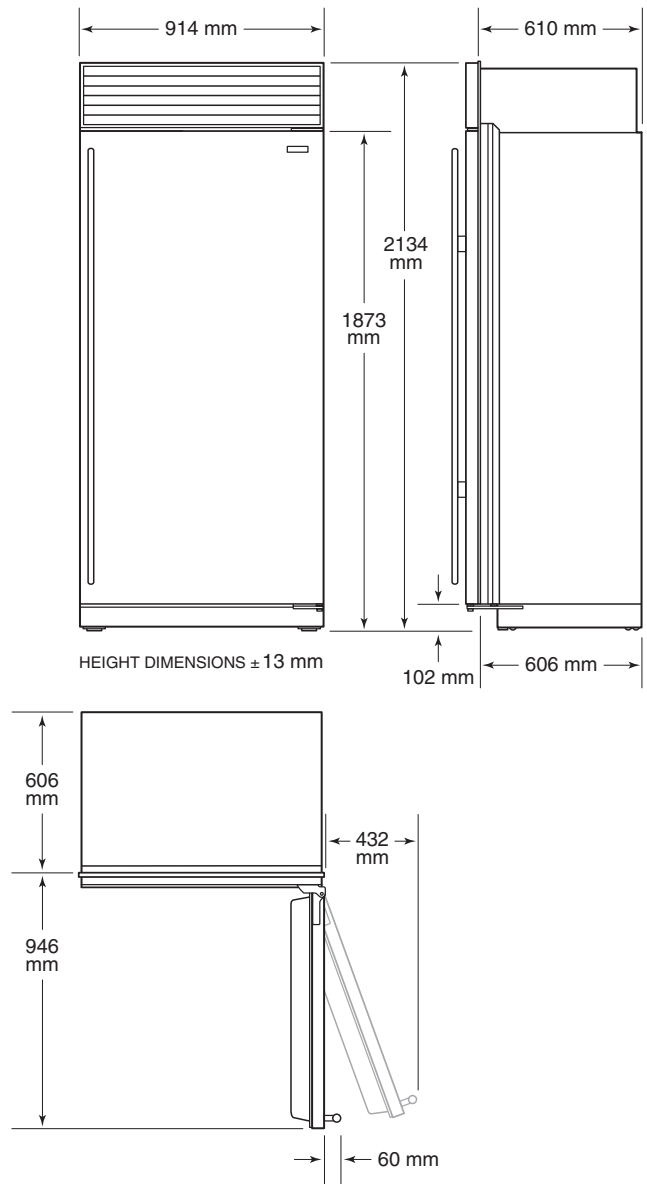

MODELS ICBBI-36R AND ICBBI-36F

Shipping weights and overall dimensions are based on stainless steel models. For flush inset applications, add 13 mm to door clearance dimensions.

Over-and-Under Models

OVERALL DIMENSIONS

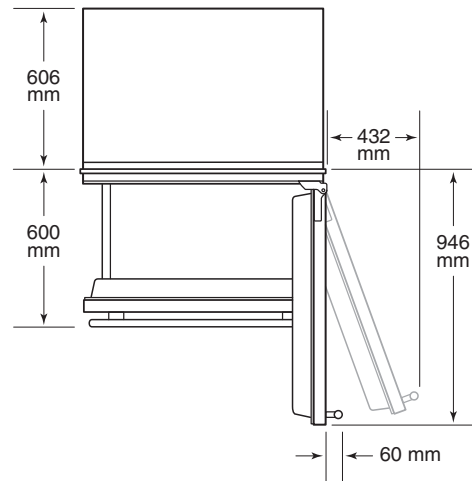
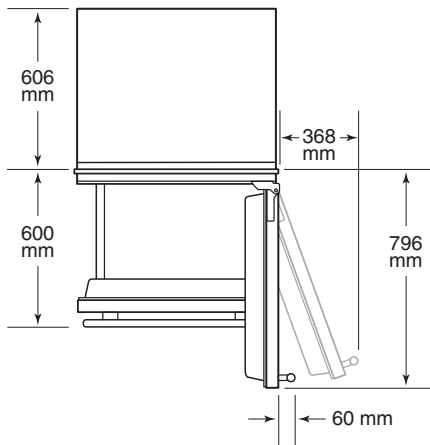
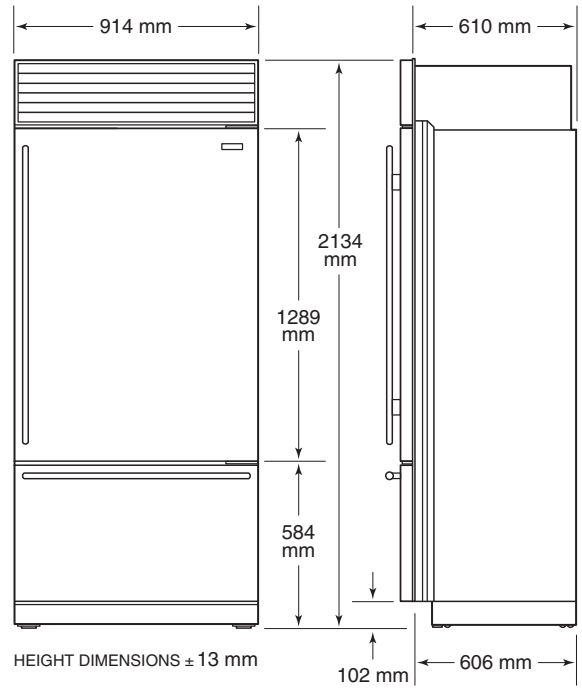
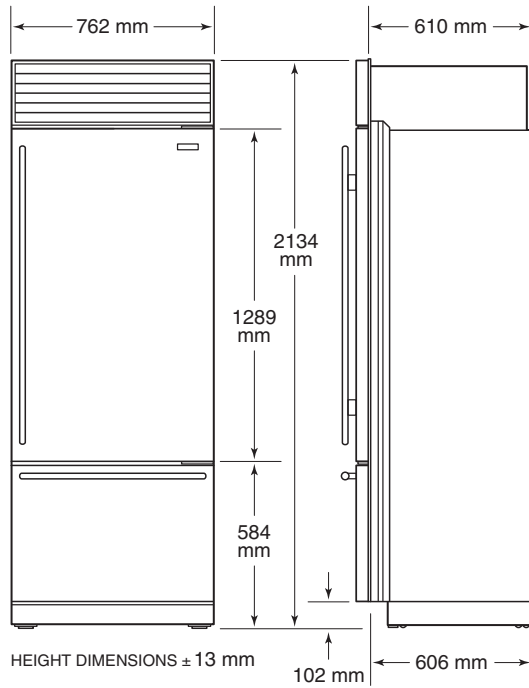

MODEL ICBBI-30U

MODEL ICBBI-36U

Side-by-Side Models

OVERALL DIMENSIONS

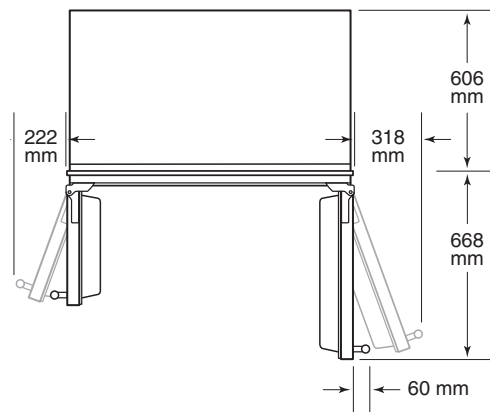
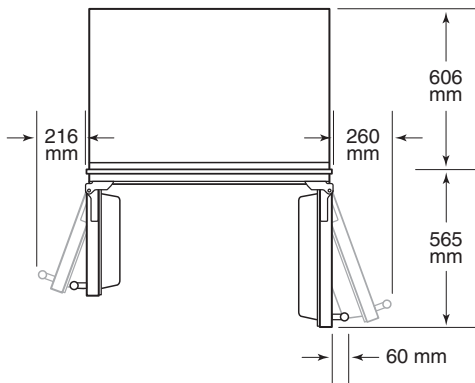
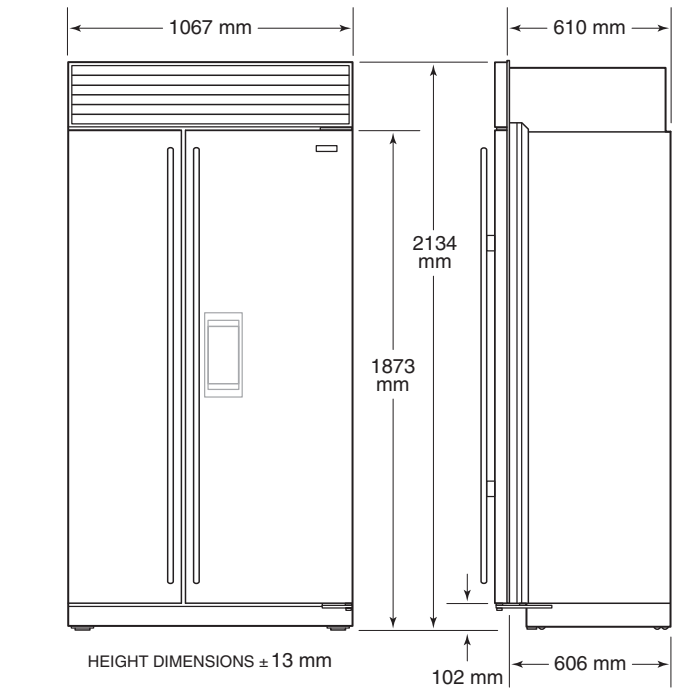
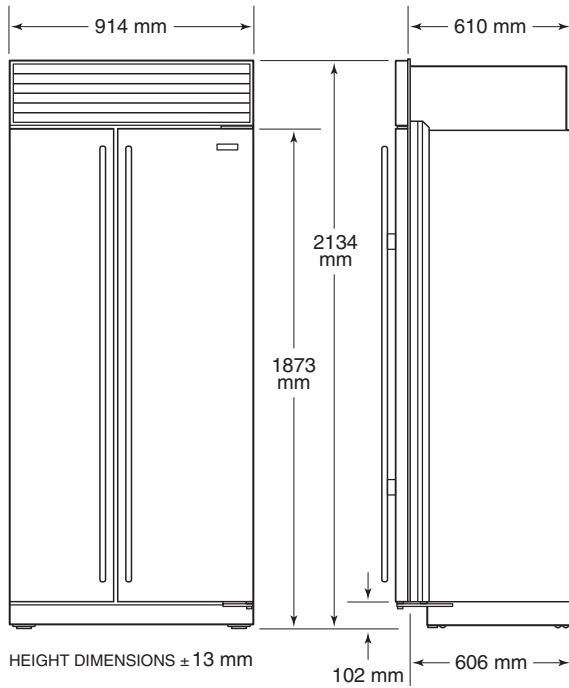

MODEL ICBBI-36S

MODELS ICBBI-42S AND ICBBI-42SD

Overall dimensions are based on stainless steel models.
For flush inset applications, add 13 mm to door clearance dimensions.

Side-by-Side Models

OVERALL DIMENSIONS

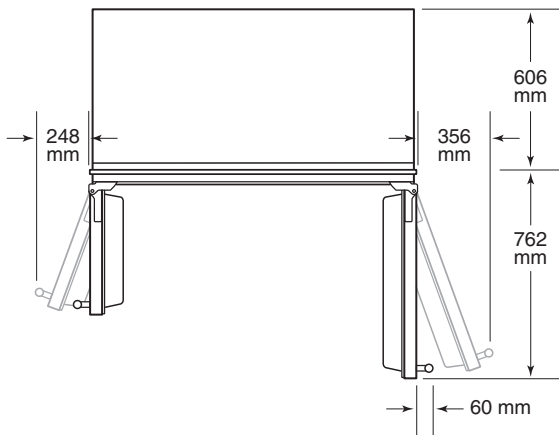
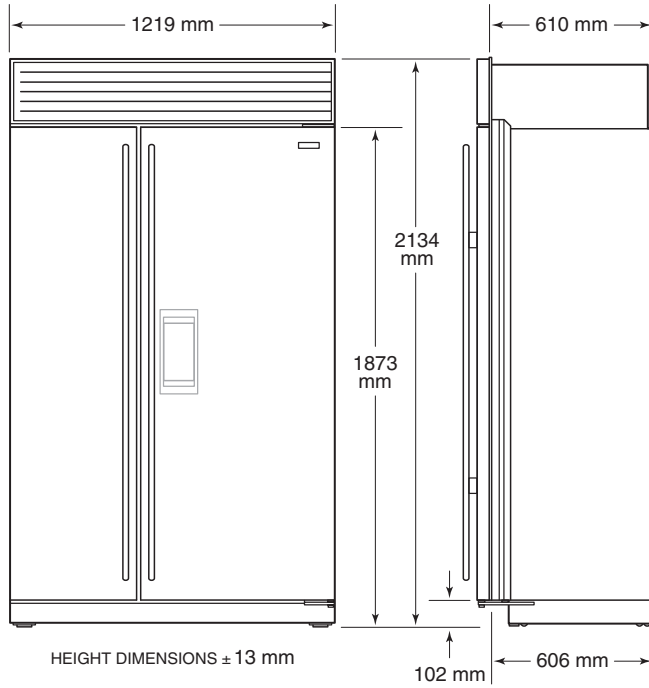

MODELS ICBB1-48S AND ICBB1-48SD

Built-In Models

STANDARD INSTALLATION

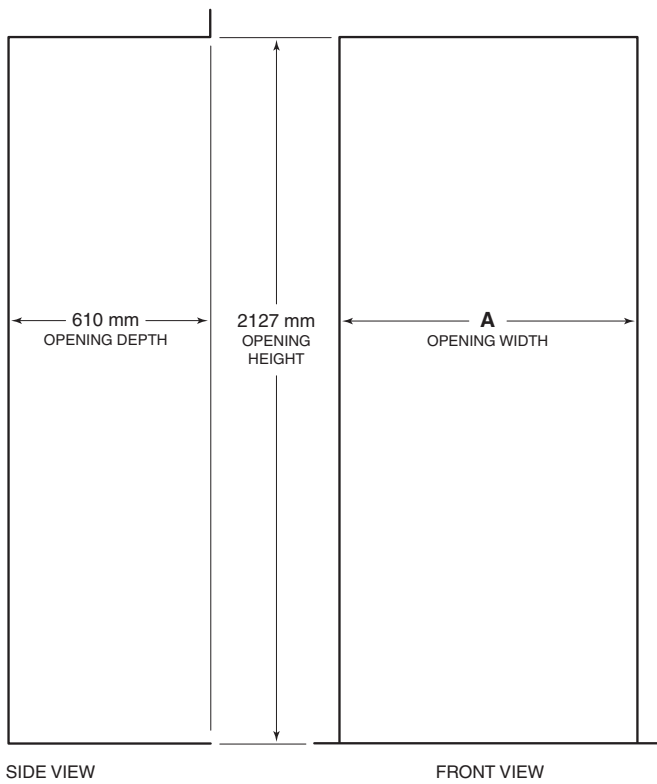
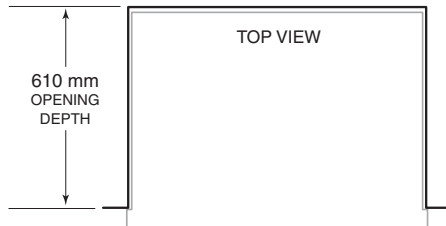

Opening Width	A
ICBBI-36R and ICBBI-36F	902 mm
ICBBI-30U	746 mm
ICBBI-36U	902 mm
ICBBI-36S	902 mm
ICBBI-42S and ICBBI-42SD	1054 mm
ICBBI-48S and ICBBI-48SD	1206 mm

IMPORTANT NOTE: If two units are installed side by side, refer to pages 21–22 for dual standard installations.

Stainless steel models are ready to install out of the box.

Planning Information

ELECTRICAL REQUIREMENTS

International models from the factory designed without a transformer require a 220-240 V AC, 50/60 Hz electrical supply, fused at the correct rating for the unit. If required by local or national codes, the power cord can be easily replaced using the power inlet device.

For all built-in models, the electrical supply should be located within the shaded area shown in the illustration. Follow local codes and ordinances when installing the receptacle. A separate circuit servicing only this appliance is required. A ground fault circuit interrupter (GFCI) is not recommended and may cause interruption of operation.

Electrical Requirements	
Power Supply	220-240 V AC, 50/60 Hz
Circuit Breaker	10 amp
Receptacle	3-prong grounding-type

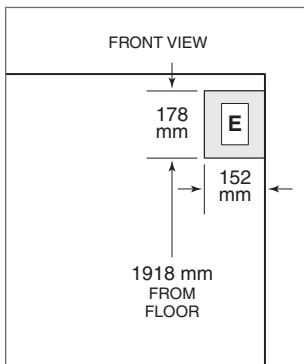

Location of electrical supply.

PLUMBING REQUIREMENTS

For built-in models with an automatic ice maker, the water supply line should be located within the shaded area shown in the illustrations. The water supply line should be connected to the house supply with an easily accessible shut-off valve between the supply and the unit. Do not use self-piercing valves. A saddle valve kit (4200880) is available through your authorized Sub-Zero dealer. The water line must not interfere with installation of the anti-tip brackets.

IMPORTANT NOTE: A reverse osmosis system can be used provided there is constant water pressure of 2.1 bar to 6.9 bar supplied to the unit at all times.

Plumbing Requirements	
Water Supply Line	6.35 mm OD copper line
Water Pressure	2.1–6.9 bar
Excess Water Line for Connection	914 mm

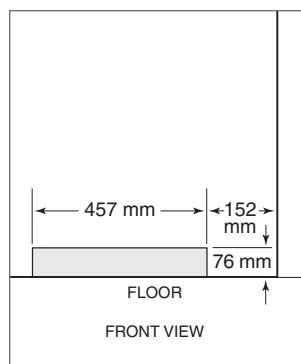

Location of water supply—rear.

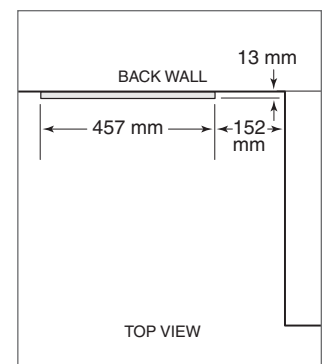

Location of water supply—bottom.

Overlay Panels

If you and your client have ordered an overlay model, you will be adding panels and handles to give the unit a more custom look. The overlay panel design option is available for all built-in overlay models. For exact door panel dimensions, refer to overlay panel specifications on the following pages.

IMPORTANT NOTE: Overlay models can be used in an overlay or a flush inset application. Be aware that the application specified will affect panel sizes, rough opening dimensions and installation.

The overlay design allows decorative panels to cover the door trim for a more seamless appearance that blends with the design of the room. The most common way to achieve this look is to work with three panels—the decorative overlay panel, which is typically 19 mm, a 3 mm spacer panel and a 6 mm backer panel. Depending on your cabinet manufacturer, this could also be one panel routed for different dimensions.

Regardless of the physical construction of the panels (three-panel assembly or routed panel), you will need to follow the overlay panel specifications on the following pages for exact sizing and panel placement to ensure a proper fit.

Overlay Panel Requirements	
MAX WEIGHT PER PANEL	
All Overlay Models	23 kg
Grille Panel	6 kg
MIN PANEL THICKNESS	
All Overlay Panels	16 mm

The illustrations provide a cross section view of the three-panel assembly, showing placement of the trim and a rear view of the three-panel assembly with critical dimensions, standard for all built-in models.

Overlay grille panels for the panel grille match the design of the overlay door panels. Dimensions for the grille panel are listed in the overlay panel specifications on the following pages.

IMPORTANT NOTE: When installing two units in a side-by-side application, refer to pages 21–22 for dual standard installations. Be aware that rough opening dimensions are different for this application.

⚠ CAUTION
 Do not exceed overlay panel dimensions, as this could cause damage to panels and the Sub-Zero unit.

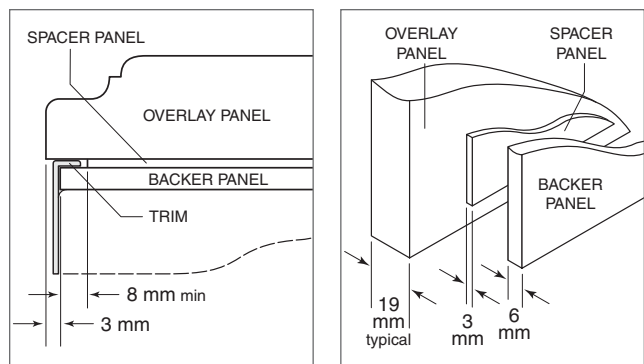

Panel assembly cross section. Panel assembly rear view.

Overlay Panels

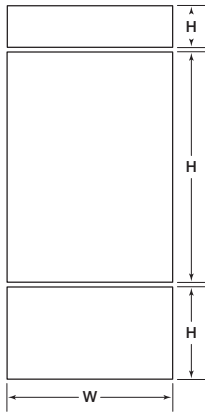

ICBBI-30U / ICBBI-36U

Model ICBBI-30U		
REFRIGERATOR	W	H
Overlay Panel	762 mm	1273 mm
Spacer Panel	740 mm	1253 mm
Backer Panel	756 mm	1268 mm
FREEZER	W	H
Overlay Panel	762 mm	483 mm
Spacer Panel	740 mm	459 mm
Backer Panel	756 mm	475 mm
GRILLE	W	H
Overlay Panel	762 mm	235 mm*
Spacer Panel	740 mm	211 mm
Backer Panel	756 mm	227 mm

Model ICBBI-36U		
REFRIGERATOR	W	H
Overlay Panel	914 mm	1273 mm
Spacer Panel	892 mm	1253 mm
Backer Panel	908 mm	1268 mm
FREEZER	W	H
Overlay Panel	914 mm	483 mm
Spacer Panel	892 mm	459 mm
Backer Panel	908 mm	475 mm
GRILLE	W	H
Overlay Panel	914 mm	235 mm*
Spacer Panel	892 mm	211 mm
Backer Panel	908 mm	227 mm

*Panel height may be increased by 13 mm to hide upper main frame. For more information, refer to the built-in panel configurator at subzero.com/trade/panels.

Grille panel dimensions listed are for a standard 2134 mm finished height. For a 2108 mm finished height, subtract 25 mm from grille panel height dimensions. For a 2235 mm finished height, add 102 mm to height dimensions. A 2108 mm or 2235 mm panel grille must be ordered to accept a 2108 mm or 2235 mm custom panel. Width dimensions do not vary.

Overlay Panels

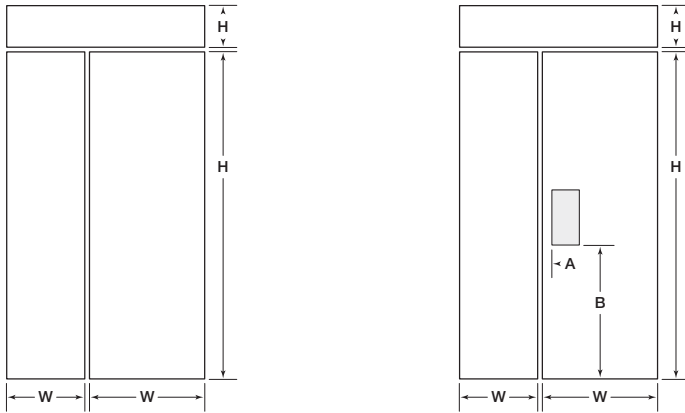

ICBBI-36S / ICBBI-42S / ICBBI-48S

ICBBI-48SD

Model ICBBI-36S		
	W	H
REFRIGERATOR		
Overlay Panel	510 mm	1772 mm
Spacer Panel	487 mm	1751 mm
Backer Panel	503 mm	1767 mm
FREEZER		
Overlay Panel	398 mm	1772 mm
Spacer Panel	376 mm	1751 mm
Backer Panel	392 mm	1767 mm
GRILLE		
Overlay Panel	914 mm	235 mm*
Spacer Panel	892 mm	211 mm
Backer Panel	908 mm	227 mm

Model ICBBI-42S		
	W	H
REFRIGERATOR		
Overlay Panel	637 mm	1772 mm
Spacer Panel	614 mm	1751 mm
Backer Panel	630 mm	1767 mm
FREEZER		
Overlay Panel	424 mm	1772 mm
Spacer Panel	402 mm	1751 mm
Backer Panel	418 mm	1767 mm
GRILLE		
Overlay Panel	1067 mm	235 mm*
Spacer Panel	1045 mm	211 mm
Backer Panel	1060 mm	227 mm

Models ICBBI-48S and ICBBI-48SD		
	W	H
REFRIGERATOR		
Overlay Panel	730 mm	1772 mm
Spacer Panel	708 mm	1751 mm
Backer Panel	724 mm	1767 mm
FREEZER		
Overlay Panel	483 mm	1772 mm
Spacer Panel	460 mm	1751 mm
Backer Panel	476 mm	1767 mm
GRILLE		
Overlay Panel	1219 mm	235 mm*
Spacer Panel	1197 mm	211 mm
Backer Panel	1213 mm	227 mm
ICBBI-48SD		
Dispenser Cut-Out	149 mm	316 mm
Cut-Out Location	A 51 mm	B 732 mm

*Panel height may be increased by 13 mm to hide upper main frame. For more information, refer to the built-in panel configurator at subzero.com/trade/panels.

Grille panel dimensions listed are for a standard 2134 mm finished height. For a 2108 mm finished height, subtract 25 mm from grille panel height dimensions. For a 2235 mm finished height, add 102 mm to height dimensions. A 2108 mm or 2235 mm panel grille must be ordered to accept a 2108 mm or 2235 mm custom panel. Width dimensions do not vary.

Flush Inset Application

It is necessary to consider the following points when planning for a flush inset application:

- The flush inset depth is 56 mm deeper than the standard opening.
- The flush inset width is 64 mm wider than the standard opening.
- The flush inset height is 6 mm higher than the standard opening.
- Panel widths increase to achieve the flush inset look.
- You must allow a 13 mm reveal around the perimeter of the unit and grille to allow for proper door swing and airflow.

IMPORTANT NOTE: The flush inset application is not a separate model. This is an overlay unit in a flush installation. The same model is used in an overlay or flush inset application.

Rough opening dimensions for the flush inset application assume the use of a 19 mm decorative panel. The illustrations at right show the difference between standard and flush inset installations.

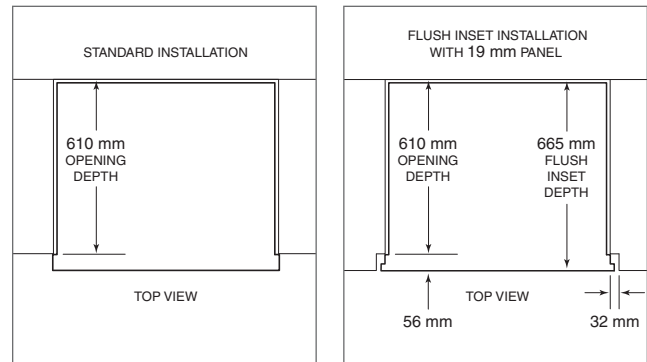

Standard installation.

Flush inset installation.

Built-In Models

FLUSH INSET INSTALLATION

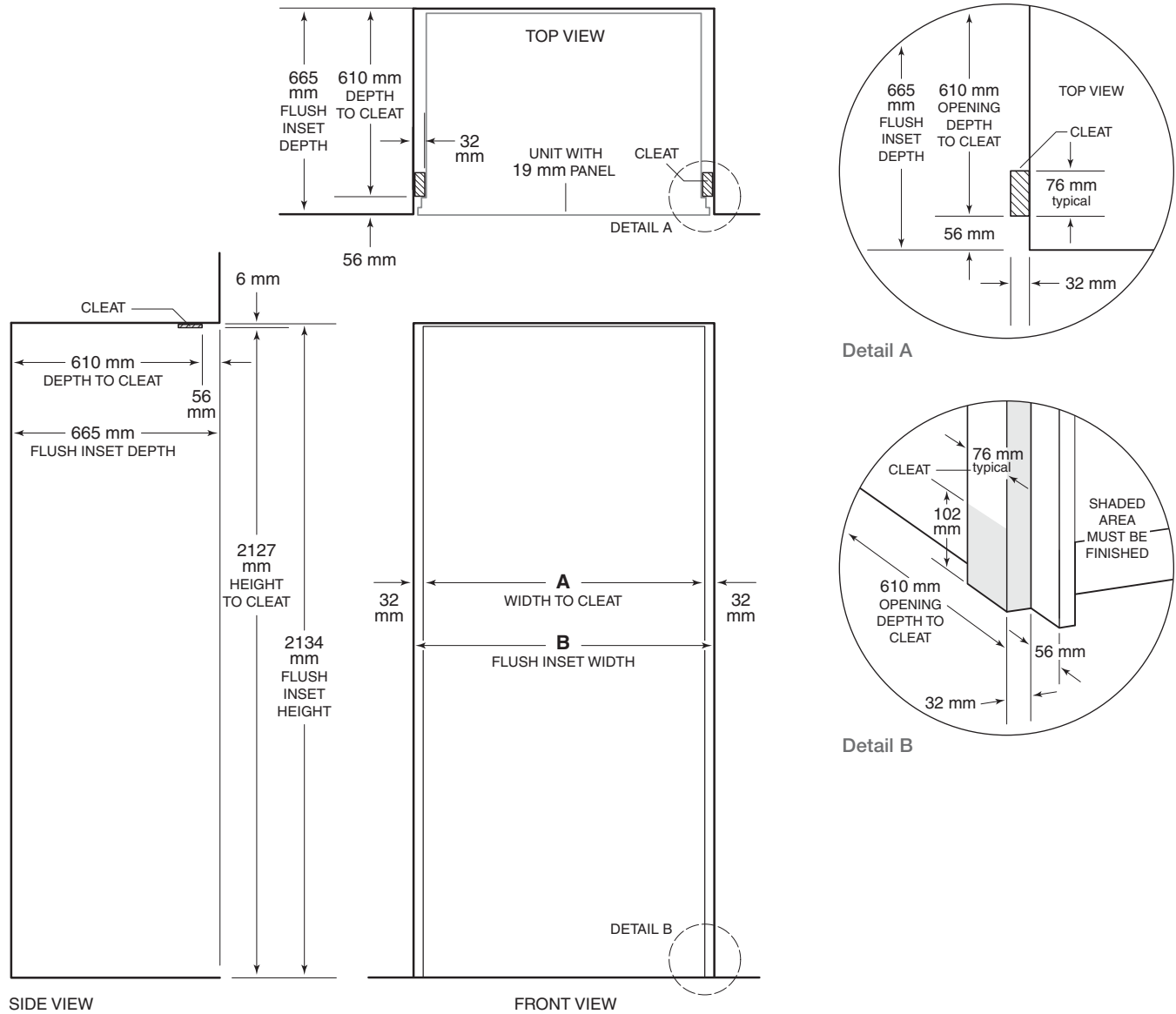

Flush Inset Opening Widths	A	B
ICBBI-30U	746 mm	813 mm
ICBBI-36U	902 mm	965 mm
ICBBI-36S	902 mm	965 mm
ICBBI-42S	1054 mm	1118 mm
ICBBI-48S and ICBBI-48SD	1206 mm	1270 mm

IMPORTANT NOTE: Dimensions assume a 19 mm panel thickness.

IMPORTANT NOTE: If two units are installed side by side, refer to pages 23–27 for dual flush inset installations.

Flush Inset Panels

The flush inset application allows decorative panels on the front of the unit to be flush with surrounding cabinetry and is available for all built-in overlay models. For exact panel dimensions, refer to flush inset panel specifications on the following pages.

The flush inset design allows decorative panels to cover the door trim for a seamless appearance that blends with the design of the room. The most common way to achieve this look is to work with three panels—the decorative flush inset panel, which is typically 19 mm, a 3 mm spacer panel and a 6 mm backer panel. Depending on your cabinet manufacturer, this could also be one panel routed for different dimensions.

Regardless of the physical construction of the panels (three-panel assembly or routed panel), you will need to follow the flush inset panel specifications on the following pages for exact sizing and panel placement to ensure a proper fit.

⚠ CAUTION

Do not exceed flush inset panel dimensions, as this could cause damage to panels and the Sub-Zero unit.

Flush Inset Panel Requirements	
MAX WEIGHT PER PANEL	
All Flush Inset Models	23 kg
Grille Panel	6 kg
MIN PANEL THICKNESS	
All Flush Inset Panels	16 mm

The illustration below provides a rear view of the three-panel assembly with critical dimensions, standard for all built-in models.

IMPORTANT NOTE: The inside edges of the rough opening as well as the sides and a portion of the back side of the decorative panels will need to be finished, as they will be exposed when the doors are open.

IMPORTANT NOTE: For flush inset panels thicker than 19 mm, a 90° door stop may be required to prevent interference with adjacent cabinets. Refer to the full-scale templates at the end of this section.

IMPORTANT NOTE: When installing two units side by side in a flush inset application, refer to pages 23–27 for dual flush inset installations. Be aware that rough opening dimensions, panel sizes and offsets are different for this application.

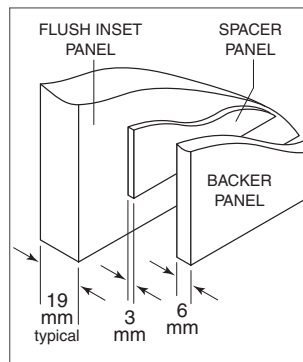

Three-panel assembly.

Flush Inset Panels

PANEL OFFSETS

Illustrations A–F provide panel offsets and reveals for all built-in models in a flush inset application. Refer to the chart below for reference to the illustrations relating to your specific model.

For additional information on model-specific panel reveals, visit the specification library section of our website, subzerotrade.com.

Panel Offsets	Illus.
OVER-AND-UNDER	
Door / Drawer / Grille Sides	A
Grille Top	C
Grille Bottom / Door Top	D
Door Bottom / Drawer Top	E
Drawer Bottom	F
SIDE-BY-SIDE	
Doors (hinge) / Grille Sides	A
Doors (handle) Sides	B
Grille Top	C
Grille Bottom / Door Top	D
Door Bottom	F

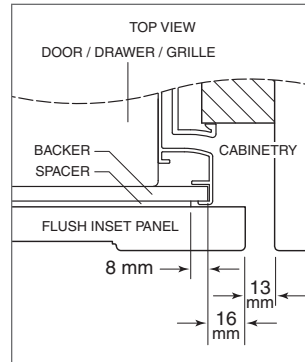

Illus. A

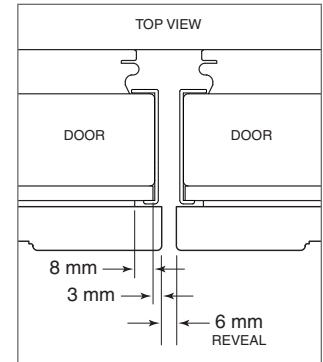

Illus. B

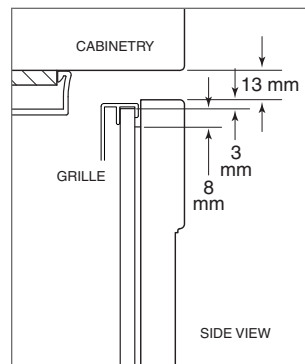

Illus. C

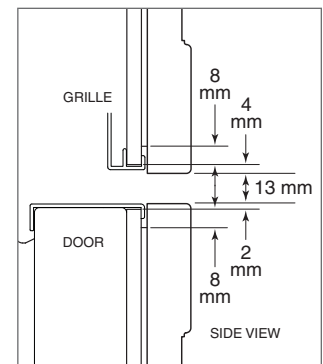

Illus. D

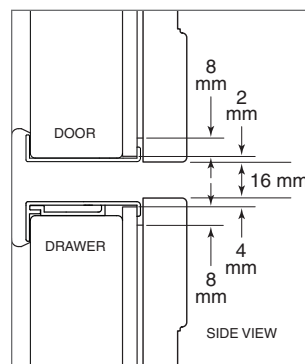

Illus. E

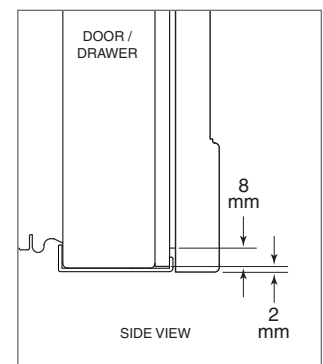

Illus. F

Flush Inset Panels

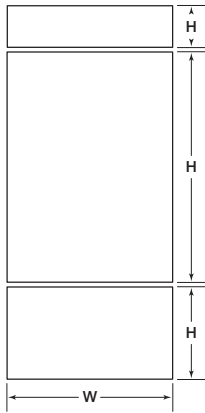

ICBBI-30U / ICBBI-36U

Model ICBBI-30U		
	W	H
REFRIGERATOR		
Flush Inset Panel	787 mm	1273 mm
Spacer Panel	740 mm	1253 mm
Backer Panel	756 mm	1268 mm
FREEZER		
Flush Inset Panel	787 mm	483 mm
Spacer Panel	740 mm	459 mm
Backer Panel	756 mm	475 mm
GRILLE		
Flush Inset Panel	787 mm	235 mm
Spacer Panel	740 mm	211 mm
Backer Panel	756 mm	227 mm

Model ICBBI-36U		
	W	H
REFRIGERATOR		
Flush Inset Panel	940 mm	1273 mm
Spacer Panel	892 mm	1253 mm
Backer Panel	908 mm	1268 mm
FREEZER		
Flush Inset Panel	940 mm	483 mm
Spacer Panel	892 mm	459 mm
Backer Panel	908 mm	475 mm
GRILLE		
Flush Inset Panel	940 mm	235 mm
Spacer Panel	892 mm	211 mm
Backer Panel	908 mm	227 mm

Grille panel dimensions listed are for a standard 2134 mm finished height. For a 2108 mm finished height, subtract 25 mm from grille panel height dimensions. For a 2235 mm finished height, add 102 mm to height dimensions. A 2108 mm or 2235 mm panel grille must be ordered to accept a 2108 mm or 2235 mm custom panel. Width dimensions do not vary.

Flush Inset Panels

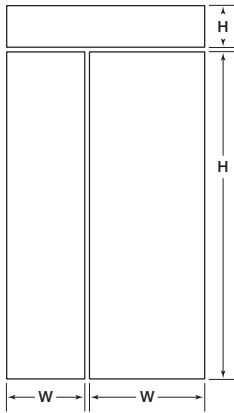

ICBBI-36S / ICBBI-42S / ICBBI-48S

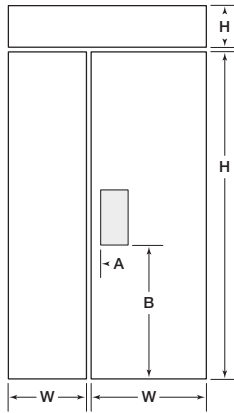

ICBBI-48SD

Model ICBBI-36S		
REFRIGERATOR	W	H
Flush Inset Panel	522 mm	1772 mm
Spacer Panel	487 mm	1751 mm
Backer Panel	503 mm	1767 mm
FREEZER	W	H
Flush Inset Panel	411 mm	1772 mm
Spacer Panel	376 mm	1751 mm
Backer Panel	392 mm	1767 mm
GRILLE	W	H
Flush Inset Panel	940 mm	235 mm
Spacer Panel	892 mm	211 mm
Backer Panel	908 mm	227 mm

Model ICBBI-42S		
REFRIGERATOR	W	H
Flush Inset Panel	649 mm	1772 mm
Spacer Panel	614 mm	1751 mm
Backer Panel	630 mm	1767 mm
FREEZER	W	H
Flush Inset Panel	437 mm	1772 mm
Spacer Panel	402 mm	1751 mm
Backer Panel	418 mm	1767 mm
GRILLE	W	H
Flush Inset Panel	1092 mm	235 mm
Spacer Panel	1045 mm	211 mm
Backer Panel	1060 mm	227 mm

Models ICBBI-48S and ICBBI-48SD		
REFRIGERATOR	W	H
Flush Inset Panel	743 mm	1772 mm
Spacer Panel	708 mm	1751 mm
Backer Panel	724 mm	1767 mm
FREEZER	W	H
Flush Inset Panel	495 mm	1772 mm
Spacer Panel	460 mm	1751 mm
Backer Panel	476 mm	1767 mm
GRILLE	W	H
Flush Inset Panel	1245 mm	235 mm
Spacer Panel	1197 mm	211 mm
Backer Panel	1213 mm	227 mm
DISPENSER (ICBBI-48SD)	W	H
Cut-Out	149 mm	316 mm
	A	B
Cut-Out Location	51 mm	732 mm

Grille panel dimensions listed are for a standard 2134 mm finished height. For a 2108 mm finished height, subtract 25 mm from grille panel height dimensions. For a 2235 mm finished height, add 102 mm to height dimensions. A 2108 mm or 2235 mm panel grille must be ordered to accept a 2108 mm or 2235 mm custom panel. Width dimensions do not vary.

Dispenser

MODEL ICBBI-48SD

The refrigerator door panel must include a cut-out to accommodate the dispenser glasswell and bezel. The thickness of the panel in this area can range from 6 mm to a maximum of 29 mm.

IMPORTANT NOTE: Regardless of the thickness of the panel for model ICBBI-48SD, you must plan for a flat landing area for the decorative bezel surrounding the glasswell area. The illustration to the right provides exact bezel dimensions. Refer to the appropriate panel specifications page for exact cut-out location. This landing area can be accomplished in a number of different ways.

One option (flush) is to rout the panel so the bezel will be flush with rails and stiles. You must rout a space to accommodate the height and width of the bezel. The width of the stile immediately to the left of the bezel must be 44 mm. Do not cut the entire stile to this dimension.

The other option (proud) shows a boxed out landing area for the bezel using stiles and rails to create this space. In this application, the bezel will sit proud of the stiles and rails. The total thickness of the panels at this level must not exceed 29 mm.

For overlay and flush inset models, mounting placement of the refrigerator door handle must assure proper access to the glasswell and adequate clearance under the handle.

The handle placement illustration shows the relation of the refrigerator door handle to the glasswell bezel on stainless steel models.

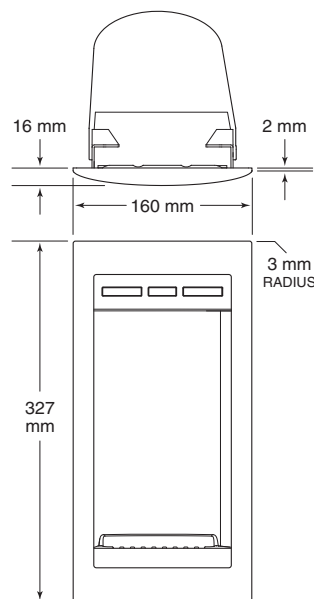

Dispenser dimensions.

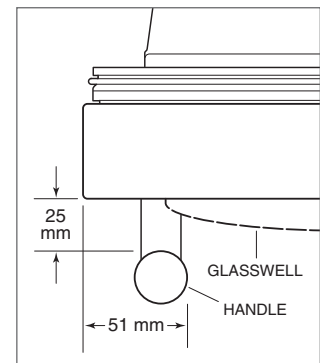

Handle placement.

Side Panels

Side panels can be used with every design application. When planning for side panels with the installation of a built-in model, you need to be aware of the space configuration to achieve a pleasing fit. Depending on the exact panel you are using with your unit, the height of the panel may vary.

IMPORTANT NOTE: The use of side panels may change the width of your rough opening.

The side panel will need to be a minimum of 610 mm deep and 13 mm thick. Refer to the illustrations below for side panel dimensions. Routing will be necessary so that the side panel fits flush against the side of the unit.

IMPORTANT NOTE: If you have a model ICBBI-30U or ICBBI-36U, extra routing will be necessary to prevent the panel from hitting the refrigerator lower hinge plate.

When installing a built-in unit with a custom side panel, an accessory kit (7003407) is required. Stainless steel and white enamel side panels are also available through your authorized Sub-Zero dealer.

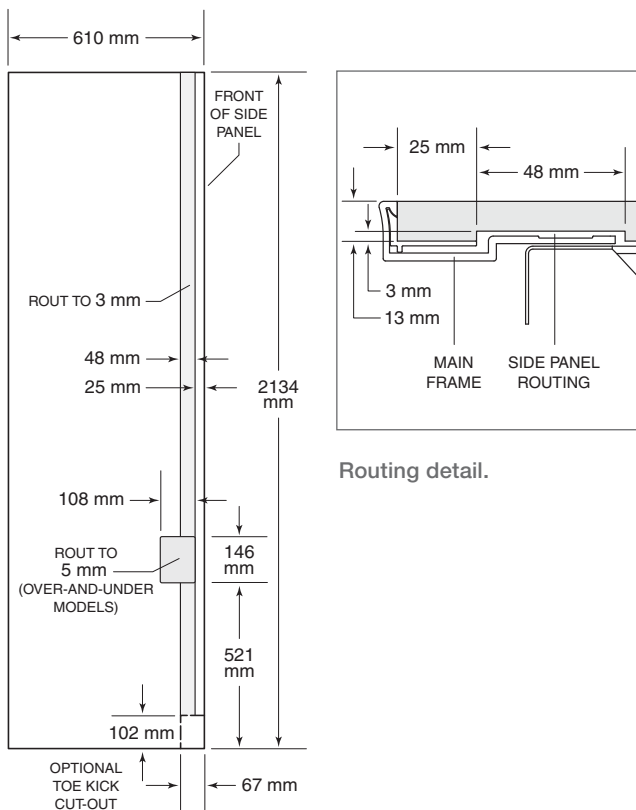

Side panel dimensions.

Dual Installation

STANDARD APPLICATION

Two overlay or stainless steel units may be placed side by side in a dual installation. Some standard applications will require a dual installation kit, available through your authorized Sub-Zero dealer. If you are installing two units side by side in a flush inset application, refer to page 23.

A custom filler strip can be used between two units in an overlay or stainless steel design application. It is recommended that the filler strip be at least 51 mm wide to prevent condensation between the units. Be sure to add the filler strip width to your rough opening width. Refer to the full-scale template on page 32.

Dual installations without a filler strip can only be accomplished using two units with opposite hinges as shown in illustration A below. The dual installations shown in illustrations B and C require a filler strip.

IMPORTANT NOTE: For the application shown in illustration A, a dual installation accessory kit is required. Refer to page 27 for information on dual installation kits.

Dual Installation Panel Requirements	
MAX WEIGHT PER PANEL	
All Models	23 kg
Dual Wide Grille Panel	12 kg
MIN PANEL THICKNESS	
Overlay and Flush Inset Panels	16 mm

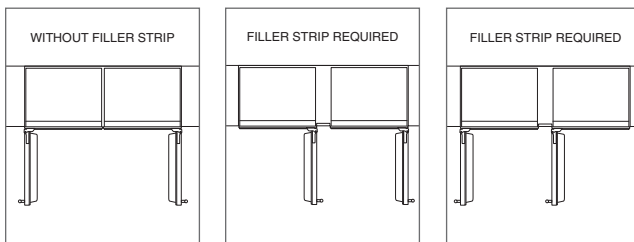

Illus. A

Illus. B

Illus. C

Dual Installation

STANDARD INSTALLATION

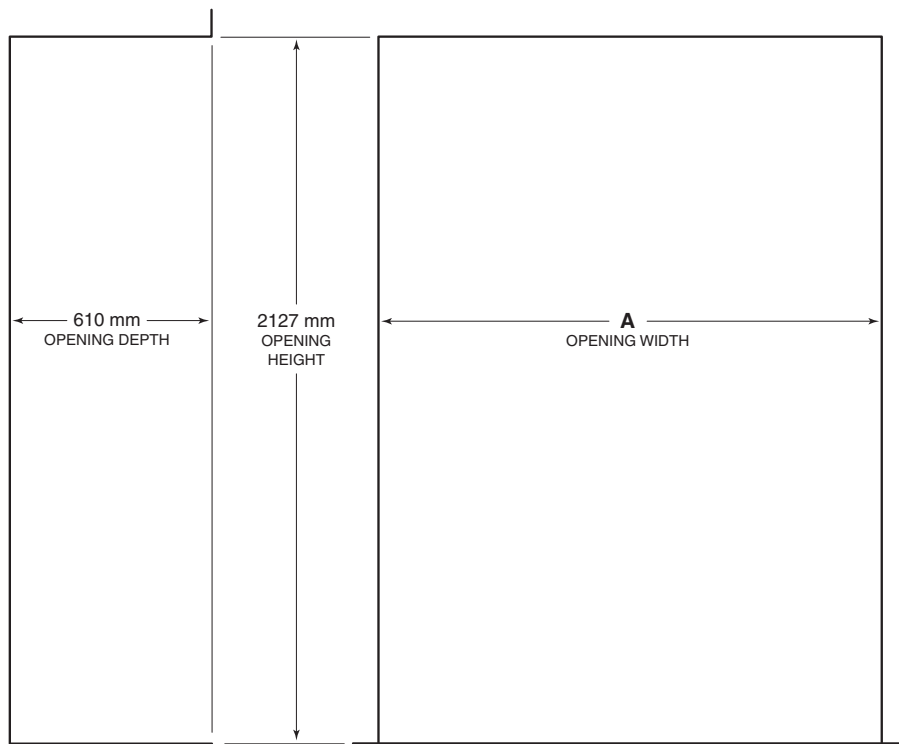
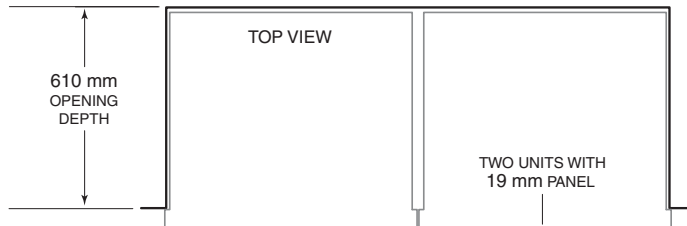

SIDE VIEW

FRONT VIEW

Opening Widths	A
Two 762 mm Models	1518 mm
762 mm and 914 mm Models	1670 mm
Two 914 mm Models	1822 mm

IMPORTANT NOTE: A dual installation kit will be required for this installation.

Stainless steel models are ready to install out of the box.

Dual Installation

FLUSH INSET APPLICATION

Installing two built-in models side by side in a flush inset application will require adjustments to the dimensions of your finished rough opening, panel sizes and panel offsets. It will also require a dual installation kit, available through your authorized Sub-Zero dealer.

Dual installations without a filler strip can only be accomplished using two units with opposite hinges as shown in illustration A below. The dual installations shown in illustrations B and C require a filler strip. Refer to the full-scale template on page 33. Illustration A is the only application that will accommodate the dual wide grille.

IMPORTANT NOTE: The application shown in illustration A can only be achieved by installing dual flush inset panels. Failure to install dual flush inset panels will cause the handle side of the panels to collide when closing. In this application a dual installation accessory kit is also required.

Dual flush inset panels and dual installation kits are available through your authorized Sub-Zero dealer. Refer to pages 25–26 for dual flush inset panel specifications and page 27 for information on dual installation kits.

Dual Installation Panel Requirements	
MAX WEIGHT PER PANEL	
All Models	23 kg
Dual Wide Grille Panel	12 kg
MIN PANEL THICKNESS	
Flush Inset Panels	16 mm

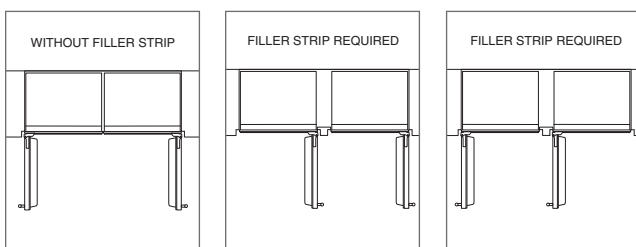

Illus. A

Illus. B

Illus. C

Dual Installation

FLUSH INSET INSTALLATION

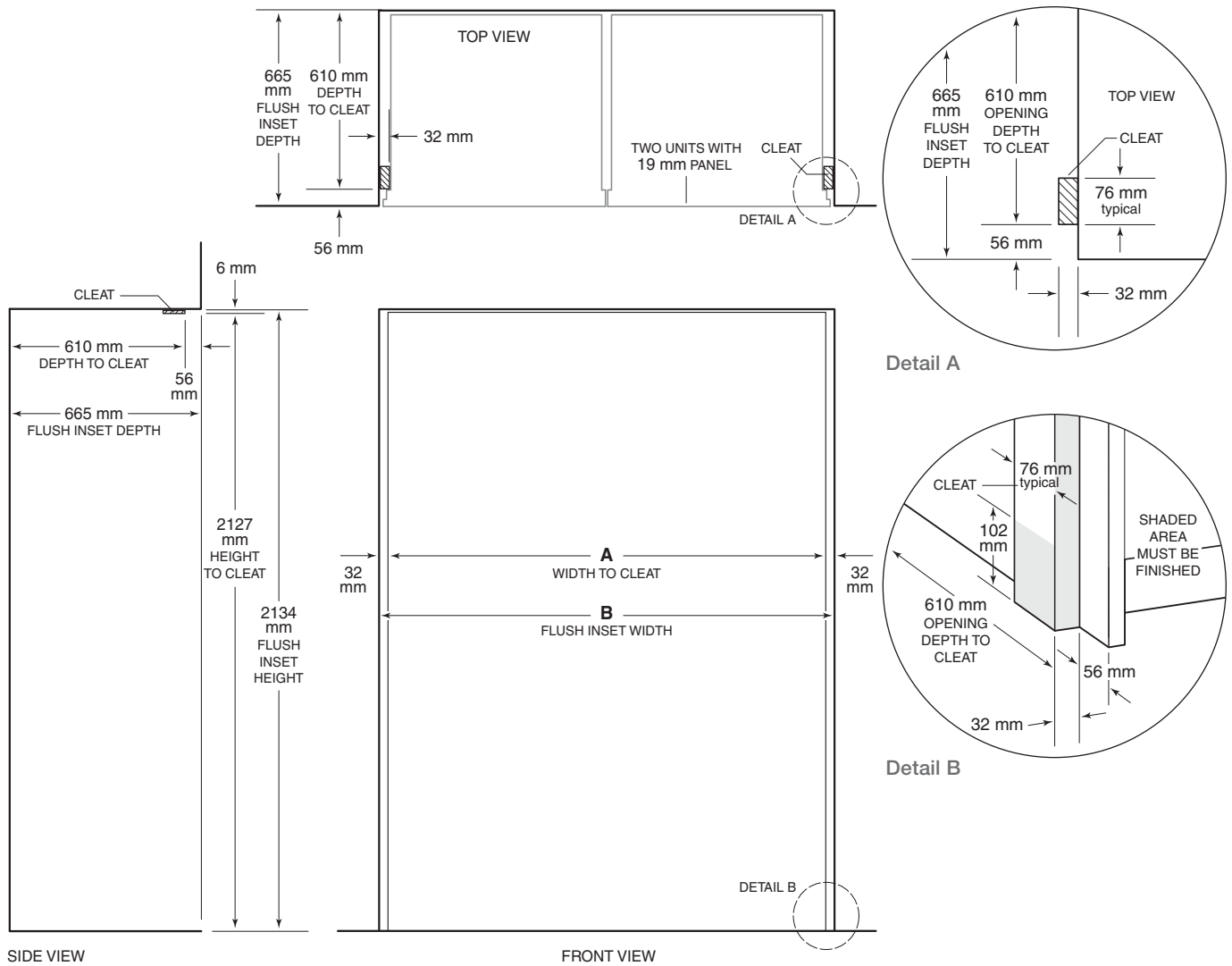

Opening Widths	A	B
Two 762 mm Models	1518 mm	1581 mm
762 mm and 914 mm Models	1670 mm	1734 mm
Two 914 mm Models	1822 mm	1886 mm

IMPORTANT NOTE: Dimensions assume a 19 mm panel thickness. A dual installation kit will be required for this installation.

Dual Installation

FLUSH INSET PANEL OFFSETS

When installing two built-in models side by side in a flush inset application, you must decrease the width of the decorative flush inset panels by 13 mm. Adjustments to the panel offsets will also need to be made. These adjustments are needed to achieve a proper fit and to ensure the panels do not collide when closing. Panel dimensions in the chart below have been adjusted to reflect the decrease in panel dimensions.

IMPORTANT NOTE: If a filler strip is not used, dual installations can only be accomplished using two units with opposite hinges.

Illustrations A–F provide panel offsets and reveals for all built-in models in a flush inset application. Refer to the chart below for reference to the illustrations relating to your specific model. All reveals are 13 mm unless otherwise specified.

For additional information on model-specific panel reveals, visit the specification library section of our website, subzerotrade.com.

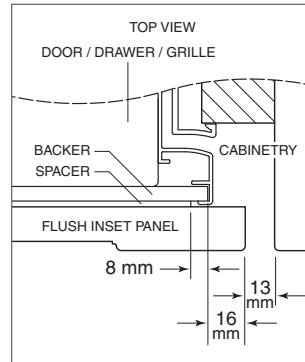

Illus. A

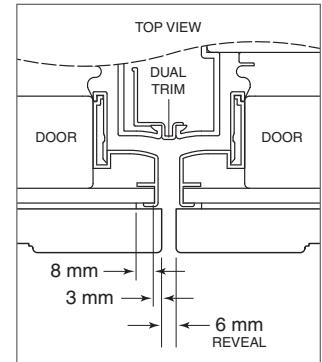

Illus. B

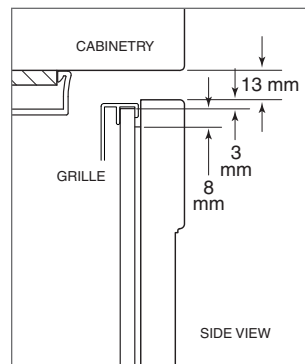

Illus. C

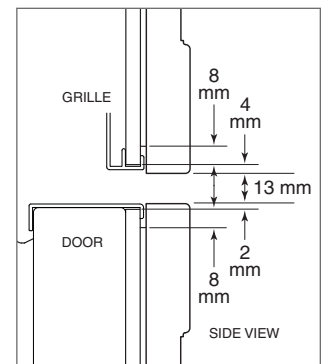

Illus. D

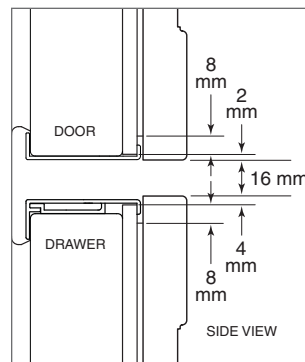

Illus. E

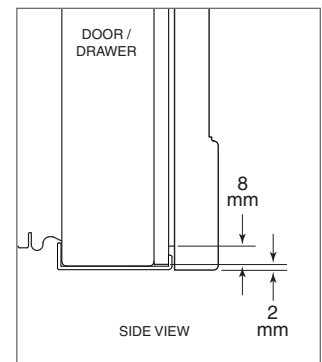

Illus. F

Panel Offsets	Illus.
OVER-AND-UNDER	
Doors (hinge) / Drawer / Grille Sides	A
Doors (handle) Sides	B
Grille Top	C
Grille Bottom / Door Top	D
Door Bottom / Drawer Top	E
Drawer Bottom	F

⚠ CAUTION
Do not exceed flush inset panel dimensions, as this could cause damage to panels and the Sub-Zero unit.

Dual Installation—Flush Inset Panels

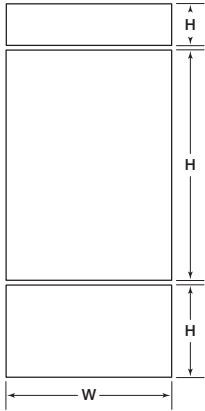

ICBBI-30U / ICBBI-36U

ICBBI-30U		
REFRIGERATOR	W	H
Flush Inset Panel	775 mm	1273 mm
Spacer Panel	740 mm	1253 mm
Backer Panel	756 mm	1268 mm
FREEZER	W	H
Flush Inset Panel	775 mm	483 mm
Spacer Panel	740 mm	459 mm
Backer Panel	756 mm	475 mm
GRILLE	W	H
Flush Inset Panel	775 mm	235 mm
Spacer Panel	740 mm	211 mm
Backer Panel	756 mm	227 mm

ICBBI-36U		
REFRIGERATOR	W	H
Flush Inset Panel	927 mm	1273 mm
Spacer Panel	892 mm	1253 mm
Backer Panel	908 mm	1268 mm
FREEZER	W	H
Flush Inset Panel	927 mm	483 mm
Spacer Panel	892 mm	459 mm
Backer Panel	908 mm	475 mm
GRILLE	W	H
Flush Inset Panel	927 mm	235 mm
Spacer Panel	892 mm	211 mm
Backer Panel	908 mm	227 mm

Grille panel dimensions listed are for a standard 2134 mm finished height. For a 2108 mm finished height, subtract 25 mm from grille panel height dimensions. For a 2235 mm finished height, add 102 mm to height dimensions. Width dimensions do not vary.

For dual wide grilles, refer to page 27.

Dual Installation Kit

INSTALLATION WITH DUAL WIDE GRILLE

This kit will replace the existing grilles that ship with the units and span the entire width of both units. The kit includes a 6 mm center trim strip (required for proper installation of the dual wide grille), heater, dual kickplate and mounting hardware. Dual wide grilles are available for all built-in models and design applications. The overlay dual installation kit with grille will accept overlay and dual flush inset panels. For dual wide grille panel dimensions, refer to the panel specifications below for your design application. Grille panel dimensions listed are for a standard 2134 mm finished height.

Dual Wide Grille—Overlay		
TWO 762 mm MODELS	W	H
Overlay Panel	1530 mm	235 mm
Spacer Panel	1508 mm	211 mm
Backer Panel	1524 mm	227 mm
762 mm AND 914 mm MODELS	W	H
Overlay Panel	1683 mm	235 mm
Spacer Panel	1661 mm	211 mm
Backer Panel	1676 mm	227 mm
TWO 914 mm MODELS	W	H
Overlay Panel	1835 mm	235 mm
Spacer Panel	1813 mm	211 mm
Backer Panel	1829 mm	227 mm

Dual Wide Grille—Flush Inset		
TWO 762 mm MODELS	W	H
Flush Inset Panel	1556 mm	235 mm
Spacer Panel	1508 mm	211 mm
Backer Panel	1524 mm	227 mm
762 mm AND 914 mm MODELS	W	H
Flush Inset Panel	1708 mm	235 mm
Spacer Panel	1661 mm	211 mm
Backer Panel	1676 mm	227 mm
TWO 914 mm MODELS	W	H
Flush Inset Panel	1861 mm	235 mm
Spacer Panel	1813 mm	211 mm
Backer Panel	1829 mm	227 mm

INSTALLATION WITH INDIVIDUAL GRILLES

This kit is available for those who choose to utilize the individual grilles that ship with each unit. The kit includes a 6 mm filler strip (which fills the reveal between the units and grilles), heater and mounting hardware. This dual installation kit is not required if a custom filler strip is used. The filler strip should be a minimum of 51 mm wide. Refer to the full-scale template on page 32 for more information.

Accessories

These optional accessories are available through your authorized Sub-Zero dealer. For local dealer information, visit the find a showroom section of our website, subzero.com.

- Flush inset front panels in stainless steel with handle options.
- Side panels in stainless steel and white enamel.
- Grilles for a 2108 mm or 2235 mm finished height.
- Tubular and pro handles to match the style of Wolf ovens and ranges.
- Dual installation kits with and without dual wide grille.
- Retrofit kits for use with 600 series panels.

STANDARD HANDLE LENGTHS

Refer to the chart below for standard lengths of tubular, and pro handles used on built-in models.

Standard Handle Lengths		
ALL REFRIGERATOR / ALL FREEZER AND SIDE-BY-SIDE		DOOR
Tubular Handle		1622 mm
Pro Handle		1146 mm
Stud Spacing		1114 mm
ICBBI-30U	DOOR	DRAWER
Tubular Handle	1124 mm	633 mm
Pro Handle	952 mm	533 mm
Stud Spacing	921 mm	414 mm
ICBBI-36U	DOOR	DRAWER
Tubular Handle	1124 mm	770 mm
Pro Handle	952 mm	597 mm
Stud Spacing	921 mm	567 mm

Overlay Panel Thickness

FULL-SCALE TEMPLATE

Overlay and flush inset panels must be a minimum of 16 mm thick to support mounting the handle. Panel thickness does not include backer and spacer panel. Mount handle close to the opening edge of the door.

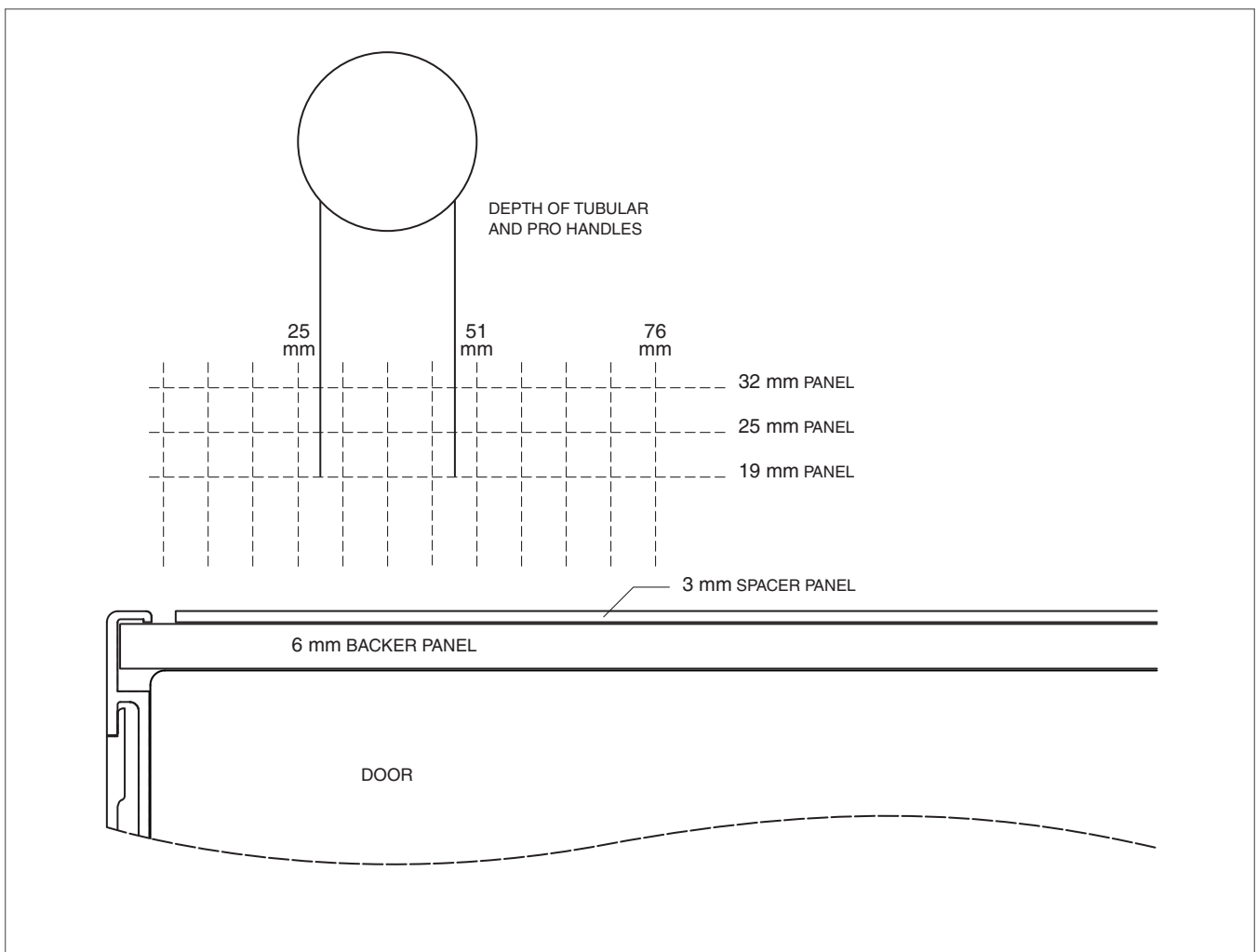

PANEL THICKNESS

OVERLAY AND FLUSH INSET APPLICATIONS

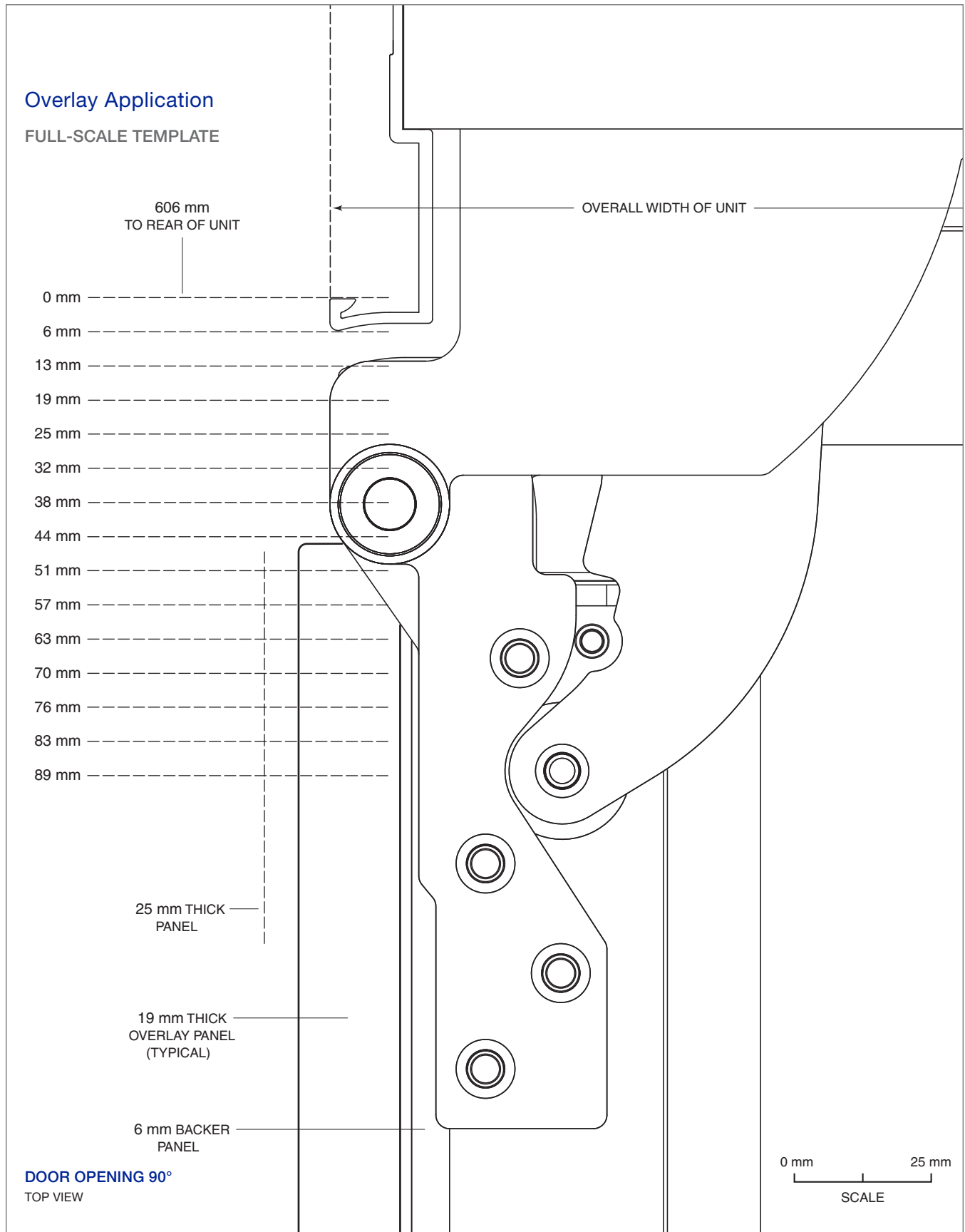

Flush Inset Application

FULL-SCALE TEMPLATE

For panels thicker than 19 mm, a 90° door stop may be required to prevent interference with adjacent cabinets.

610 mm
TO BACK WALL

32 mm

56 mm
ASSUMES
19 mm
FLUSH INSET
PANEL
THICKNESS

25 mm THICK
PANEL

19 mm THICK
FLUSH INSET PANEL
(TYPICAL)

6 mm BACKER
PANEL

DOOR OPENING 110°
TOP VIEW

0 mm 25 mm
SCALE

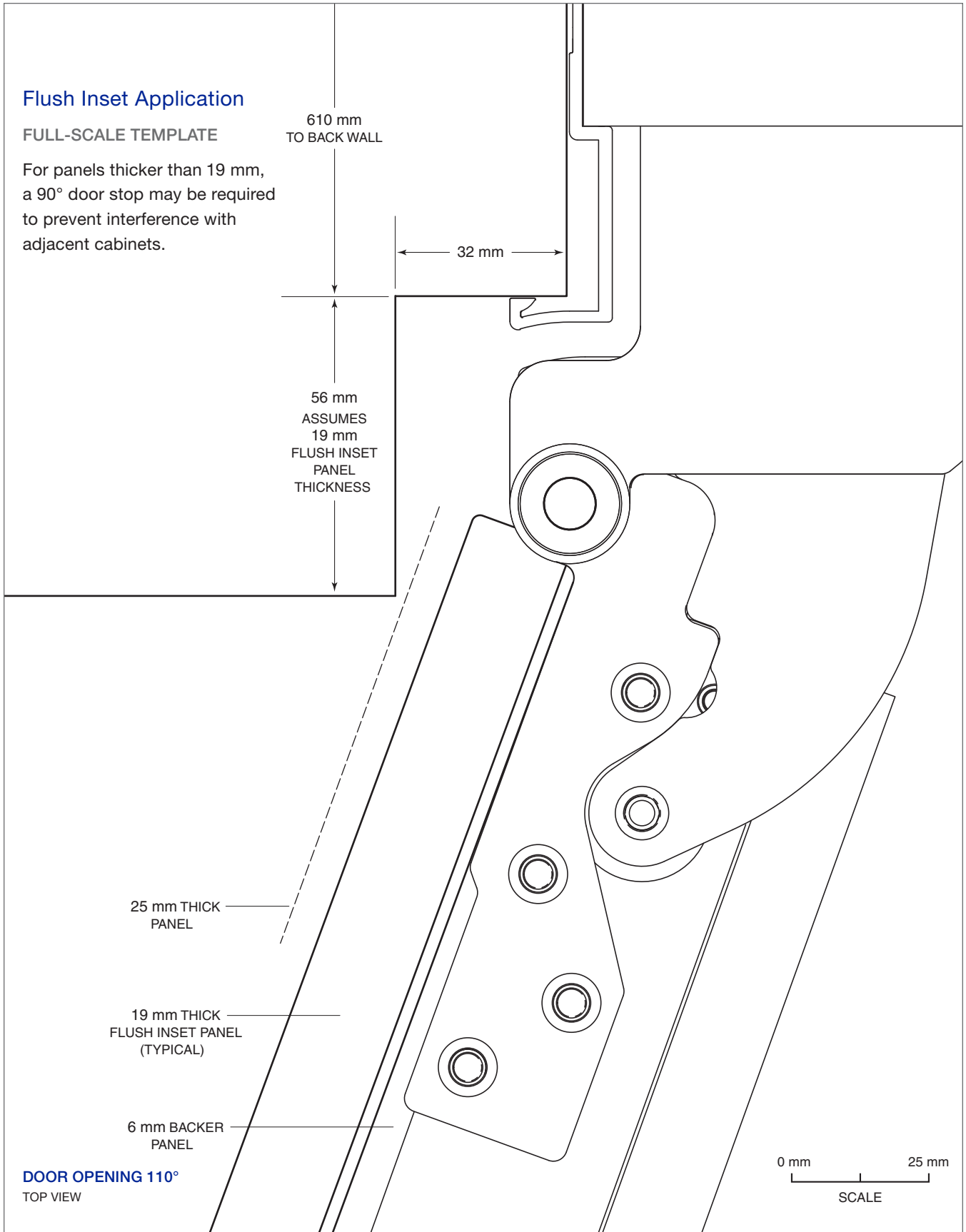

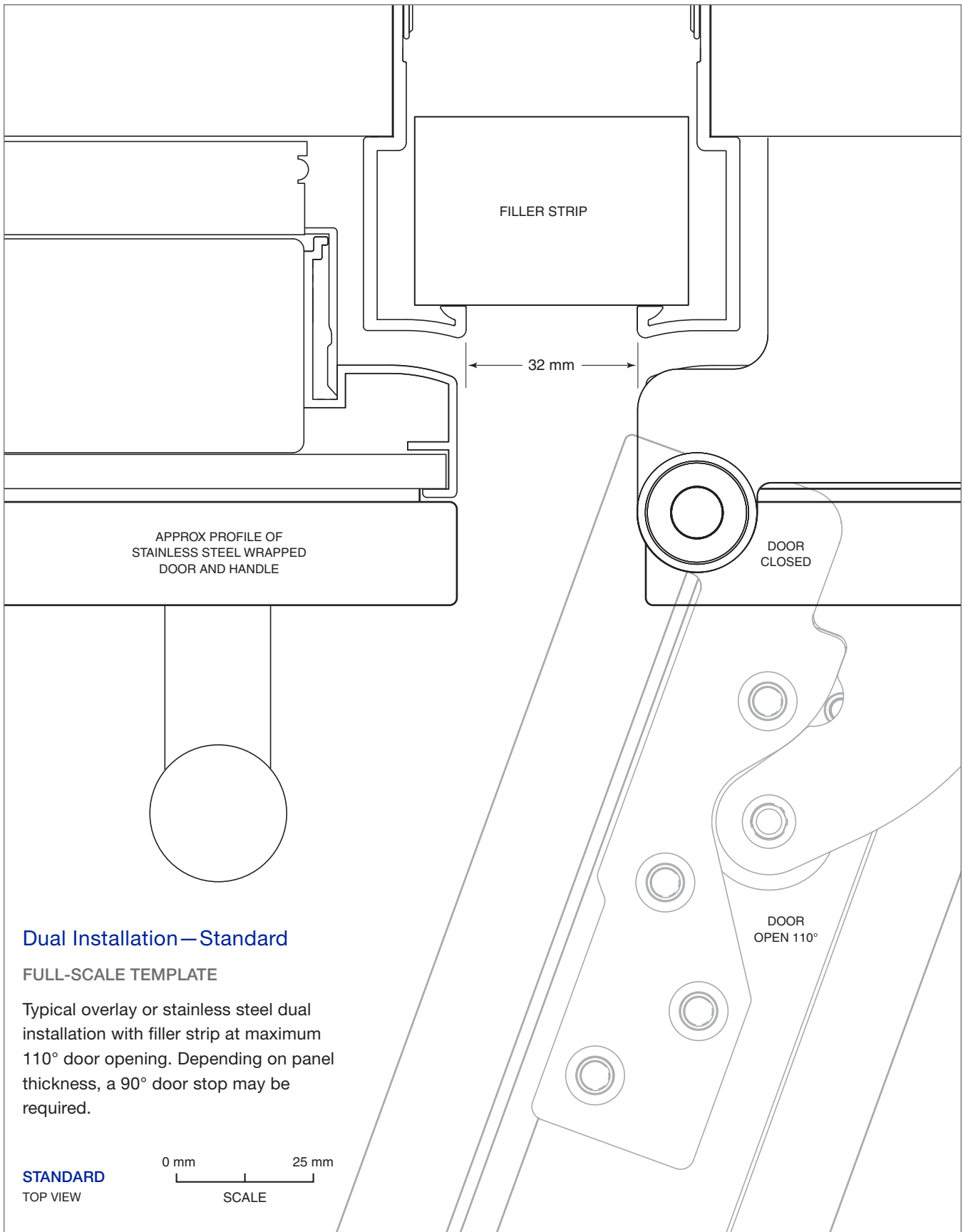

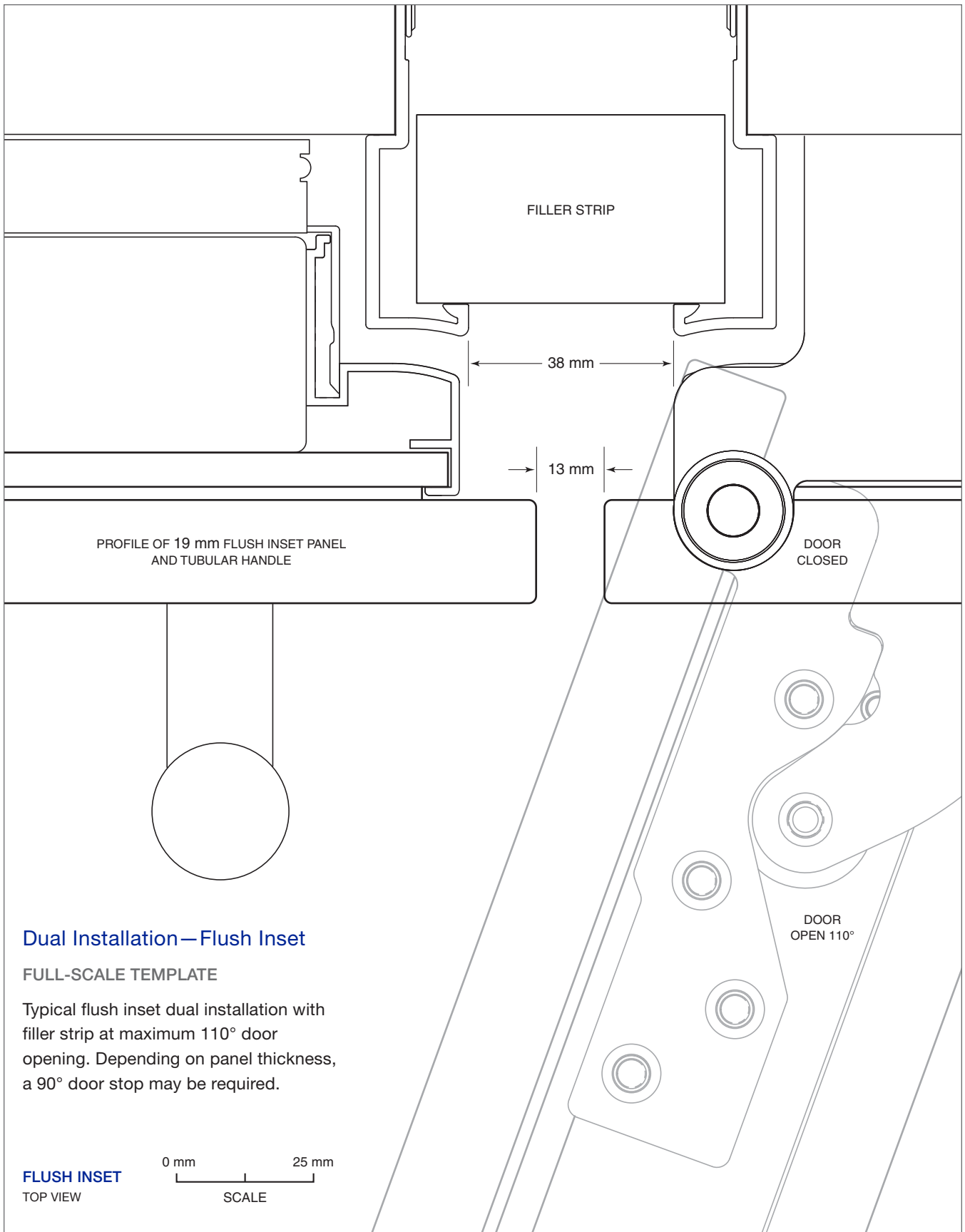

Dual Installation—Flush Inset

FULL-SCALE TEMPLATE

Typical flush inset dual installation with filler strip at maximum 110° door opening. Depending on panel thickness, a 90° door stop may be required.

FLUSH INSET
TOP VIEW

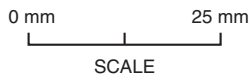

PRO 48 Refrigeration. Freshness finds unmistakable expression in the Sub-Zero PRO 48. A 363 kg monument to food preservation—equal parts sculpted metal design statement and culinary secret weapon. Its vast interior, like its bold exterior, is crafted of stainless steel. The PRO 48 is available with or without a glass door and may be either built in or freestanding.

PRO 48 MODELS

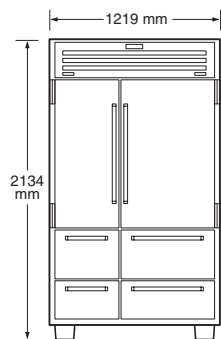

ICB648PRO

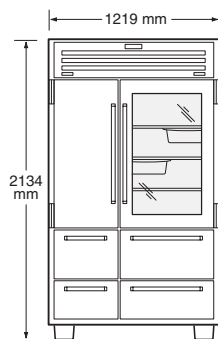

ICB648PROG

KEY FEATURES

- Can be used freestanding or installed as a standard or flush built-in application.
- Handles coordinate with handles of Wolf ranges.
- Stainless steel interior as well as exterior.
- Dual refrigeration system enhanced with triple evaporators allow independent control of storage conditions in refrigerator cabinet and drawer compartments.
- Exterior temperature display.
- Flip-up grille provides easy access for quick routine maintenance.
- Star-K certified.

PRO 48 Models

OVERALL DIMENSIONS

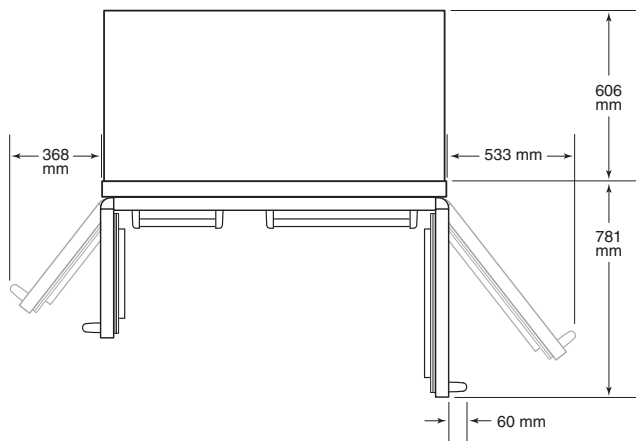
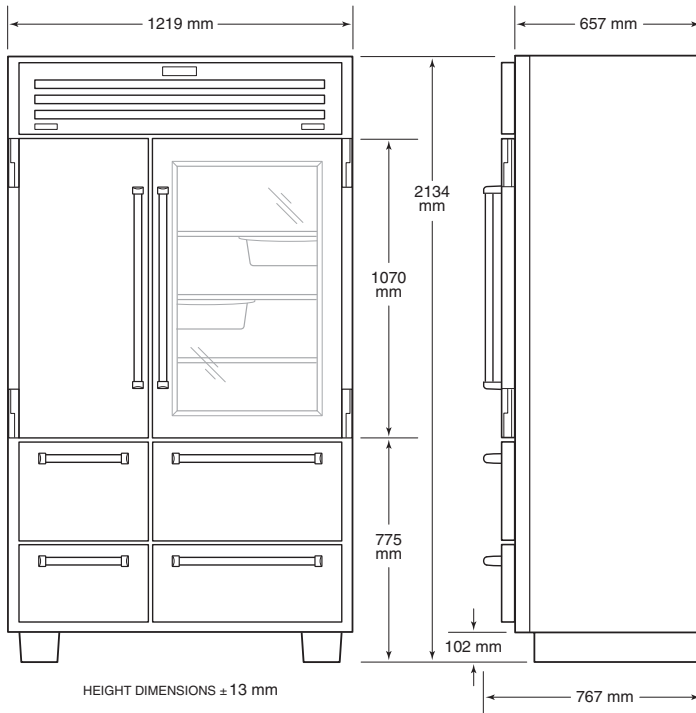

SPECIFICATIONS

Capacity / Weight		
INTERIOR CAPACITY	R (L)	F (L)
ICB648PRO and ICB648PROG	520	332
SHIPPING WEIGHT	KG	
ICB648PRO	390	
ICB648PROG	397	

MODELS ICB648PRO AND ICB648PROG

PRO 48 Models

STANDARD AND FLUSH BUILT-IN INSTALLATIONS

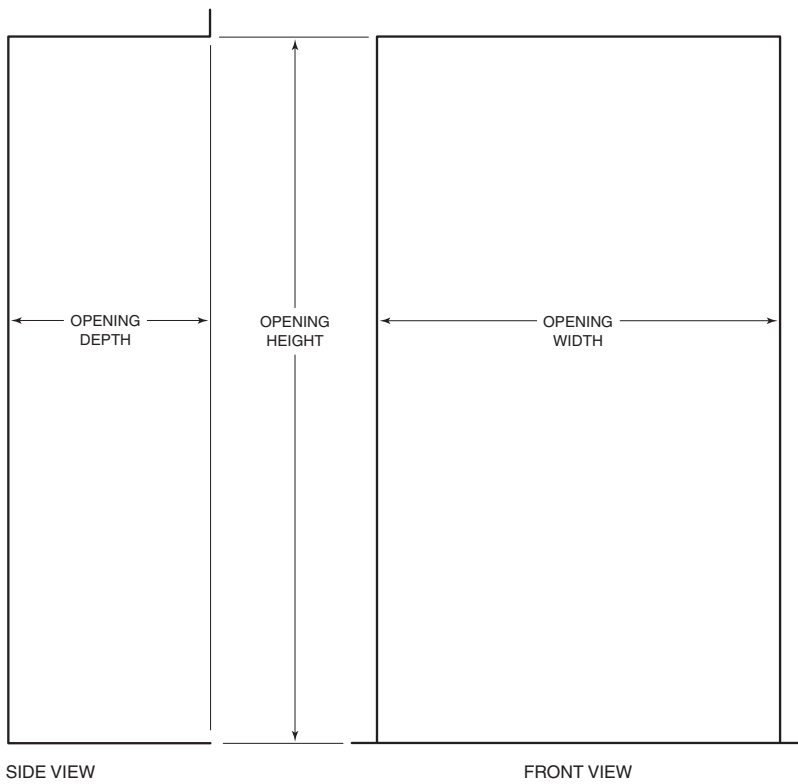
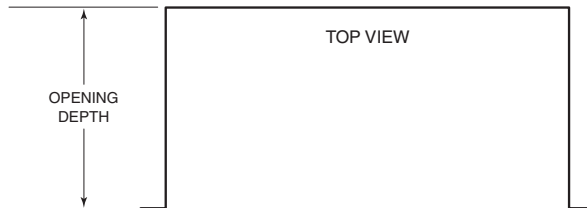

Opening Dimensions	Standard	Flush
Opening Width	1206 mm	1219 mm
Opening Height	2127 mm	2137 mm
Opening Depth	610 mm	660 mm

IMPORTANT NOTE: For standard built-in installations, the face frame of the unit will extend 51 mm beyond cabinetry. In flush built-in installations, the front of the face frame will be flush with surrounding cabinetry.

Planning Information

PRO 48 models can be used freestanding or installed as a standard or flush built-in application. For standard built-in installations, the face frame of the unit will extend 51 mm beyond cabinetry. In flush built-in installations, the front of the face frame will be flush with surrounding cabinetry.

ELECTRICAL REQUIREMENTS

International models from the factory designed without a transformer require a 220-240 V AC, 50/60 Hz electrical supply, fused at the correct rating for the unit. If required by local or national codes, the power cord can be easily replaced using the power inlet device.

For PRO 48 models, the electrical supply should be located within the shaded area shown in the illustration below. Follow local codes and ordinances when installing the receptacle. A separate circuit, servicing only this appliance, is required. A ground fault circuit interrupter (GFCI) is not recommended and may cause interruption of operation.

Electrical Requirements	
Power Supply	220-240 V AC, 50/60 Hz
Circuit Breaker	10 amp
Receptacle	3-prong grounding-type

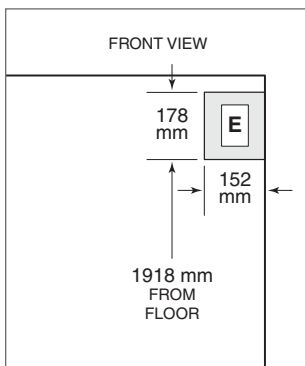

Location of electrical supply.

PLUMBING REQUIREMENTS

PRO 48 models come with an automatic ice maker. The water supply line should be located within the shaded area shown in the illustration below. The water supply line should be connected to the house supply with an easily accessible shut-off valve between the supply and the unit. Do not use self-piercing valves. A saddle valve kit (4200880) is available through your authorized Sub-Zero dealer. The water line must not interfere with installation of the anti-tip brackets.

IMPORTANT NOTE: A reverse osmosis system can be used provided there is constant water pressure of 2.4 bar to 8.3 bar supplied to the unit at all times.

Plumbing Requirements	
Water Supply Line	6.35 mm OD copper line
Water Pressure	2.4–8.3 bar
Excess Water Line for Connection	914 mm

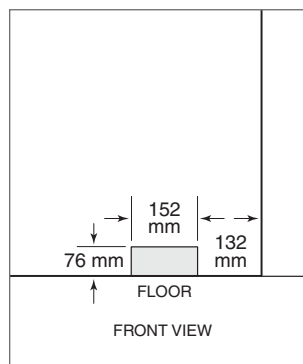

Location of water supply.

Accessories

These optional accessories are available through your authorized Sub-Zero dealer. For local dealer information, visit the find a showroom section of our website, subzero.com.

- Freestanding kit, which contains two stainless steel side panels and top lid.
- Stainless steel side panel.
- Refrigerator drawer dividers for compartmentalized storage.
- Stainless steel slide-out refrigerator bin.
- Dozen egg container.
- 90° door stop.

Integrated Refrigeration. With custom cabinet fronts and hardware, Sub-Zero invented integrated drawers and tall units that disappear into the decor. Integrated units fit flush with other cabinets, making integrated refrigeration as practical and beautiful in the master suite, bar or theatre room as in the kitchen.

INTEGRATED MODELS

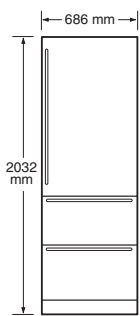

ICB700TR

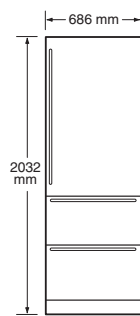

ICB700TCI

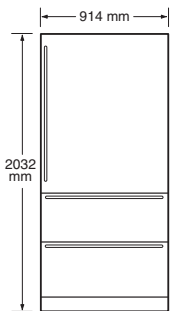

ICB736TR

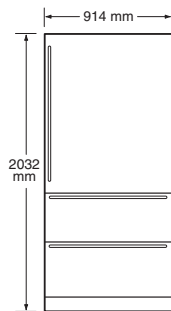

ICB736TCI

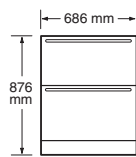

ICB700BR

KEY FEATURES

- Custom cabinet fronts and hardware allow for infinite design options.
- Point-of-use refrigeration that can be placed anywhere in the home.
- Dual refrigeration; two compressors preserve food's goodness in self-contained compartments.
- Energy efficient.
- Drawer model is Star-K certified.

Overall Dimensions

686 mm TALL MODELS

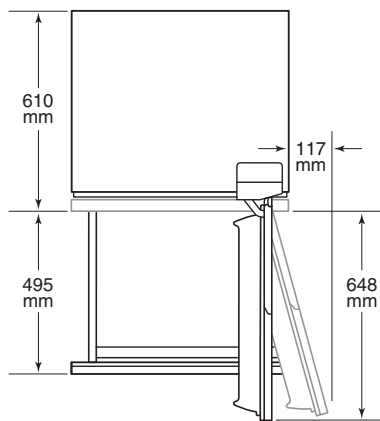
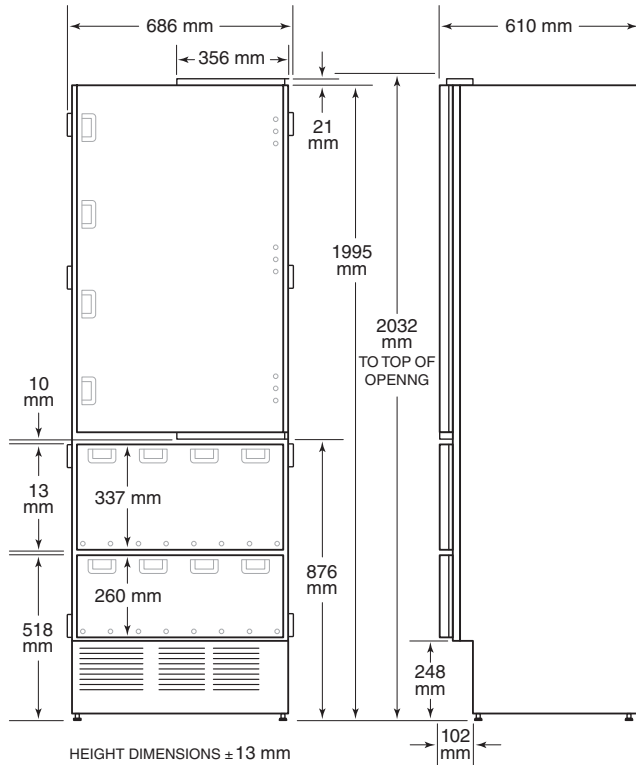

DIMENSIONS WILL VARY WITH PANEL THICKNESS

MODELS ICB700TR AND ICB700TCI

914 mm TALL MODELS

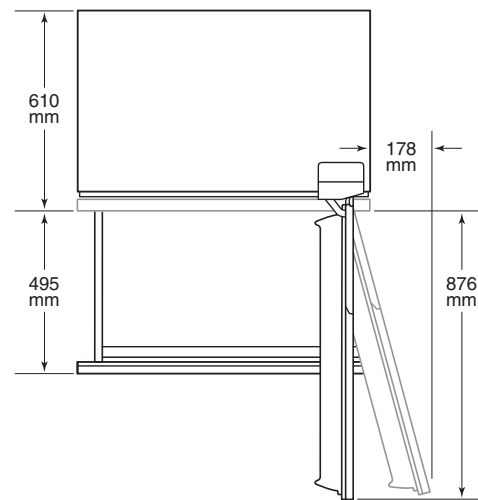
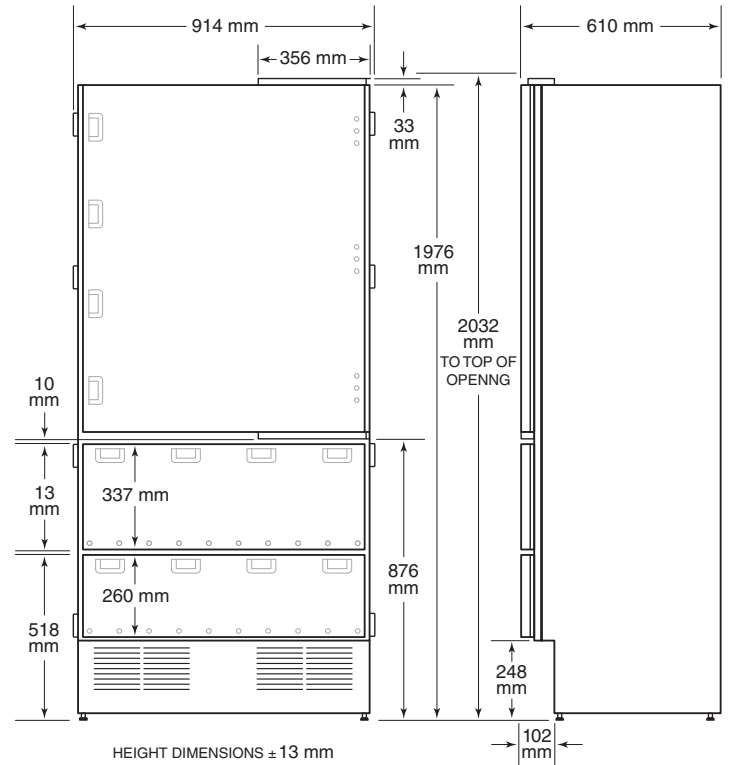

DIMENSIONS WILL VARY WITH PANEL THICKNESS

MODELS ICB736TR AND ICB736TCI

Overall dimensions do not include panels or handles.

Overall Dimensions

DRAWER MODELS

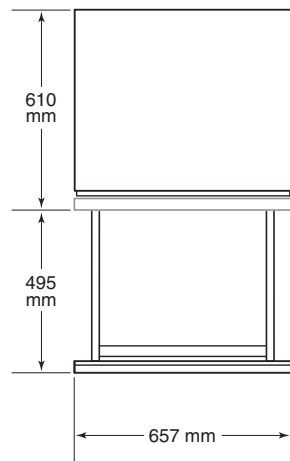
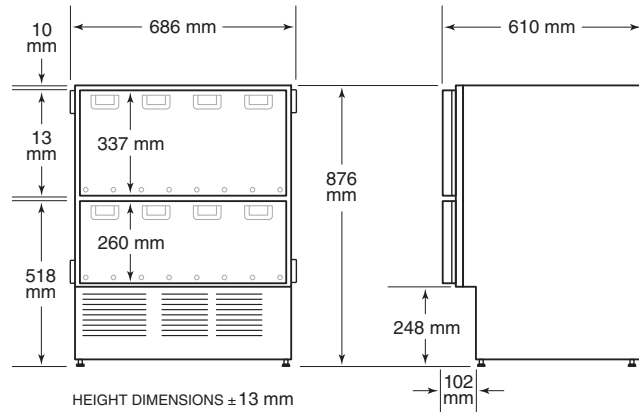

MODEL ICB700BR

Capacity and Weight

Interior Capacity	R (L)	F (L)
686 mm TALL MODELS		
ICB700TR	439	
ICB700TCI	288	143
914 mm TALL MODELS		
ICB736TR	590	
ICB736TCI	378	200
686 mm DRAWER MODEL		
ICB700BR	149	

Shipping Weight	kg
ICB700TR and ICB700TCI	163
ICB736TR and ICB736TCI	218
ICB700BR	86

Opening Dimensions

INTEGRATED MODELS

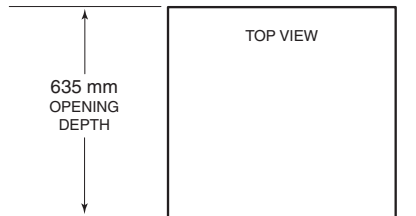

IMPORTANT NOTE: The depth of each integrated model is 610 mm from the front of the unit to its back. Your design may necessitate moving the unit back or cabinets forward to achieve a flush fit. This will require a minimum rough opening depth of 635 mm.

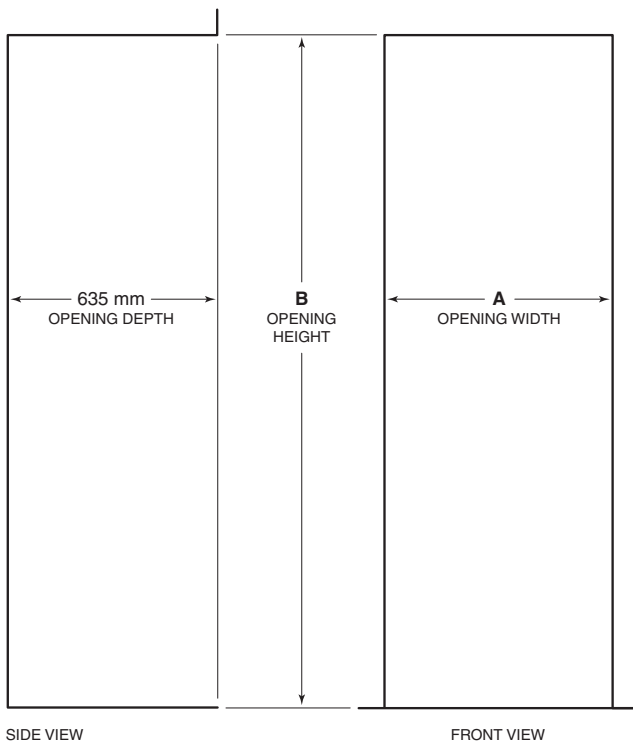

Opening Dimensions	A	B
ICB700TR, ICB700TCI	686 mm	2032 mm
ICB736TR, ICB736TCI	914 mm	2032 mm
ICB700BR	686 mm	876 mm

Electrical Requirements

International models from the factory designed without a transformer require a 220-240 V AC, 50/60 Hz electrical supply, fused at the correct rating for the unit. If required by local or national codes, the power cord can be easily replaced using the power inlet device.

The electrical supply should be located within the shaded area shown in the illustrations. Follow local codes and ordinances when installing the receptacle. A separate circuit, servicing only this appliance, is required. A ground fault circuit interrupter (GFCI) is not recommended and may cause interruption of operation.

IMPORTANT NOTE: It is critical that the electrical outlet be located within the shaded area shown so it does not interfere with installation of the anti-tip bracket. It must be flush with the back wall and positioned with the grounding prong to the right of the thinner blades.

Electrical Requirements	
Power Supply	220-240 V AC, 50/60 Hz
Circuit Breaker	10 amp
Receptacle	3-prong grounding-type

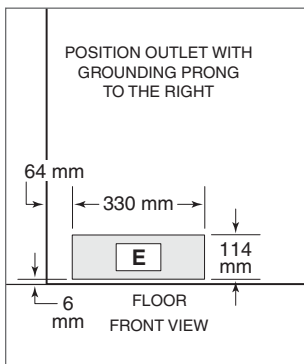

686 mm models.

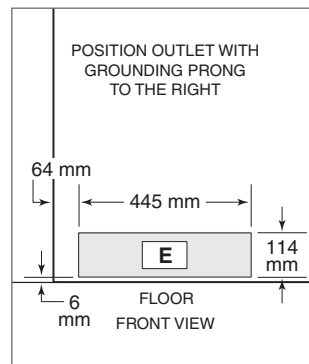

914 mm models.

Plumbing Requirements

For integrated models with an automatic ice maker, the water supply line should be located through the floor or back wall, within the shaded area shown in the illustrations. The water supply line should be connected to the house supply with an easily accessible shut-off valve between the supply and the unit. Do not use self-piercing valves. A saddle valve kit (4200880) is available through your authorized Sub-Zero dealer.

IMPORTANT NOTE: It is critical that the water line be located within the shaded area shown so it does not interfere with installation of the anti-tip bracket.

An in-line filter is required when water conditions have a high sediment content. The ice maker operates on constant water pressure between 1.4 bar and 6.9 bar.

IMPORTANT NOTE: In some cases, a reverse osmosis water filter system may not be able to maintain the minimum pressure consistently.

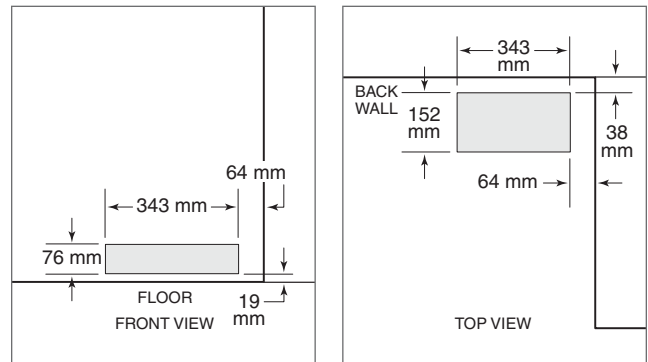

914 mm models.

Plumbing Requirements	
Water Supply Line	6.35 mm OD copper line
Water Pressure	1.4–6.9 bar
Excess Water Line for Connection	686 mm

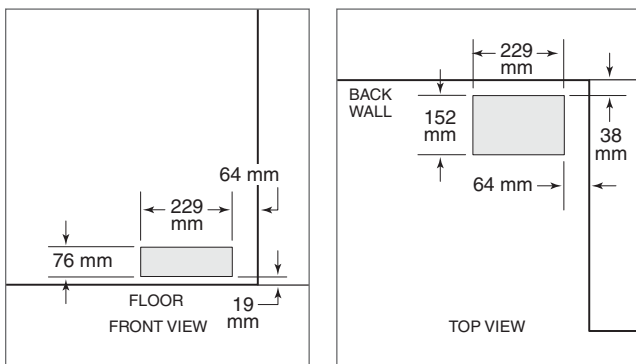

686 mm models.

Cabinetry Applications

FRAMELESS CABINERY

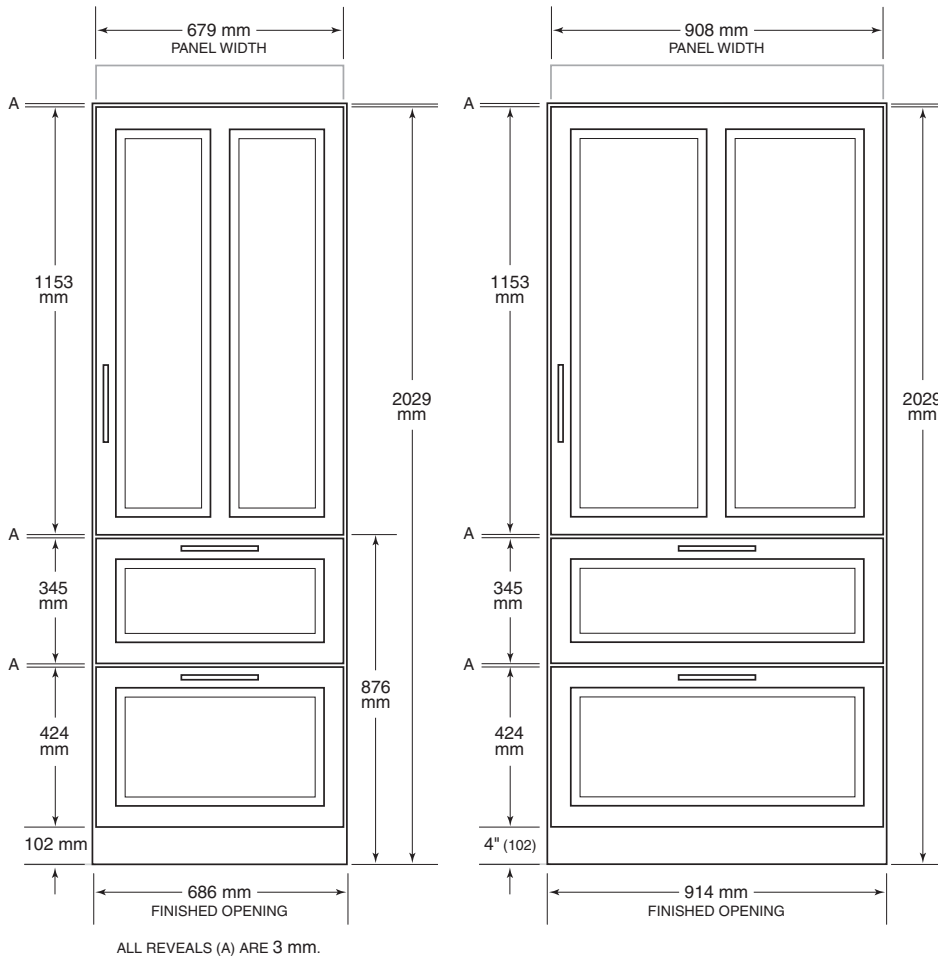

686 mm MODELS

TALL AND DRAWER MODELS

914 mm MODELS

TALL MODELS

Typical Panel Dimensions		
686 mm MODELS		
	W	H
Door	679 mm	1153 mm
Top Drawer	679 mm	345 mm
Bottom Drawer	679 mm	424 mm
914 mm MODELS		
	W	H
Door	908 mm	1153 mm
Top Drawer	908 mm	345 mm
Bottom Drawer	908 mm	424 mm

Panel dimensions are based on a 3 mm reveal. A reveal of up to 6 mm is possible with adjustments to panel dimensions.

Cabinetry Applications

DOOR PANEL HEIGHT

The height of the door panel can extend beyond the typical panel height, provided you do not exceed the panel weight limit. The illustration below shows how the panel may be extended and what you need to consider to finish the area behind the door panel.

IMPORTANT NOTE: The decorative valance used to finish the area behind the door panel must stay behind the front plane of the finished molding.

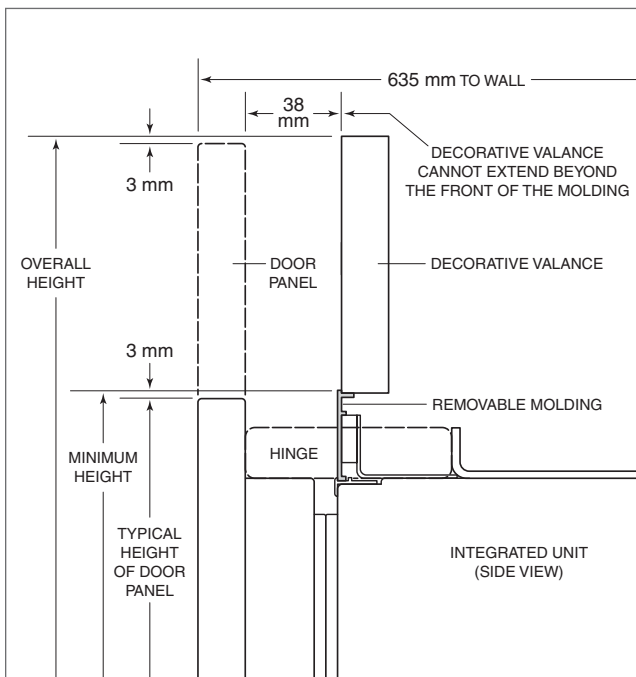

UPPER VALANCE

TALL MODELS

TOE KICK CLEARANCE

The toe kick clearance can vary with the height of the panel. You must keep a minimum space of 102 mm clear below the bottom edge of the panel for proper venting. In addition, any decorative base molding must be removable to clean the condenser and for service.

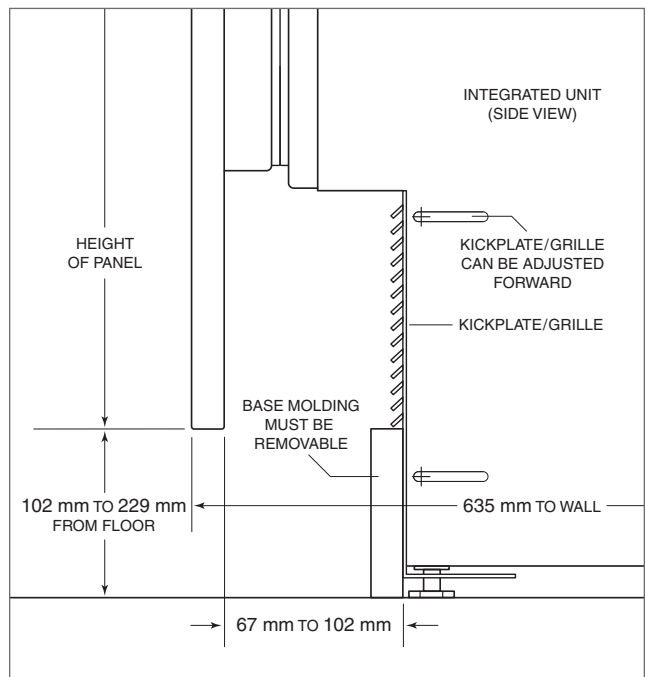

KICKPLATE/GRILLE AREA

ALL INTEGRATED MODELS

Cabinetry Applications

Integrated refrigeration is compatible with virtually any style and look of cabinetry. These models can be used with framed as well as frameless cabinetry. Because of the precise application and the look you may want to achieve, keep the following considerations in mind:

The thickness of the front panels can vary. A minimum 16 mm thick panel is required, but the thickness can be increased provided the panel weight limit is not exceeded.

IMPORTANT NOTE: The depth of each integrated model is 610 mm from the front of the unit to its back. You must allow for the thickness of the panel you are applying when planning for the finished rough opening depth if you want the front panel to be flush with surrounding cabinetry. You may have to move the unit back into drywall or bring the cabinets forward to achieve a flush fit.

Reveals between panels can vary. A reveal of 3 mm is typical, but reveals can be increased to up to 6 mm.

⚠ CAUTION
As reveals between cabinetry and the unit decrease, the potential exists for severe finger pinching while the door is closing.

⚠ CAUTION
When 19 mm or thicker panels are used with a reveal of less than 6 mm, door panels may cause damage to the unit when the door is opened to the maximum 105°. Use the built-in 90° door stop.

IMPORTANT NOTE: The inside edges of the rough opening as well as the sides and a portion of the backside of the decorative panels will need to be finished, as they will be exposed when the doors are open.

D-style handles are recommended. For the cabinet door, handles must be located near the edge of the panel opposite the hinge, centered top to bottom. Locate handles in the top center area of the drawer panels.

Illustrations on the following pages show typical applications of frameless and framed cabinetry. Also refer to the full-scale illustration at the end of this section for specifics on door openings.

Panel Requirements	
TALL AND DRAWER MODELS	MAX WEIGHT
686 mm Door Panel	18 kg
686 mm Drawer Panel	5 kg
914 mm Door Panel	24 kg
914 mm Drawer Panel	7 kg
PANEL THICKNESS	MINIMUM
All Panels	16 mm

Cabinetry Applications

The illustrations below show typical applications of framed and frameless cabinetry. Refer to the full-scale templates at the end of this section for specifics on door openings.

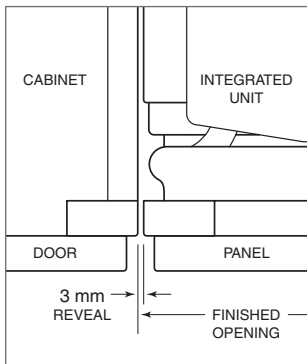

Framed—full overlay.

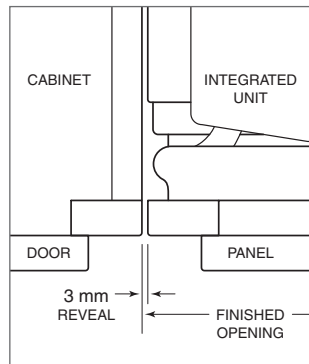

Framed—standard overlay.

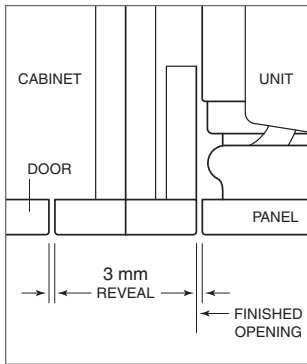

Framed—beaded inset.

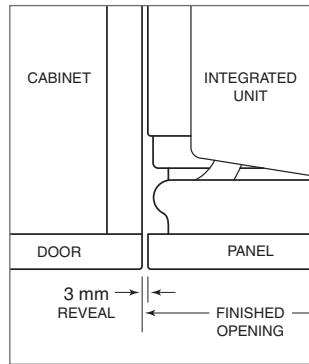

Frameless cabinetry.

Dual Installations

Two integrated units may be placed side by side in a dual installation. Depending on the models specified, opening widths will be 1372 mm, 1600 mm or 1829 mm. Panel width dimensions will vary slightly from single installations. Refer to the chart below for typical panel dimensions. The dimensions are based on a 3 mm reveal. A reveal of up to 6 mm is possible with adjustments to panel dimensions.

Typical Panel Dimensions		
686 mm MODELS	W	H
Door	681 mm	1153 mm
Top Drawer	681 mm	345 mm
Bottom Drawer	681 mm	424 mm
914 mm MODELS	W	H
Door	910 mm	1153 mm
Top Drawer	910 mm	345 mm
Bottom Drawer	910 mm	424 mm

A dual installation kit is required for installations with 51 mm or less space between the units. Dual installation kits are available through your authorized Sub-Zero dealer.

IMPORTANT NOTE: If a 686 mm unit is installed next to a 914 mm tall unit, the decorative front panels will align, however, the face frames will not. This is only apparent when both doors are open at the same time. Due to a more robust hinge on 914 mm units, the face frame was reconfigured to maintain a consistent overall panel height. Refer to the illustration below.

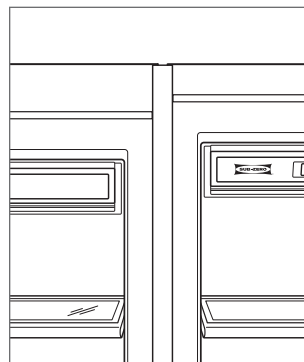

Face frame alignment.

Accessories

These optional accessories are available through your authorized Sub-Zero dealer. For local dealer information, visit the find a showroom section of our website, subzero.com.

- Stainless steel front panels with handles.
- Tubular and pro handles to match the style of Wolf ovens and ranges.
- Crisper drawer with shelf assembly, deli drawer with shelf and crisper cover with lid for certain models.
- Dual installation kit.
- Harness kit for Star-K compliance.

STANDARD HANDLE LENGTHS

Refer to the chart below for standard lengths of tubular and pro handles used on integrated models.

Standard Handle Lengths		
686 mm MODELS	DOOR	DRAWER
Tubular Handle	1053 mm	584 mm
Pro Handle	1003 mm	533 mm
Stud Spacing	975 mm	502 mm
914 mm MODELS	DOOR	DRAWER
Tubular Handle	1053 mm	762 mm
Pro Handle	1003 mm	533 mm
Stud Spacing	975 mm	730 mm

Maximum Door Opening

FULL-SCALE TEMPLATE

If the panel is thicker than 19 mm, use the built-in 90° door stop to prevent damage to the panel and face frame at the maximum door opening.

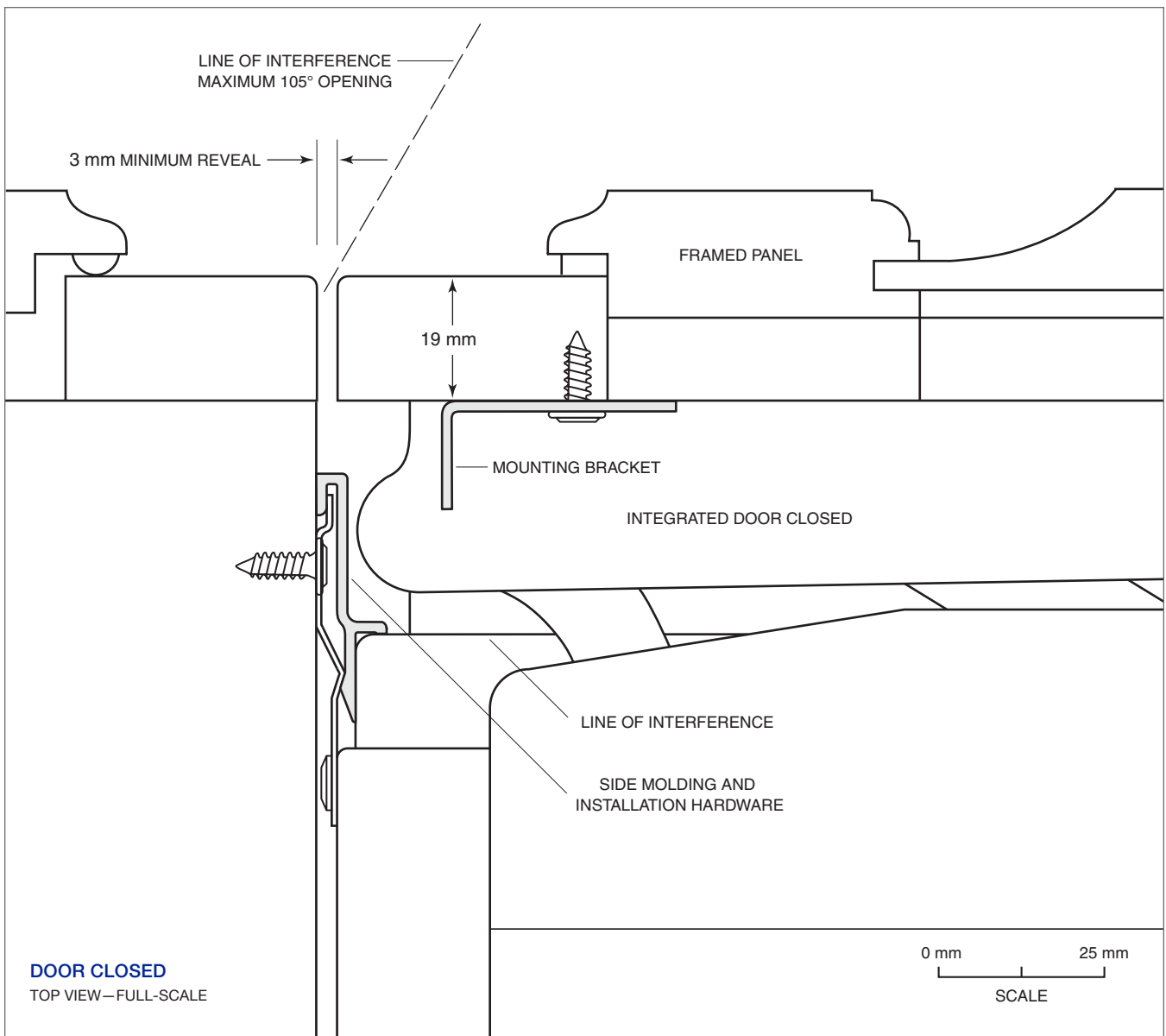
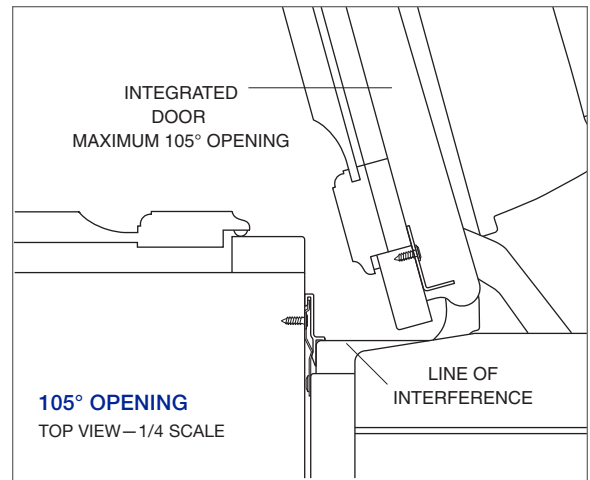

Wine Storage. Wine finds a well-deserved place of honor in a Sub-Zero wine storage unit. Every detail is designed to ensure better wine preservation. Cherrywood-faced shelves, soft lighting, custom cabinetry if desired—Sub-Zero helps make a wine collection an element of beauty in the home.

WINE STORAGE MODELS

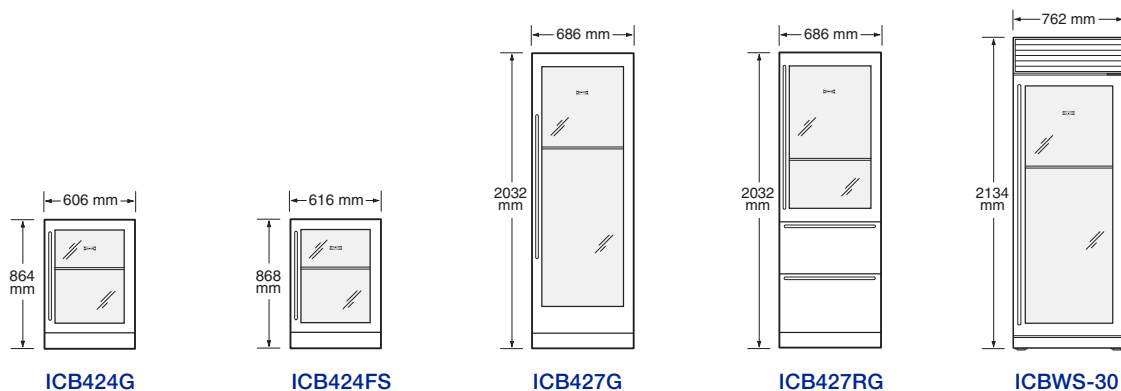

KEY FEATURES

- Integrated, overlay, flush inset and stainless steel design options.
- Full-view glass door standard on all models.
- Freestanding model ICB424FS does not require panels or surrounding cabinetry.
- Discreet interior lighting with illuminated display shelf.
- Two independent storage zones maintain temperature, humidity and UV protection.
- Cherrywood shelf fronts display the wine beautifully.
- Rust-proof metal shelves accommodate 750 ml bottles, half-bottles and magnums.

Overall Dimensions

UNDERCOUNTER WINE STORAGE

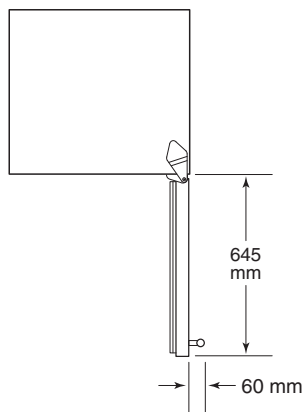
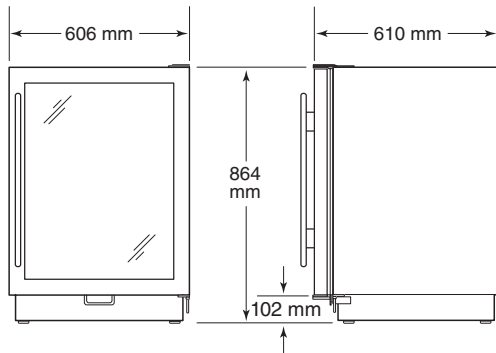

MODEL ICB424G

Overall dimensions are based on stainless steel panels and handles.

Overall Dimensions

FULL-SIZE WINE STORAGE

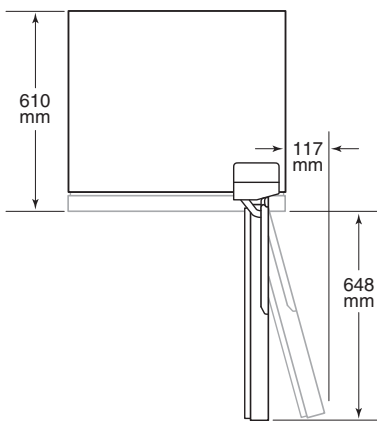
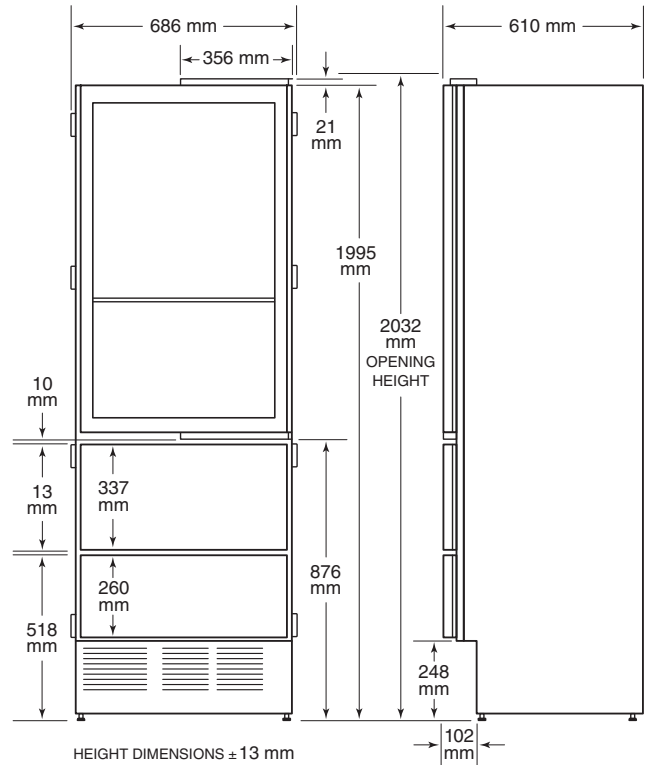
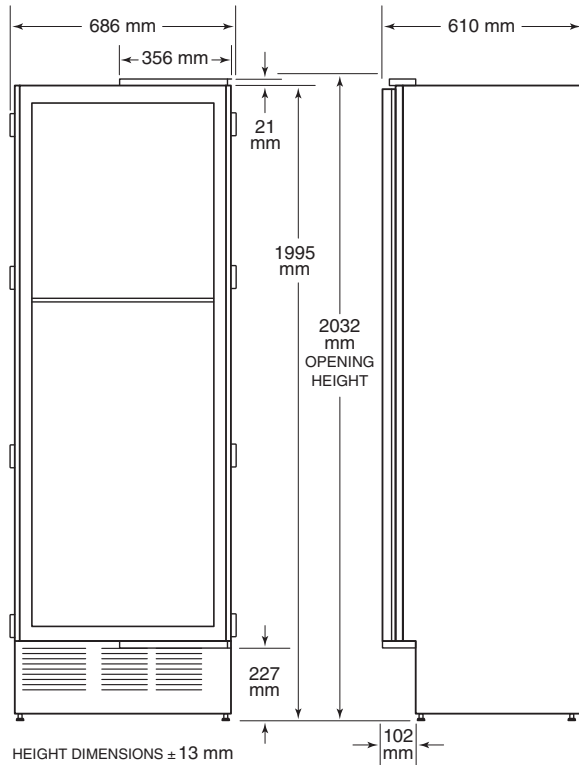

DIMENSIONS WILL VARY WITH PANEL THICKNESS

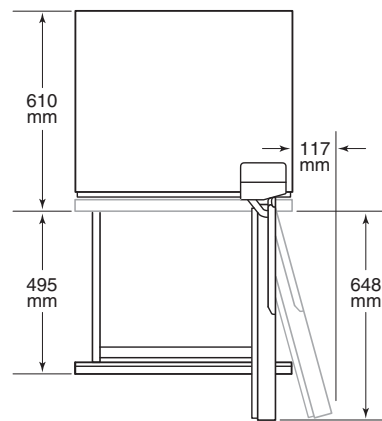

DIMENSIONS WILL VARY WITH PANEL THICKNESS

MODEL ICB427G

MODEL ICB427RG
WITH REFRIGERATOR DRAWERS

Overall dimensions do not include panels or handles.

Overall Dimensions

FULL-SIZE WINE STORAGE

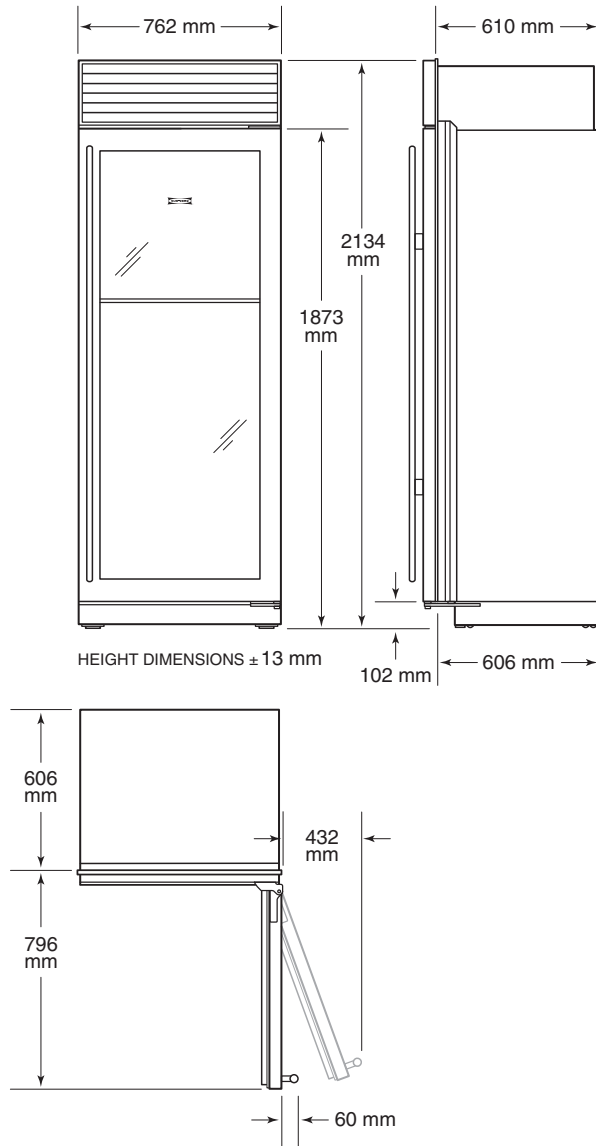

Capacity and Weight

Storage Capacity	Bottles (750 ml)	R (L)
ICB424G	46	
ICB427G	132	
ICB427RG	78	150
ICBWS-30	147	

Shipping Weight	kg
ICB424G	88
ICB424FS	100
ICB427G	179
ICB427RG	186
ICBWS-30	202

MODEL ICBWS-30

Overall dimensions are based on the stainless steel model. For flush inset applications, add 13 mm to door clearance dimensions.

Opening Dimensions

UNDERCOUNTER WINE STORAGE

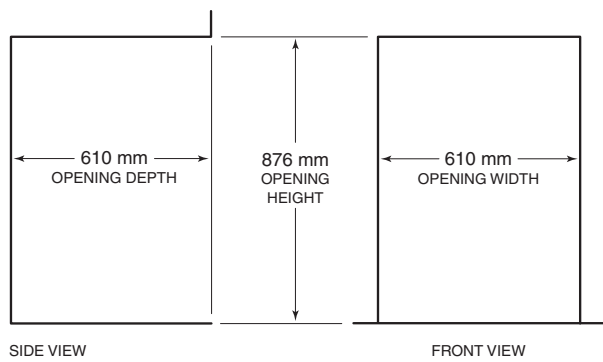
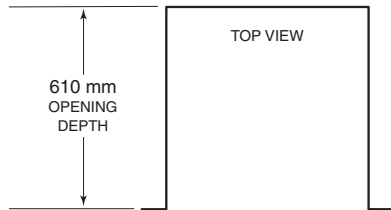

MODEL ICB424G

FULL-SIZE WINE STORAGE

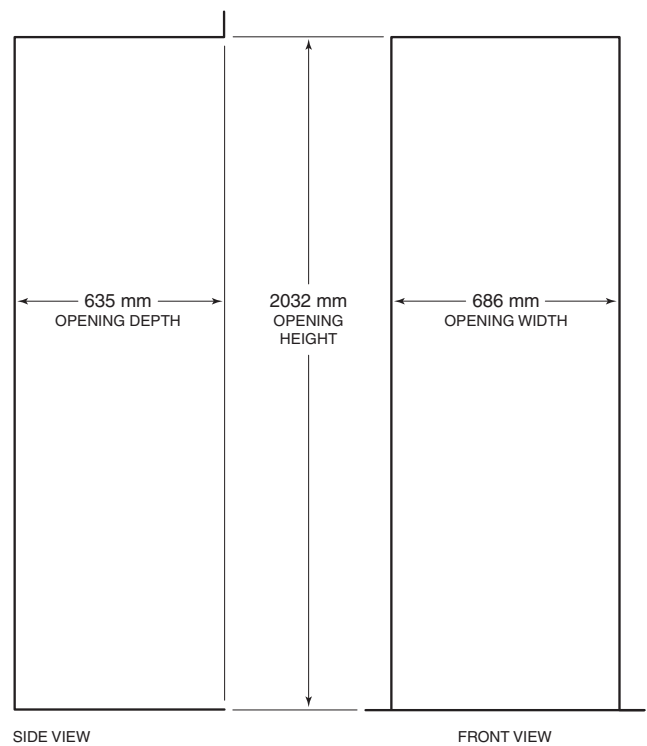
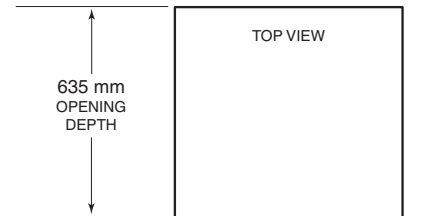

MODELS ICB427G AND ICB427RG

IMPORTANT NOTE: The depth of each integrated model is 610 mm from the front of the unit to its back. Your design may necessitate moving the unit back or cabinets forward to achieve a flush fit. This will require a minimum rough opening depth of 635 mm.

Opening Dimensions

FULL-SIZE WINE STORAGE

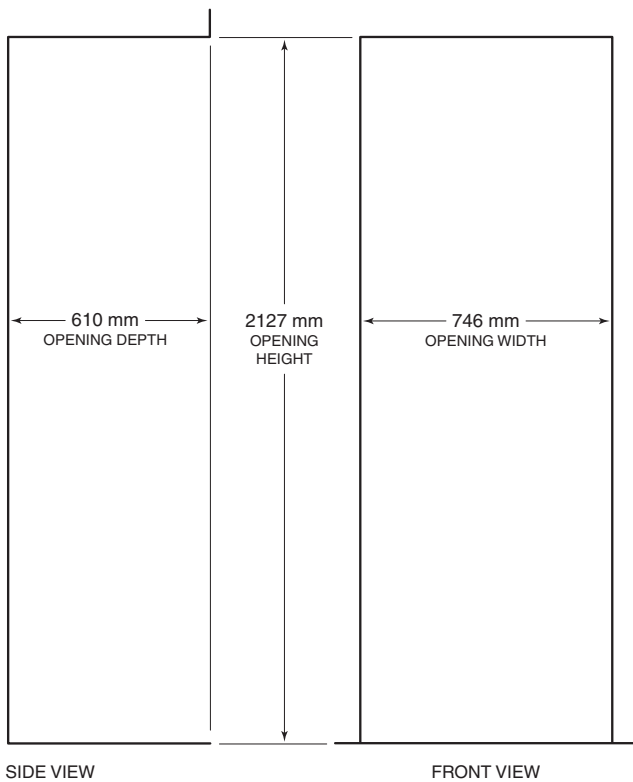
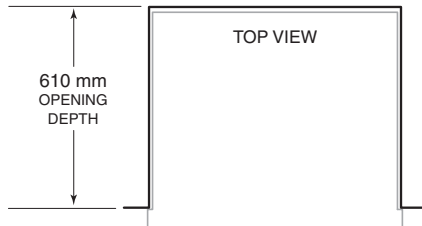

MODEL ICBWS-30

Planning Information

All wine storage models must be installed so that the door can open a minimum of 90° or you will have problems pulling the wine shelves out. For corner installations, you need to allow for a minimum 76 mm filler so the door can open to 90°. If you are using larger-handle hardware, you will also need to take that into account. Refer to door clearance specifications.

For a maximum 90° door opening, use the door stop built into the hinge system of model ICB427G. A 90° door stop is shipped with model ICBWS-30.

If you will be connecting the unit to a home security system, you must allow a minimum of 914 mm of the system's wiring to be routed in the electrical area designated for your model.

Planning Information

DUAL INSTALLATIONS

If you are installing a wine storage unit next to an existing Sub-Zero unit, you may have to allow for a filler strip.

If you are installing a model ICB427G or ICB427RG next to an existing integrated unit, with 51 mm or less between the units, an optional heater kit will need to be installed to prevent moisture from forming between the units. These optional heater kits are available through your authorized Sub-Zero dealer. For local dealer information, visit the find a showroom section of our website, subzero.com.

ELECTRICAL REQUIREMENTS

International models from the factory designed without a transformer require a 220-240 V AC, 50/60 Hz electrical supply, fused at the correct rating for the unit. If required by local or national codes, the power cord can be easily replaced using the power inlet device.

The electrical supply should be located within the shaded area shown in the illustration for your specific model. Follow local codes and ordinances when installing the receptacle. A separate circuit, servicing only this appliance, is required. A ground fault circuit interrupter (GFCI) is not recommended and may cause interruption of operation.

Electrical Requirements	
Power Supply	220-240 V AC, 50/60 Hz
Circuit Breaker	10 amp
Receptacle	3-prong grounding-type

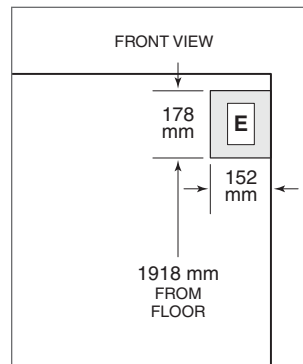

Model ICBWS-30.

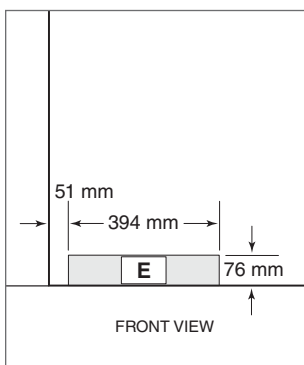

Model ICB424G.

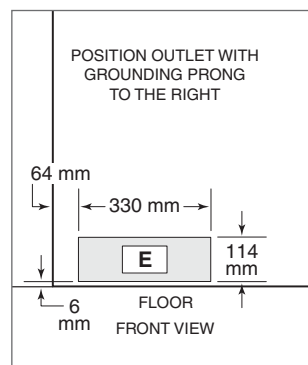

Models ICB427G and ICB427RG.

Door Panels

Unless you are installing a stainless steel model, you will need to provide a frame for the glass door. If you order a stainless steel unit, models ICB424G, ICB424FS and ICBWS-30 will be shipped with their panels and hardware installed. For models ICB427G and ICB427RG, optional stainless steel panels or custom panels will need to be installed.

The glass door is designed to be exposed to room air circulation. Decorative overlays on the glass should be kept to a minimum. Also, rails and stiles can be increased in size but should not exceed the cabinet manufacturers' standard width and cannot exceed the overall door panel dimensions listed in the charts.

The back sides of rails and stiles that will be visible through the glass door will need to be finished. Also, the inside edges of the frames must be finished to match the front surface.

FREESTANDING MODEL ICB424FS

Model ICB424FS does not require any panels or surrounding cabinetry. It has a beautiful stainless steel exterior that is designed to be used in a freestanding application.

Overlay Panels

MODEL ICB424G

The overlay panel applied to model ICB424G should not be confused with the built-in overlay panel application. The overlay panel will consist of just a frame and would be either the 16 mm or 19 mm thick panel you may be using. It is affixed directly to the door itself with screws through a series of predrilled holes in the door frame. A backer and spacer panel is not required.

Model ICB424G can be installed flush with surrounding cabinetry. Depending on the thickness of the overlay door panel, it may be necessary to install the unit so that it extends 6 mm beyond the front surface of surrounding cabinetry. This will prevent interference between the door panel and adjoining cabinetry at the maximum 145° door swing. Refer to the full-scale template at the end of this section.

Overlay Panels		
PANEL DIMENSIONS	W	H
ICB424G	603 mm	764 mm
MIN WIDTH		
Stiles and Rails		57 mm
MAX PANEL WEIGHT		
Door Frame		5 kg
MIN PANEL THICKNESS		
All Panels		16 mm

Integrated Panels

MODELS ICB427G AND ICB427RG

The integrated full panels or frame panels for glass doors for these models will follow some of the identical planning processes used with the integrated line. The installation of the door panels is completely different, however. Rather than using the mounting hardware we used with the integrated line, door panels for both models ICB427G and ICB427RG will be applied with screws applied through our door.

The drawer panels for the model ICB427RG will be applied using the integrated technique of mounting brackets.

IMPORTANT NOTE: The depth of models ICB427G and ICB427RG is 610 mm from the front of the unit to its back. You must allow for the thickness of the panel you are applying when planning for the finished rough opening depth if you want the front panel to be flush with surrounding cabinetry. You may have to move the unit back into the drywall or bring the cabinets forward. Refer to the integrated section.

Panel dimensions listed in the chart assume the models finish off at 2032 mm in height overall and have a 102 mm toe kick for the model ICB427G. If you finish off at 2134 mm, for instance, you must add an additional 102 mm to the finished height of the panel and 102 mm to the top rail. Likewise, if you allow for a 152 mm toe kick for the model ICB427G, you must subtract 51 mm from the bottom rail.

The height of the door panel for models ICB427G and ICB427RG can extend beyond the typical panel height, provided you do not exceed the panel weight limit. Refer to specifications on page 46 of the integrated section.

The toe kick area on model ICB427G cannot be larger than 152 mm, and on model ICB427RG, no larger than 229 mm. The toe kick area for either model cannot be less than 102 mm.

If you are installing an optional lock kit on models ICB427G or ICB427RG, you may have to order door panels that exceed the 2032 mm finished height. Consult the lock kit installation instructions and see if your panels will allow for an adequate installation. These instructions are available on our website, subzero.com.

Integrated Panels

ICB427G	W	H
Door	679 mm	1927 mm
ICB427RG	W	H
Door	679 mm	1153 mm
Top Drawer	679 mm	345 mm
Bottom Drawer	679 mm	424 mm

Panel Requirements

MIN WIDTH	
Stiles	57 mm
Top Rail	95 mm
Bottom Rail (ICB427G)	203 mm
Bottom Rail (ICB427RG)	76 mm
MAX PANEL WEIGHT	
Door Frame	9 kg
Drawer Panel (ICB427RG)	5 kg
MIN PANEL THICKNESS	
All Panels	16 mm

Model ICBWS-30

OVERLAY PANEL

Overlay model ICBWS-30 can be used in an overlay or flush inset application. The specific application will affect panel sizes, opening dimensions and the installation.

Overlay model ICBWS-30 will be shipped without handle hardware and with an overlay panel grille as standard equipment. Along with the door panel, you will need to provide a panel for the grille and hardware to complement your surrounding cabinetry.

The overlay design allows the decorative panel to cover the door trim for a more seamless appearance. The most common way to achieve this look is to work with three panels—the decorative overlay panel, which is typically 19 mm, a 3 mm spacer panel and a 6 mm backer panel. Depending on your cabinet manufacturer, this could be one panel routed for different dimensions. The illustrations below will give you a better idea of the panel construction and how it interacts with our frame. The size of the overlay panel is critical, it must fit over the door frame.

IMPORTANT NOTE: Do not cover the glass door with a solid panel. The window cut-out edges of the overlay, spacer and backer panels will need to be finished, as they will be exposed.

Overlay Panel Requirements	
MODEL ICBWS-30	
Max Panel Weight	34 kg
Min Panel Thickness	16 mm

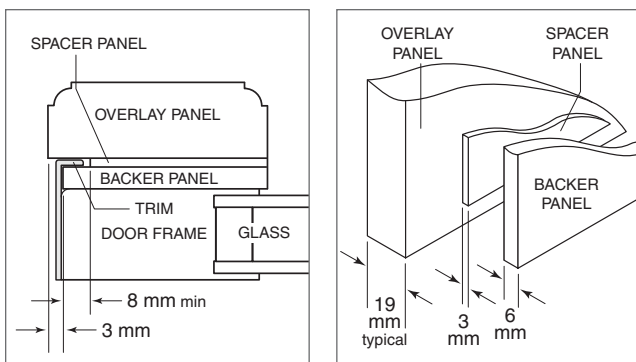

Panel assembly cross section. Panel assembly rear view.

OVERLAY PANEL SPECIFICATIONS

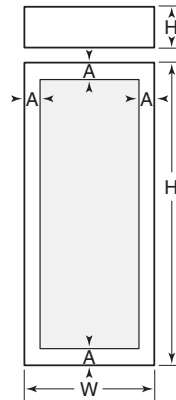

ICBWS-30 Overlay		
DOOR	W	H
Overlay Panel	762 mm	1772 mm
Spacer Panel	740 mm	1751 mm
Backer Panel	756 mm	1767 mm
GRILLE	W	H
Overlay Panel	762 mm	235 mm
Spacer Panel	740 mm	211 mm
Backer Panel	756 mm	227 mm
WINDOW	W	H
Cut-Out	597 mm	1607 mm
Location		A
		83 mm

Grille panel dimensions listed are for a standard 2134 mm overall height of the unit. For a 2108 mm overall height, subtract 25 mm from grille panel height dimensions. For a 2235 mm overall height, add 102 mm to height dimensions. Width dimensions do not vary.

CAUTION
Do not exceed overlay panel dimensions, as this could cause damage to panels and the Sub-Zero unit.

Model ICBWS-30

FLUSH INSET PANEL

Overlay model ICBWS-30 used in a flush inset application allows the decorative panel to cover the door trim for a seamless appearance. The most common way to achieve this look is to work with three panels—the decorative flush inset panel, which is typically 19 mm, a 3 mm spacer panel and a 6 mm backer panel. Depending on your cabinet manufacturer, this could be one panel routed for different dimensions. The illustrations below will give you a better idea of the panel construction and how it interacts with our frame. The size of the flush inset panel is critical, it must fit over the door frame.

IMPORTANT NOTE: Do not cover the glass door with a solid panel. The inside edges of the rough opening as well as the sides and a portion of the back side of the decorative panels will need to be finished, as they will be exposed when the doors are open. The window cut-out edges of the overlay, spacer and backer panels will also need to be finished.

IMPORTANT NOTE: For flush inset panels thicker than 19 mm, a 90° door stop may be required to prevent interference with adjacent cabinets.

Flush Inset Panel Requirements	
MODEL ICBWS-30	
Max Panel Weight	34 kg
Min Panel Thickness	16 mm

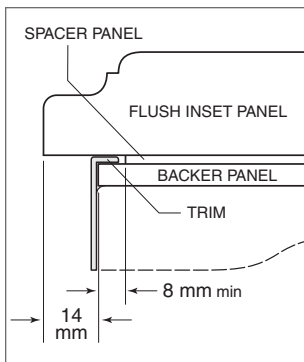

Panel assembly cross section.

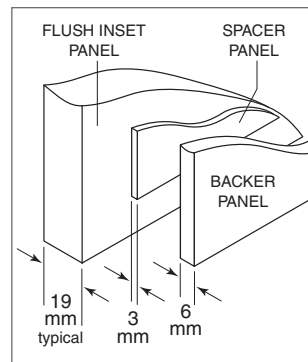

Panel assembly rear view.

FLUSH INSET PANEL SPECIFICATIONS

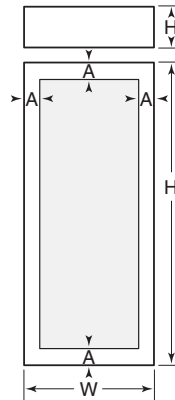

ICBWS-30 Flush Inset		
DOOR	W	H
Flush Inset Panel	787 mm	1772 mm
Spacer Panel	740 mm	1751 mm
Backer Panel	756 mm	1767 mm
GRILLE	W	H
Flush Inset Panel	787 mm	235 mm
Spacer Panel	740 mm	211 mm
Backer Panel	756 mm	227 mm
WINDOW	W	H
Cut-Out	597 mm	1581 mm
Location		A 95 mm

Grille panel dimensions listed are for a standard 2134 mm overall height of the unit. For a 2108 mm overall height, subtract 25 mm from grille panel height dimensions. For a 2235 mm overall height, add 102 mm to height dimensions. Width dimensions do not vary.

CAUTION
Do not exceed flush inset panel dimensions, as this could cause damage to panels and the Sub-Zero unit.

Model ICBWS-30

FLUSH INSET PANEL

Illustrations A–D provide panel offsets and reveals for model ICBWS-30 in a flush inset application. Refer to the chart below for reference to the illustrations.

For additional information on panel reveals, visit the specification library section of our website, subzerotrade.com.

Panel Offsets	Illus.
MODEL ICBWS-30	
Door / Grille Sides	A
Grille Top	B
Grille Bottom / Door Top	C
Door Bottom	D

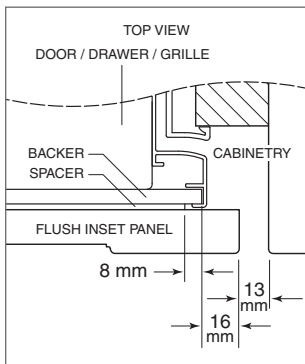

Illus. A

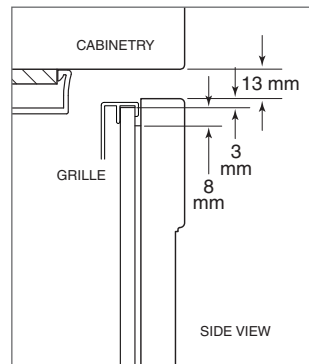

Illus. B

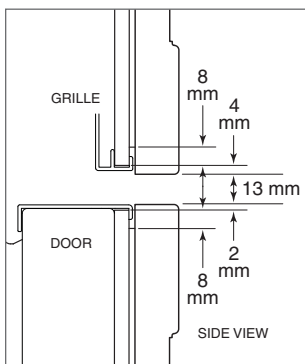

Illus. C

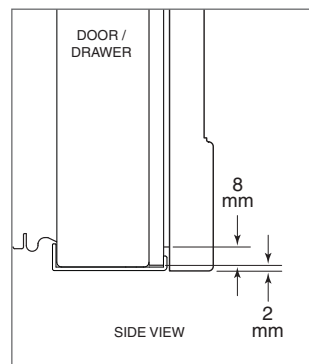

Illus. D

DUAL INSTALLATIONS

When two models ICBWS-30 or a model ICBWS-30 and built-in unit are installed side by side, a dual installation kit may be required. Contact your Sub-Zero dealer for the proper components and installation instructions. For questions relative to the installation, contact your Sub-Zero dealer. To obtain local dealer information, visit the find a showroom section of our website, subzero.com.

DUAL STANDARD INSTALLATIONS

Two overlay or stainless steel units may be placed side by side in a dual installation. Some dual standard installations will require a dual installation kit, available through your Sub-Zero dealer.

A custom filler strip can be used in between two units in an overlay or stainless steel design application. It is recommended that the filler strip be at least 51 mm wide, to prevent condensation between the units. Be sure to add the filler strip width to your rough opening width.

Dual installations without a filler strip can only be accomplished using two units with opposite hinges as shown in illustration A below. The dual installations shown in illustrations B and C require a filler strip.

IMPORTANT NOTE: For the application shown in illustration A, a dual installation accessory kit is required.



Illus. A

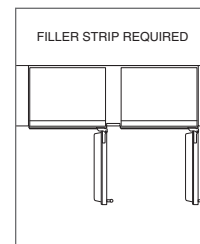

Illus. B

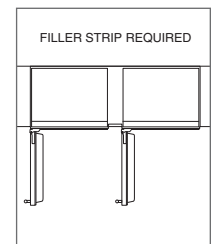

Illus. C

Model ICBWS-30

DUAL FLUSH INSET INSTALLATIONS

Installing two models ICBWS-30 or a model ICBWS-30 and built-in unit side by side in a flush inset application will require adjustments to the dimensions of your finished rough opening, panel sizes and panel offsets. It will also require a dual installation kit, available through your Sub-Zero dealer.

Dual installations without a filler strip can only be accomplished using two units with opposite hinges as shown in illustration A below. The dual installations shown in illustrations B and C require a filler strip. Illustration A is the only application that will accommodate the dual wide grille.

IMPORTANT NOTE: The application shown in illustration A can only be achieved by installing dual flush inset panels. Failure to install dual flush inset panels will cause the handle side of the panels to collide when closing. In this application a dual installation accessory kit is also required.

Dual flush inset panels and dual installation kits are available through your Sub-Zero dealer. Refer to the illustration and chart for dual flush inset panel specifications.

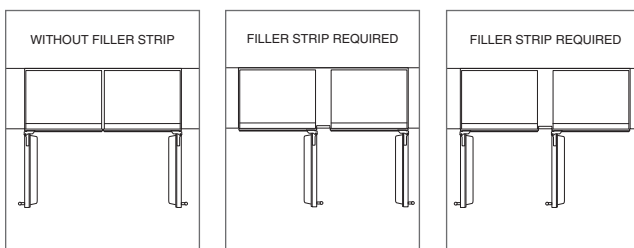

Illus. A

Illus. B

Illus. C

DUAL FLUSH INSET PANEL SPECIFICATIONS

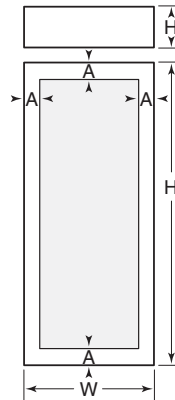

ICBWS-30 Dual Flush Inset		
DOOR	W	H
Flush Inset Panel	775 mm	1772 mm
Spacer Panel	740 mm	1751 mm
Backer Panel	756 mm	1767 mm
GRILLE	W	H
Flush Inset Panel	775 mm	235 mm
Spacer Panel	740 mm	211 mm
Backer Panel	756 mm	227 mm
WINDOW	W	H
Cut-Out	584 mm	1581 mm
Location		A 95 mm

Grille panel dimensions listed are for a standard 2134 mm overall height of the unit. For a 2108 mm overall height, subtract 25 mm from grille panel height dimensions. For a 2235 mm overall height, add 102 mm to height dimensions. Width dimensions do not vary.

Model ICBWS-30

DUAL FLUSH INSET PANELS

When installing two models ICBWS-30 or a model ICBWS-30 and built-in unit side by side in a flush inset application, you must decrease the width of the decorative flush inset panels by 13 mm. Adjustments to the panel offsets will also need to be made. These adjustments are needed to achieve a proper fit and to ensure the panels do not collide when closing. Panel dimensions in the chart below have been adjusted to reflect the decrease in panel dimensions.

IMPORTANT NOTE: If a filler strip is not used, dual installations can only be accomplished using two units with opposite hinges.

Illustrations A–E provide panel offsets and reveals for model ICBWS-30 in a flush inset application. Refer to the chart below for reference to the illustrations. All reveals are 13 mm unless otherwise specified.

For additional information on panel reveals, visit the specification library section of our website, subzerotrade.com.

⚠ CAUTION

Do not exceed the flush inset decorative panel dimensions. Exceeding dimensions could cause damage to the panels and the Sub-Zero unit.

Panel Offsets	Illus.
MODEL ICBWS-30	
Doors (hinge) / Grille Sides	A
Doors (handle) Sides	B
Grille Top	C
Grille Bottom / Door Top	D
Door Bottom	E

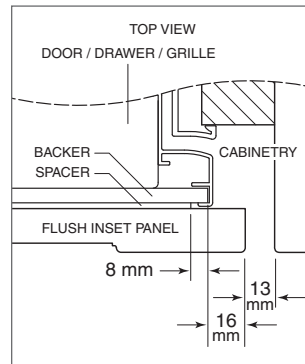

Illus. A

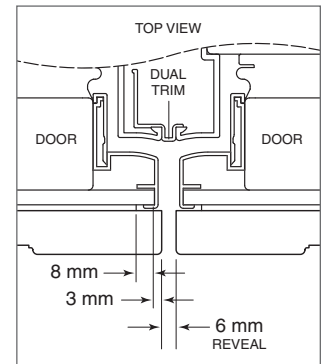

Illus. B

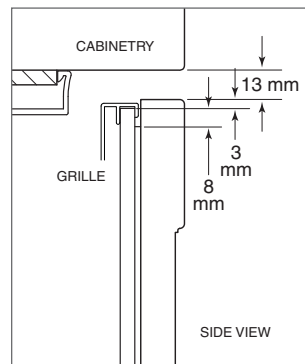

Illus. C

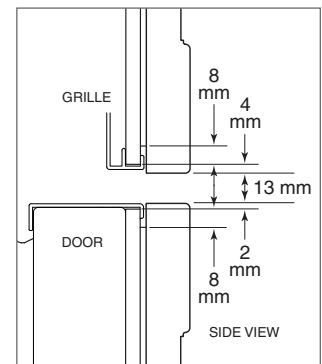

Illus. D



Illus. E

Side Panels

MODEL ICBWS-30

When planning for side panels with the installation of the model ICBWS-30, you need to be aware of the space configuration to achieve a pleasing fit. Depending on the exact panel you are using, the height of the panel may vary.

IMPORTANT NOTE: The use of side panels may change the width of your rough opening.

When installing a model ICBWS-30 with a custom side panel, an accessory kit (7003407) is required. Stainless steel side panels are also available through your authorized Sub-Zero dealer.

The side panel will need to be a minimum of 610 mm deep and 13 mm thick. Refer to the illustrations below for side panel dimensions. Routing will be necessary so that the side panel fits flush against the side of the unit.

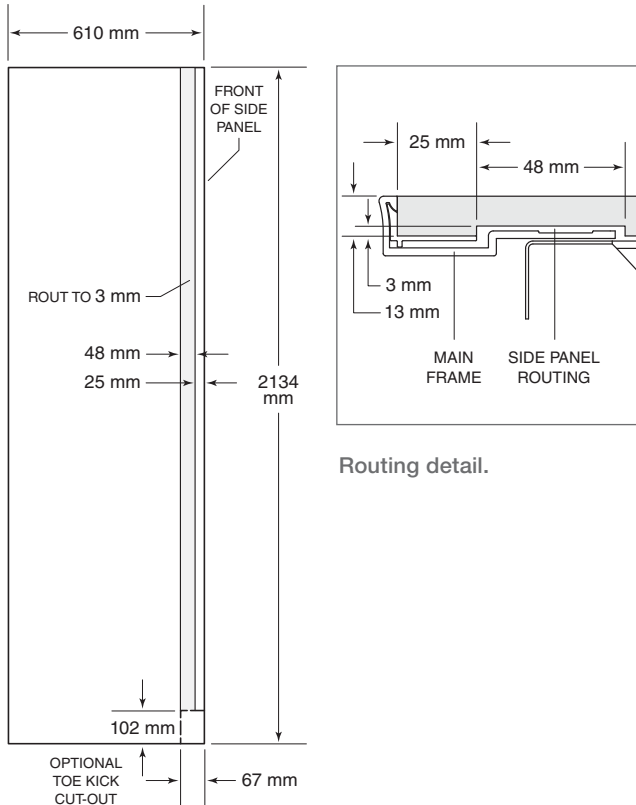

Side panel dimensions.

Handle Hardware

For overlay and integrated models, handle hardware must be provided. Optional stainless steel tubular and pro handles are available through your authorized Sub-Zero dealer.

The door frame has numerous mounting holes on each side to accommodate handle hardware. Using the pre-drilled holes to attach the handle will provide the best alignment and strength.

IMPORTANT NOTE: Refer to the full-scale template at the end of this section for a profile of the door frame and position of the glass. Do not drill through the glass.

Accessories

These optional accessories are available through your authorized Sub-Zero dealer. For local dealer information, visit the find a showroom section of our website, subzero.com.

- Front panels in stainless steel with handle options.
- Grilles for a 2108 mm or 2235 mm finished height for model ICBWS-30.
- Side panels in stainless steel and white enamel for model ICBWS-30.
- Tubular and pro handles to match the style of Wolf ovens and ranges.
- Door lock kits.
- Dual installation kits.
- Harness kit for Star-K compliance.

STANDARD HANDLE LENGTHS

Refer to the chart below for standard lengths of tubular and pro handles used on wine storage models.

Standard Handle Lengths			
ICB424G AND ICB424FS		DOOR	
Tubular Handle			584 mm
Pro Handle			533 mm
Stud Spacing			502 mm
ICB427G AND ICB427RG		DOOR	DRAWER
Tubular Handle	1053 mm		584 mm
Pro Handle	1003 mm		533 mm
Stud Spacing	975 mm		502 mm
ICBWS-30		DOOR	
Tubular Handle			1622 mm
Pro Handle			1146 mm
Stud Spacing			1114 mm

Door Frame Profile

FULL-SCALE TEMPLATE

The full-scale template below shows an example of the door frame profile for wine storage models and the relationship to the overlay panel (rails and stiles).

Dimension	A
ICB424G	25 mm
ICB427G and ICB427RG	22 mm
ICBWS-30	24 mm

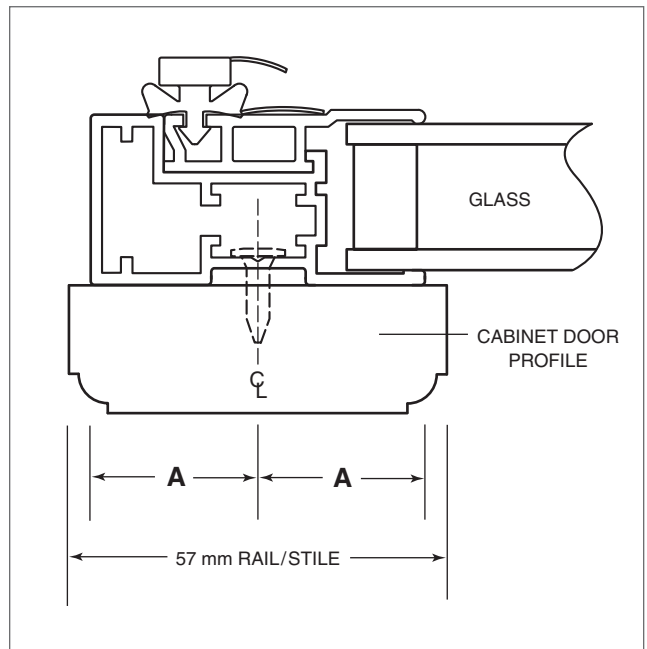

DOOR FRAME PROFILE

MODEL ICB424G SHOWN

Wine Shelf Wood Facing

FULL-SCALE TEMPLATE

For each model, the wine storage shelves have a natural cherrywood facing. You can replace these strips with wood more complementary to your design and surrounding cabinetry. Refer to the full-scale template below.

To remove the cherry strips, take the shelves out and remove the screws. Reverse the procedure to affix the new wood facing.

IMPORTANT NOTE: If you choose to stain or seal the wood facing, be aware that some of these substances are hazardous and will damage stored wine.

Dimension	A
ICB424G and ICB424FS	495 mm
ICB427G and ICB427RG	532 mm
ICBWS-30	624 mm

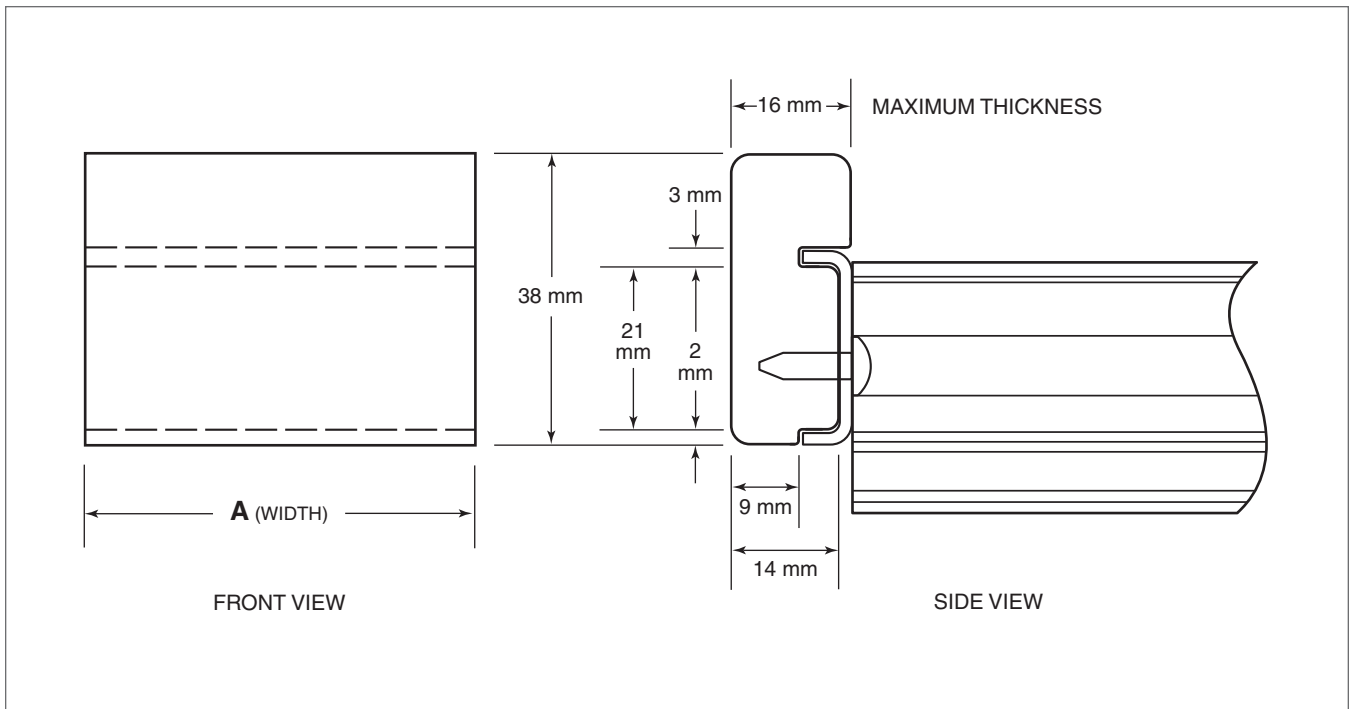

WINE SHELF WOOD FACING

WINE STORAGE MODELS

Door Clearance

FULL-SCALE TEMPLATE

Model ICB424G should extend a minimum of 6 mm beyond the front surface of adjoining cabinetry to allow for the maximum 145° door opening. The unit can be installed flush with adjacent cabinetry, however, there is potential for interference with the panel if the door is opened past 90°.

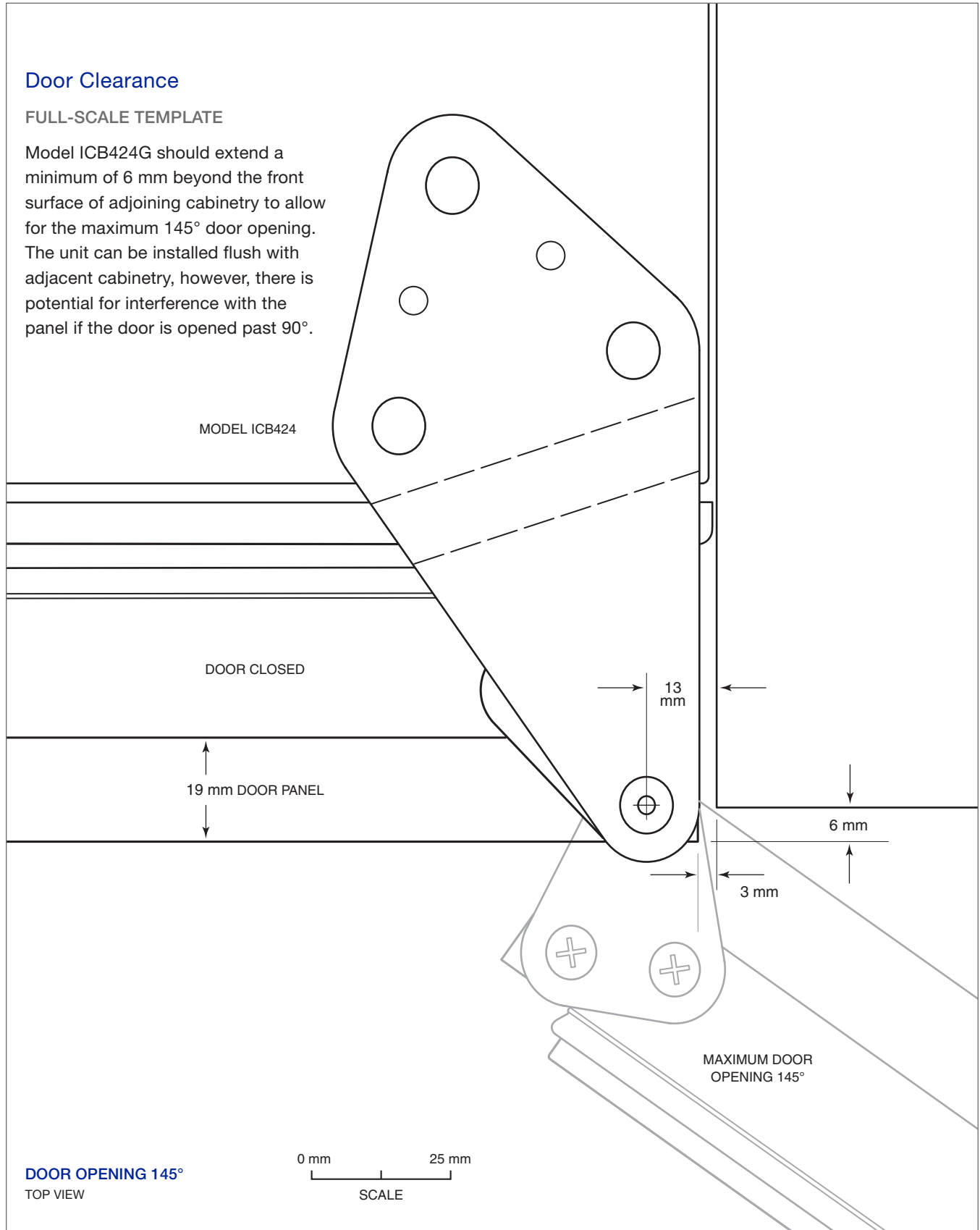

SUB-ZERO, INC.
PO BOX 44848
MADISON, WI 53744 USA
SUBZERO.COM

