

INTERNATIONAL DESIGN GUIDE

WOLF[®]

Contents

Ovens and Warming Drawers	3
Cooktops	17
Ranges and Rangetops	38
Cooktop Ventilation	57
Pro Ventilation	65
Shipping Weights	73

Features and specifications are subject to change at any time without notice. Visit wolfappliance.com/specs for the most up-to-date information.

E Series Ovens. The newest addition to the Wolf built-in oven family is a true partner, helping to create great meals with ease, as well as adding a striking design feature to the kitchen. Smart technology gives the E series 10 cooking modes, with Wolf’s innovative dual convection in single ovens and in the upper unit of double ovens. E series ovens can be installed flush with cabinets for a contemporary, integrated look.

KEY FEATURES

- Dual convection: two fans for even heat distribution.
- Ten cooking modes, including the bake stone and dehydration kits for precise, easy-to-use control.
- Full-extension bottom rack for easier access to foods.
- Balanced door hinge system for smooth opening and closing of the door.

E SERIES OVENS

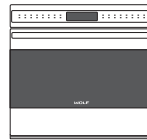

ICBSO30-2U/S-TH
UNFRAMED
TUBULAR HANDLE

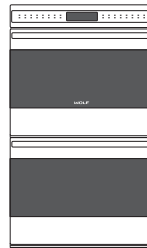

ICBDO30-2U/S-TH
UNFRAMED
TUBULAR HANDLE

E Series Ovens

762 mm SINGLE OVENS

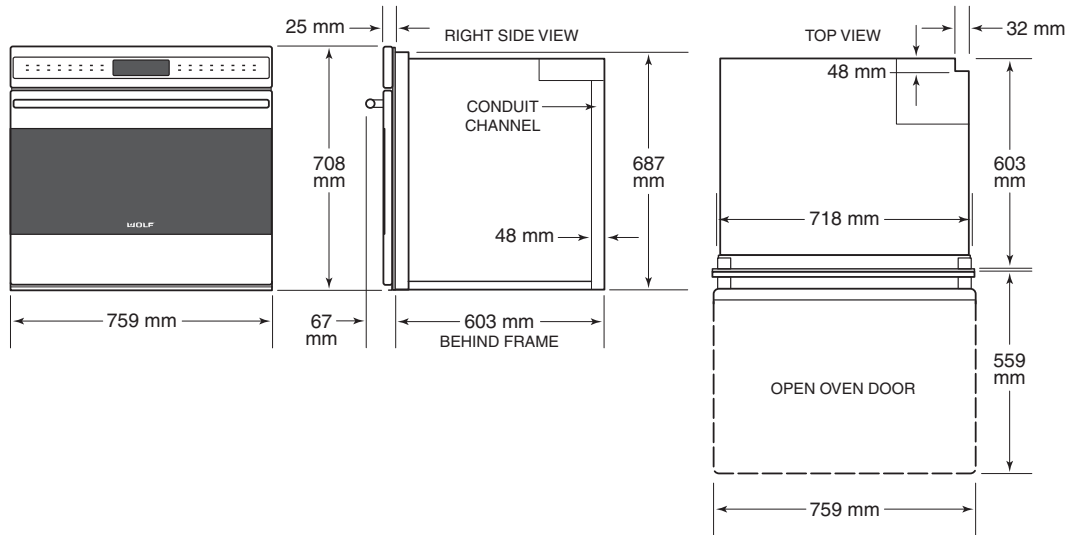

762 mm DOUBLE OVENS

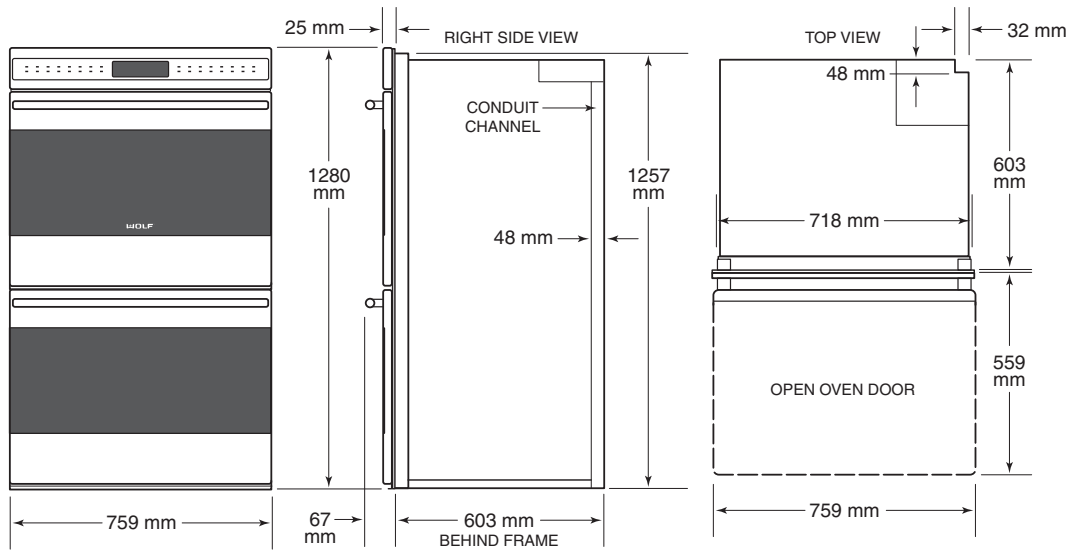

Interior Specifications				
INTERIOR CAPACITY				L
762 mm Oven				127
INTERIOR DIMENSIONS	W	H		D
762 mm Oven	635 mm	419 mm		483 mm

Planning Information

STANDARD INSTALLATION

For ease of installation, Wolf recommends using 838 mm wide cabinets with 762 mm ovens. You will need a minimum 610 mm of usable cabinet depth. The cabinet must be able to support 113 kg for a single oven and 181 kg for a double oven.

The oven has a face trim on all four sides and will overlap stiles and rails. Refer to the chart for overlap dimensions.

Oven Trim Overlap	
OVEN TRIM	E SERIES
Top Overlap	21 mm
Bottom Overlap	3 mm
Side Overlap	19 mm

FLUSH INSET INSTALLATION

A flush inset installation requires the oven to be recessed into the cabinet. A minimum 635 mm deep cabinet is needed if you want the front of the oven to be flush with surrounding cabinetry.

ELECTRICAL REQUIREMENTS

The single and double ovens require a separate, grounded 3-wire 220-240 V AC, 50/60 Hz power supply and uses the power inlet box. Refer to the illustration below. Total amps for single ovens is 21 and for double ovens, 37.

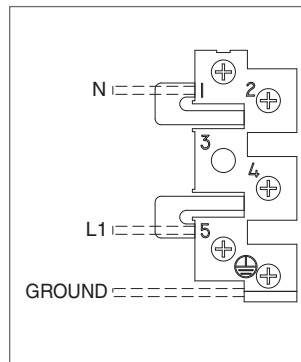

Single phase wiring diagram.

762 mm E Series Single Oven

STANDARD INSTALLATION

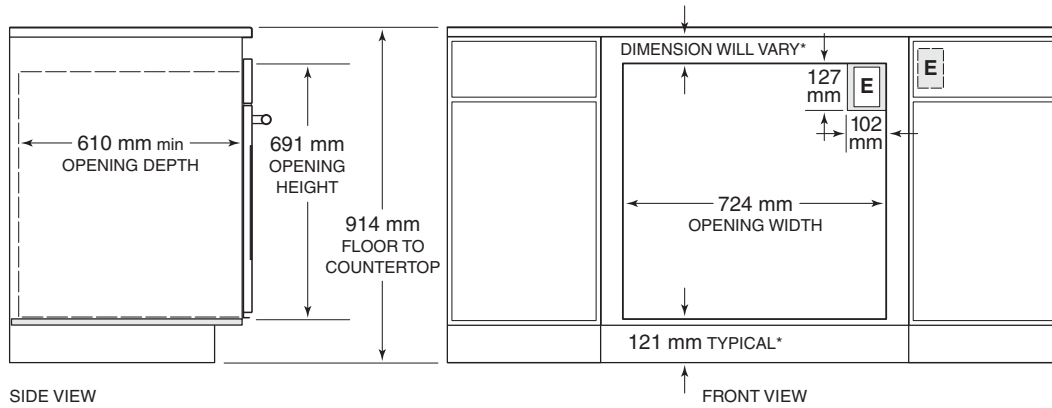

*Dimension must accommodate height of oven trim.

NOTE: Location of electrical supply within opening may require additional cabinet depth. Dashed line represents profile of unit.

762 mm E Series Double Oven

STANDARD INSTALLATION

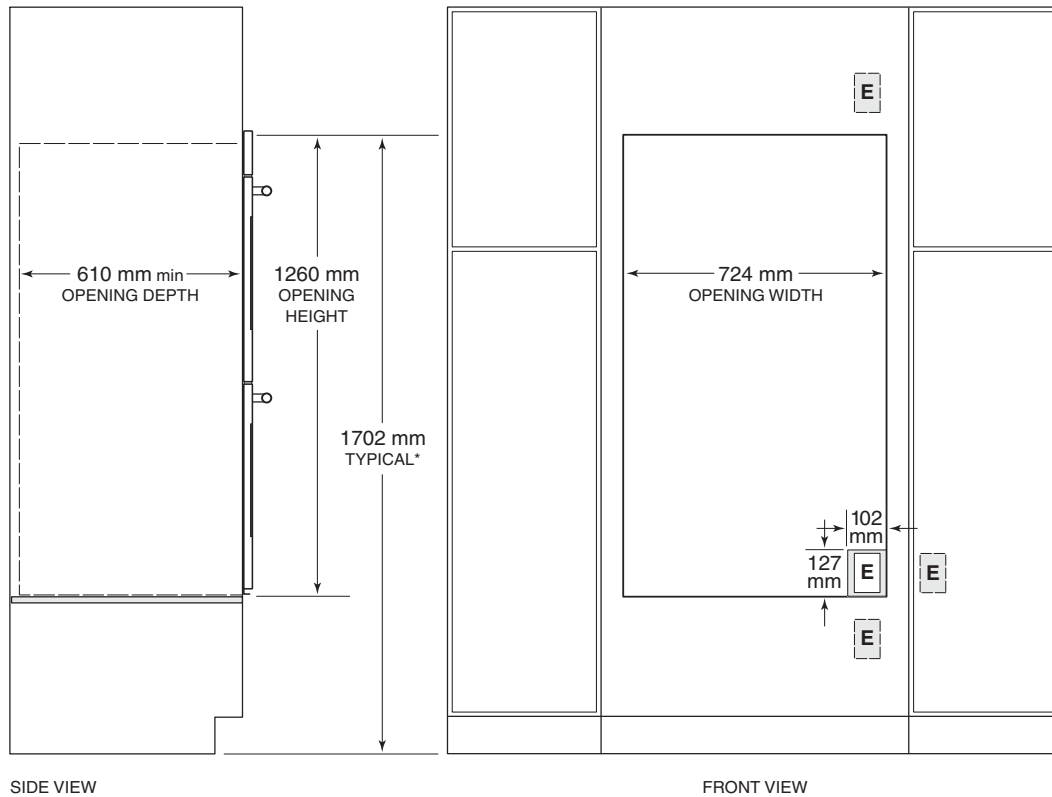

*Dimension must accommodate height of oven trim.

NOTE: Location of electrical supply within opening may require additional cabinet depth. Dashed line represents profile of unit.

762 mm E Series Single Oven

FLUSH INSET INSTALLATION

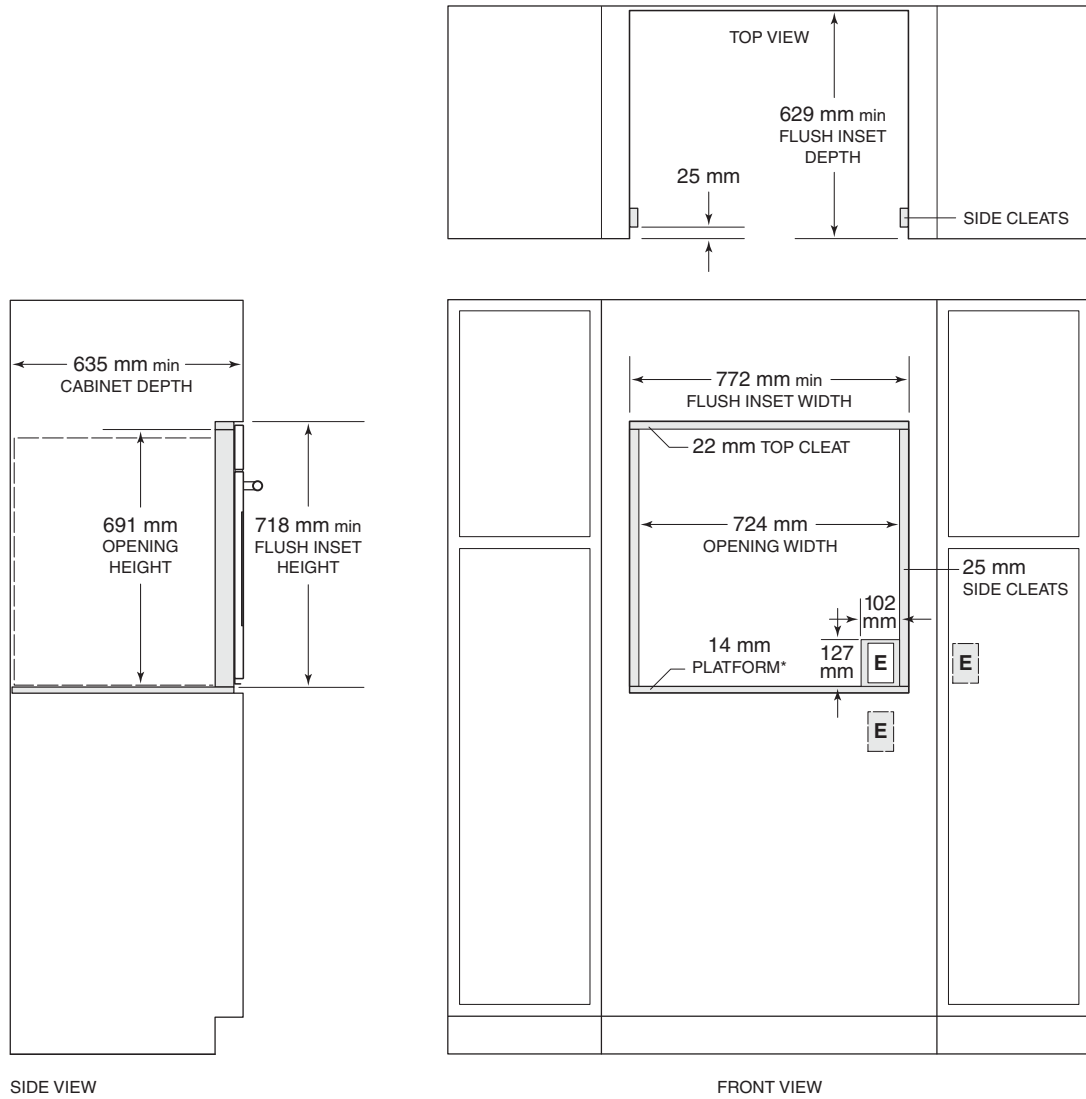

*Platform must support 113 kg.

NOTE: Location of electrical supply within opening may require additional cabinet depth. Dashed line represents profile of unit.

762 mm E Series Double Oven

FLUSH INSET INSTALLATION

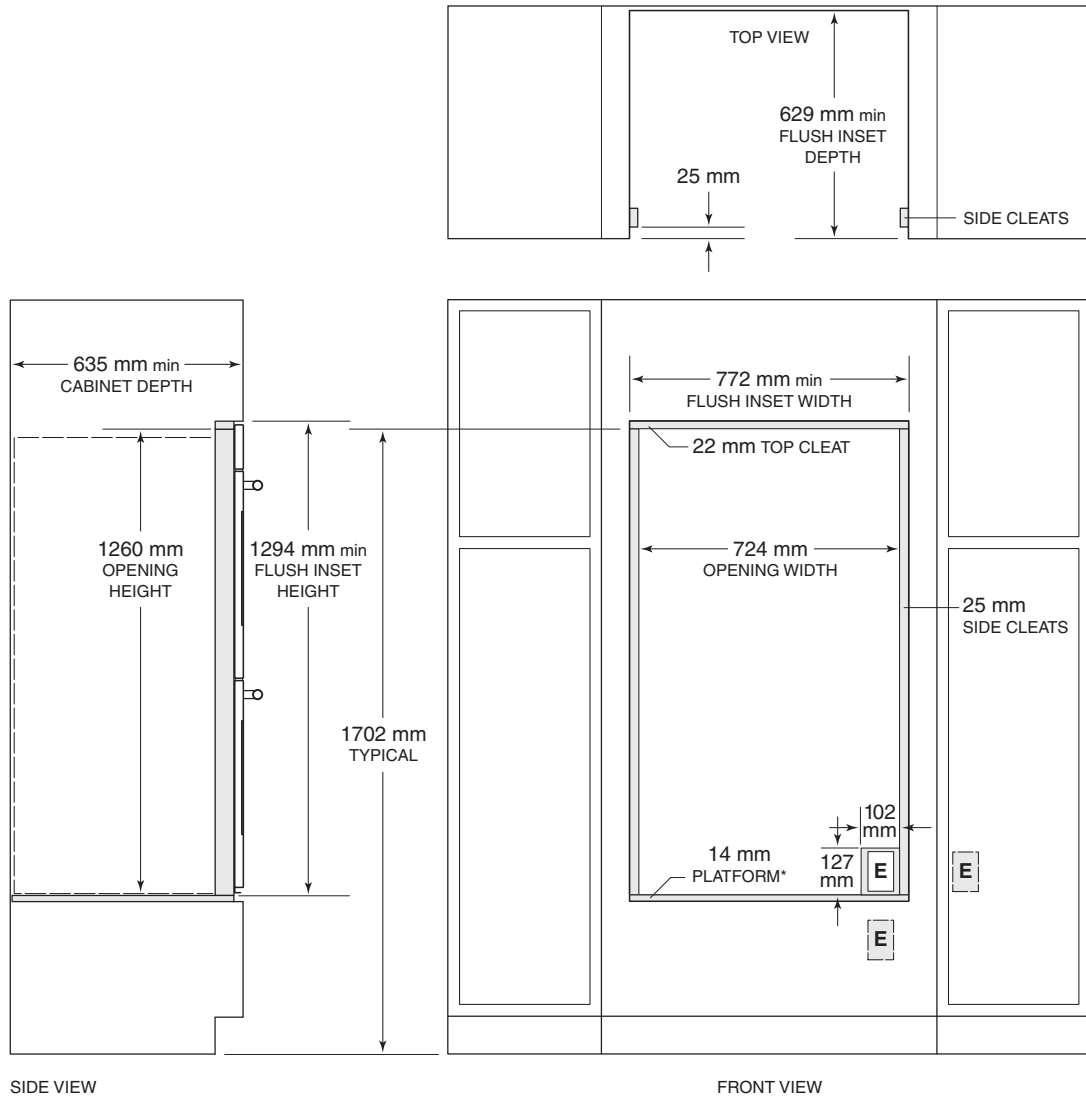

*Platform must support 181 kg.

NOTE: Location of electrical supply within opening may require additional cabinet depth. Dashed line represents profile of unit.

Microwave Ovens. Taking the experience we've gained from our microwave ovens and combining that with the expertise of convection, Wolf has brought the best of both cooking technologies together in one unit. Aside from looking beautiful whether you use it in conjunction with an oven or not, the unit offers you all the performance you expect from Wolf—a cooking company with a heritage of nearly 75 years in the kitchen.

KEY FEATURES

- Built-in convection microwave oven with 40 L capacity
- 230 V model output power—microwave 900W, grill 1300W and convection 1450W
- 240 V model output power—microwave 900W, grill 1400W and convection 1400W
- 762 mm trim allows microwave to be built in to fit above a Wolf built-in oven
- Classic stainless steel trim
- 5 auto-cook settings
- Multiple language settings
- Energy save mode
- 10 convection temperature settings
- 5 cook settings
- Removable 362 mm turntable and turntable support
- Removable low rack for broiling and removable high rack for baking
- Oven door with window
- Multiple rack baking
- Safety door latches—oven will not operate unless the door is closed
- Oven light comes on when oven is operating or door is open
- Tight door seals
- Rear ventilation openings

CONVECTION MICROWAVE WITH GRILL



ICBMW30-230



ICBMW30-240

Planning Information

Specifications on the following page provide overall dimensions, rough openings and installation options for the convection microwave oven. We have minimized the information contained in the illustrations, concentrating on the critical information you need to plan your installation.

Interior Specifications	
INTERIOR CAPACITY	L
Convection Microwave with Grill	40

ELECTRICAL REQUIREMENTS

Connect the appliance to a single phase 230-240 V/50 Hz alternating current via a correctly installed earth socket. The socket must be fused with a 16 A fuse.

Convection Microwave with Grill

OVERALL DIMENSIONS

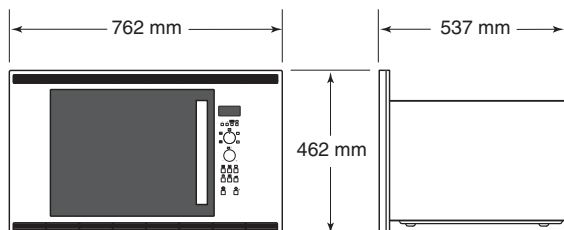

BUILT-IN INSTALLATION

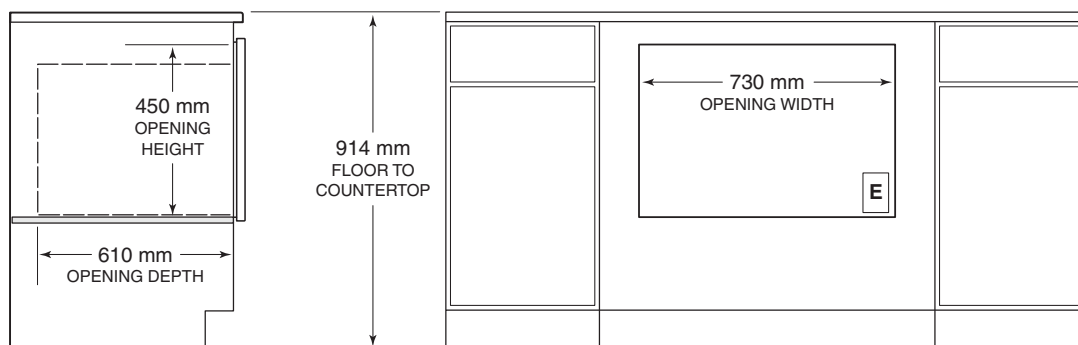

SIDE VIEW

FRONT VIEW

Dashed line represents profile of unit.

Warming Drawers. Wolf warming drawers are designed to take care of prepared foods until it's time to serve them. You can adjust the temperature, keeping moist foods moist and crisp foods crisp. Warming drawers are ideal for proofing dough. Stainless steel drawer fronts are available to match the look of Wolf E series built-in ovens and sealed burner rangetops. The integrated drawer front allows for a custom wood panel and handle. Model ICBWWD30, approved for outdoor installations, is ideal for any outdoor kitchen.

KEY FEATURES

- 850-watt heating element with temperature control range of 26°C to 93°C.
- Spacious 43.5 L interior capacity.
- Preset, four-hour automatic shutoff.
- Hidden electronic touch controls for sleek appearance.
- Ball-bearing drawer glides for smooth, full extension.
- UL approved for warming towels.
- Accessory six-piece container set available.

STAINLESS STEEL DRAWER FRONTS

E SERIES



UNFRAMED
TUBULAR HANDLE

PRO SERIES



25 mm THICK

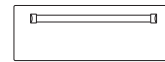

51 mm THICK



51 mm THICK
914 mm WIDE

INTEGRATED



CUSTOM PANEL

Warming Drawer Front

Wolf stainless steel and integrated drawer fronts allow for many design options, but the warming drawer itself will be the same for all applications.

When installing a Wolf warming drawer in combination with an E series built-in oven, you may choose the stainless steel drawer front to match the trim and handle of your oven. The pro series 51 mm thick drawer front with pro handle is designed to be installed below a sealed burner rangetop, so the panel aligns properly with the front of the rangetop.

Keep in mind, overall dimensions for the warming drawer remain the same, even though the drawer front may be wider to match a Wolf 914 mm wide sealed burner rangetop.

OVERALL DIMENSIONS

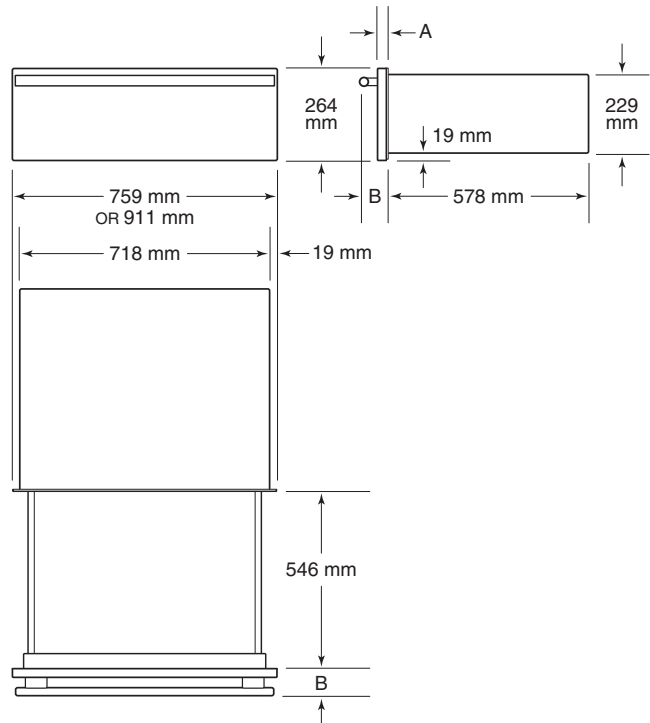

Stainless Steel Drawer Front			
E SERIES		A	B
Tubular Handle		29 mm	89 mm
PRO SERIES		A	B
25 mm Thick / Pro Handle		29 mm	89 mm
51 mm Thick / Pro Handle		54 mm	114 mm

Dimensions may vary ± 3 mm.

Integrated Drawer Front			
CUSTOM PANEL	W	H	D
Typical	759 mm	264 mm	19 mm
Minimum	746 mm	254 mm	19 mm
RECESS			
Overlay*			5 mm
Flush Inset	thickness of custom panel + 5 mm		

*Cabinet face may need to be recessed to conceal warming drawer face frame.

Planning Information

The warming drawer must be installed with a Wolf stainless steel or integrated drawer front available through your Wolf dealer. For local distributor information, visit the international section of our website, wolfappliance.com. Specific installation instructions are included with the drawer front.

For all installations, the warming drawer must be fully enclosed, top and bottom.

The warming drawer platform must be able to support 91 kg. The platform must be a minimum of 25 mm above the toe kick to allow for the warming drawer trim which overlaps 16 mm on all four sides.

The warming drawer with E series or pro series 25 mm thick front panel can be installed in a standard or flush inset application. For a standard installation, the drawer front sits proud of the cabinet face frame. A flush inset installation requires the drawer front to be recessed to be flush with surrounding cabinetry. Refer to the illustrations on the following pages for minimum cabinet dimensions for your specific installation.

ELECTRICAL REQUIREMENTS

The warming drawer requires a separate, grounded 220-240 V AC, 50/60 Hz power supply. The service should have a grounded 3-prong receptacle located within reach of the power cord and flush with the back wall. Total amps for warming drawers is 12.

E Series, Pro Series or Integrated Drawer Front

STANDARD INSTALLATION

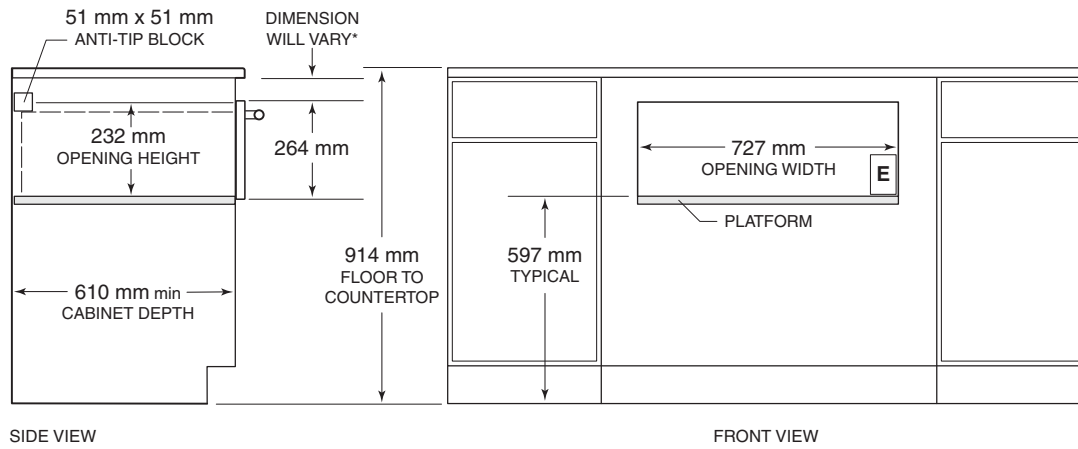

*Dimension must accommodate height of anti-tip block and drawer face overlap.

NOTE: Location of electrical supply within opening may require additional cabinet depth. Dashed line represents profile of unit.

51 mm Pro Series Drawer Front

STANDARD INSTALLATION WITH SEALED BURNER RANGETOP

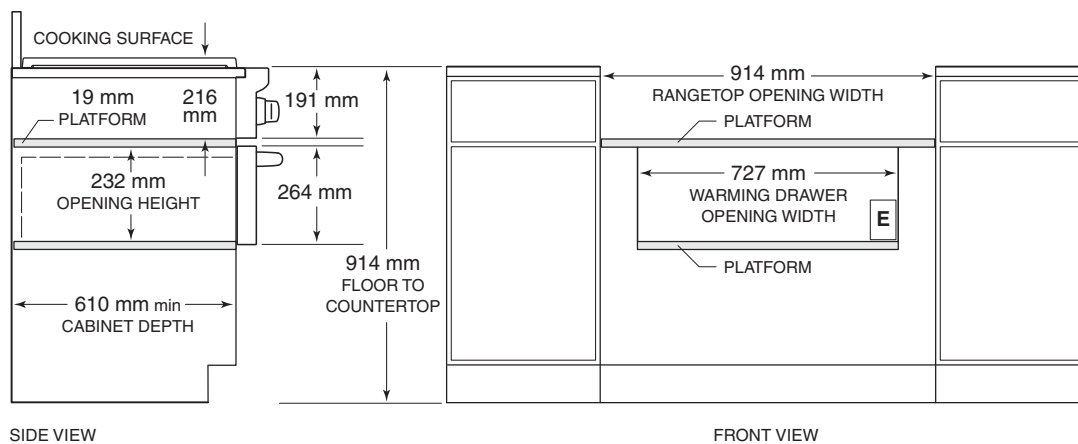

NOTE: Location of electrical supply within opening may require additional cabinet depth. Dashed line represents profile of unit.

E Series, Pro Series or Integrated Drawer Front

FLUSH INSET INSTALLATION

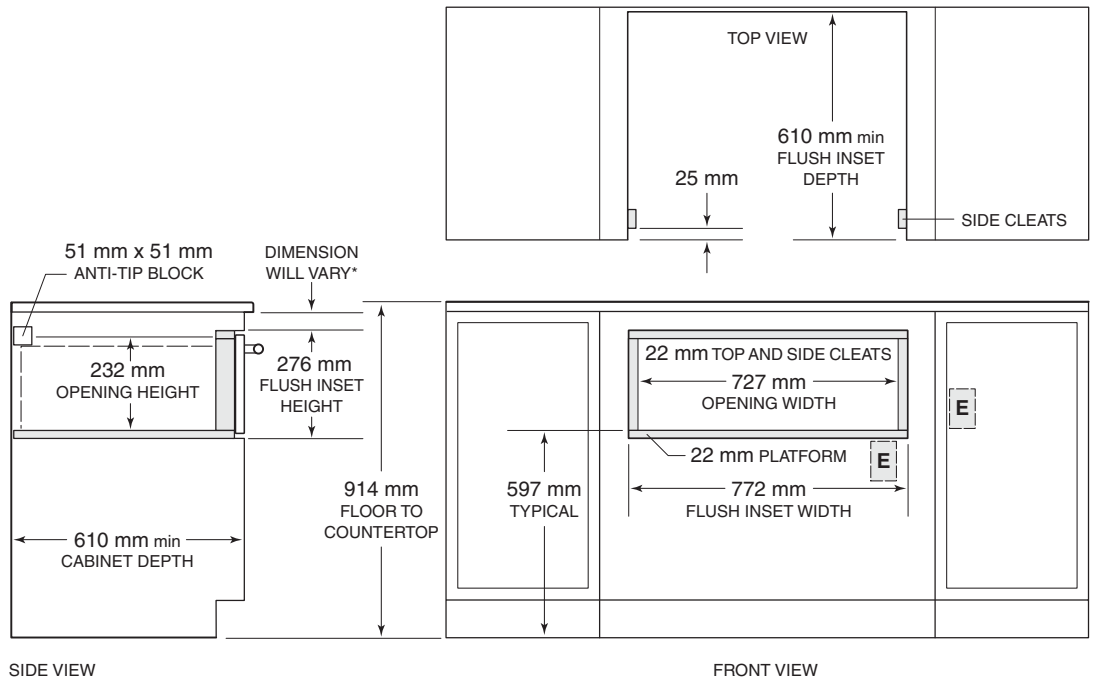

*Dimension must accommodate height of anti-tip block and drawer face overlap.

NOTE: Location of electrical supply within opening may require additional cabinet depth. Dashed line represents profile of unit.

Electric Cooktops. Behind that sophisticated, minimalist exterior (available either with classic stainless steel trim or in our trimless design) there lurks a high-performance cooking instrument fairly begging to be put through its paces. All the elements feature a true simmer setting that hold sauces and stews below the boiling point. One element includes an even lower one-touch melt setting. The 762 mm and 914 mm electric cooktops are available in unframed and framed models, with the framed models offered in all three stainless steel trims. Unframed models can be mounted flush with the countertop.

KEY FEATURES

- Ceran glass-ceramic surface for scratch resistance and easy cleaning.
- True simmer on select elements prevents scorching.
- Melt setting on select elements for gentle heat.
- Dual and triple heating zones to customize heat for pans of all sizes.
- High-frequency pulsation technology for more even heating.
- Bridge-zone element to create a larger cooking area.

ELECTRIC COOKTOPS



ICBCT15E/S
381 mm FRAMED

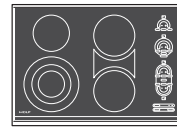

ICBCT30E/S
762 mm FRAMED

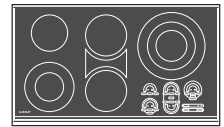

ICBCT36E/S
914 mm FRAMED



ICBCT30EU
762 mm UNFRAMED



ICBCT36EU
914 mm UNFRAMED

Electric Cooktops

381 mm FRAMED

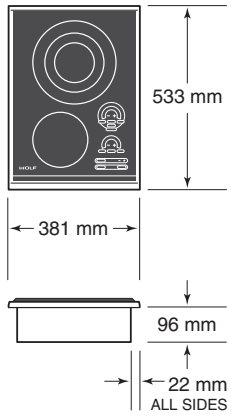

762 mm FRAMED

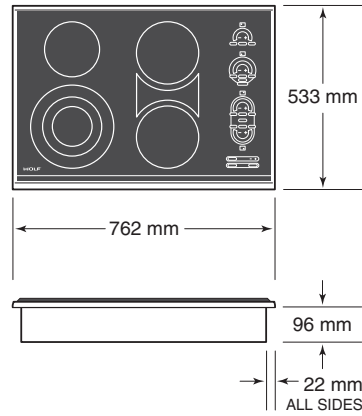

914 mm FRAMED

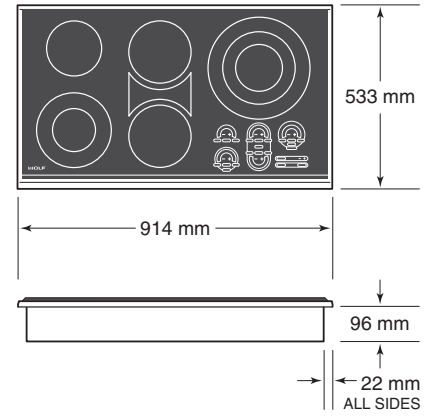

762 mm UNFRAMED

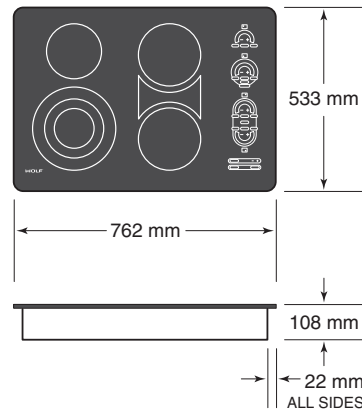

914 mm UNFRAMED

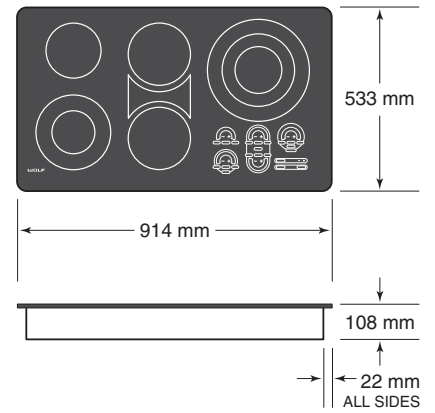

Maximum Element Power	Watts
381 mm ELECTRIC COOKTOP	
254 mm Triple	900 / 1800 / 2500
165 mm Single	1200
762 mm ELECTRIC COOKTOP	
254 mm Triple	900 / 1800 / 2500
(2) 203 mm Single	1800
165 mm Single	1200
Singles with Bridge—203 mm x 432 mm	4400
914 mm ELECTRIC COOKTOP	
305 mm Triple	1050 / 2200 / 2700
229 mm Dual	700 / 2200
(2) 203 mm Single	1800
165 mm Single	1200
Singles with Bridge—203 mm x 432 mm	4400

Planning Information

For ease of installation, Wolf recommends using 838 mm wide cabinets with 762 mm cooktops and 991 mm cabinets with 914 mm cooktops.

A minimum height clearance of 159 mm is required between countertop and any combustible surface directly below the cooktop.

Unframed electric cooktops can be mounted flush with the top of the countertop or as a frameless installation sitting on top of the countertop surface. In either installation the cooktop cut-out dimensions are the same. If the cooktop is to be mounted flush with the countertop, a recessed area surrounding the cooktop cut-out must be provided.

IMPORTANT NOTE: Flush mount installations are intended for granite, solid surface or stone countertop surfaces only.

ELECTRICAL REQUIREMENTS

Electric cooktops require a grounded 3-wire 220-240 V AC, 50/60 Hz electrical supply. Total amps for 381 mm cooktops is 16, 762 mm cooktops is 34 and 914 mm cooktops is 44.

381 mm Framed Cooktop

STANDARD INSTALLATION

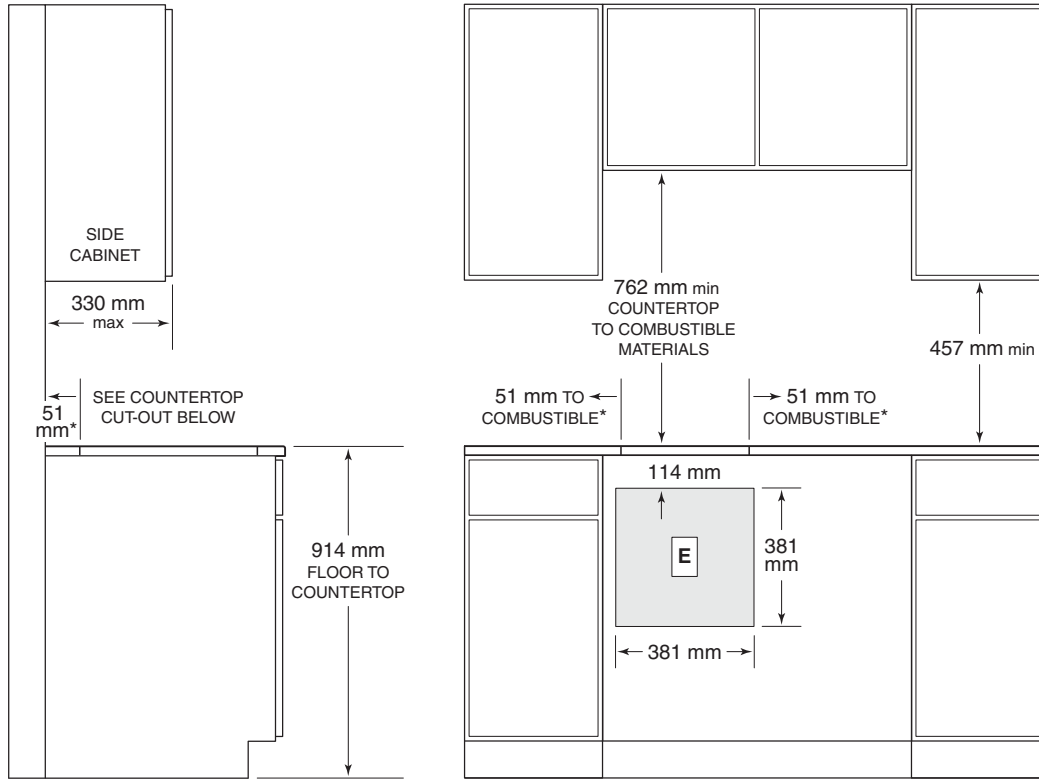

*Minimum clearance from cooktop cut-out to combustible materials up to 457 mm above countertop.

NOTE: Application shown allows for installation of two 381 mm modules side by side.

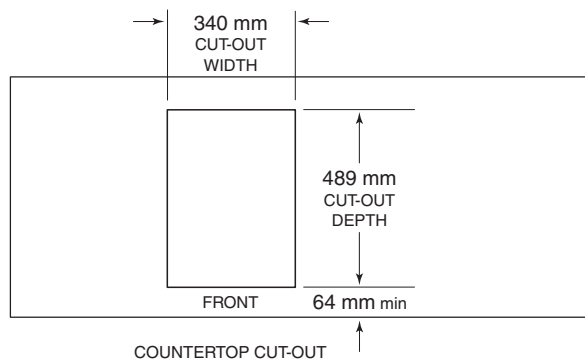

762 mm Framed Cooktop

STANDARD INSTALLATION

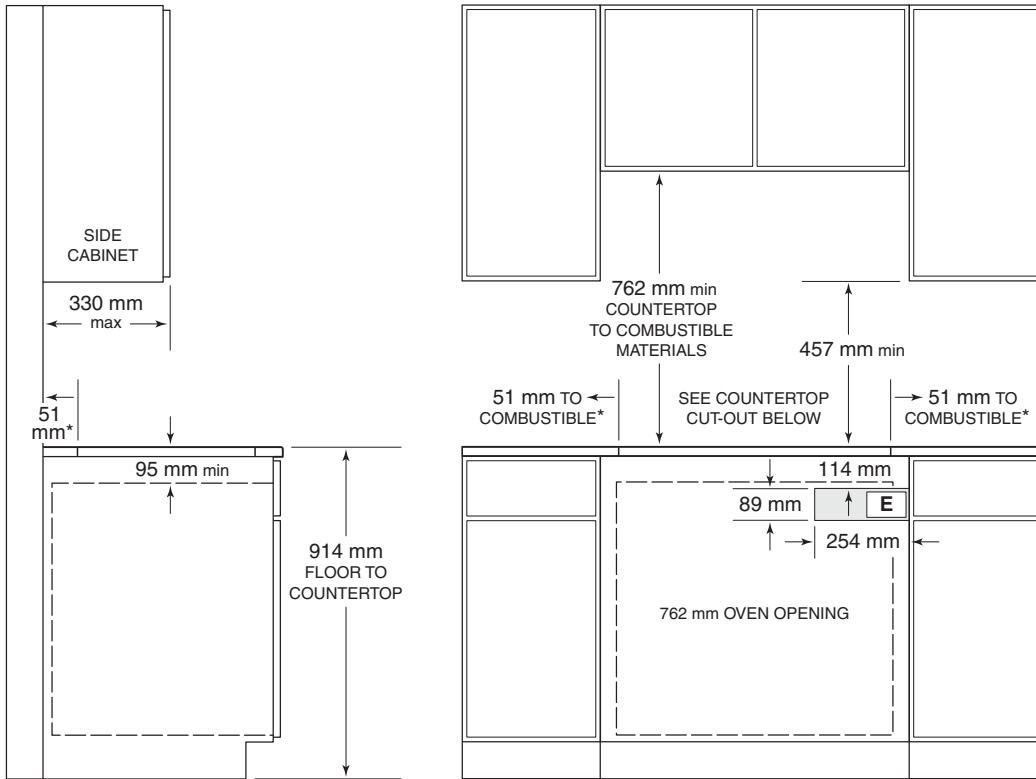

*Minimum clearance from cooktop cut-out to combustible materials up to 457 mm above countertop.

NOTE: Electrical location applies only to installation with built-in oven.

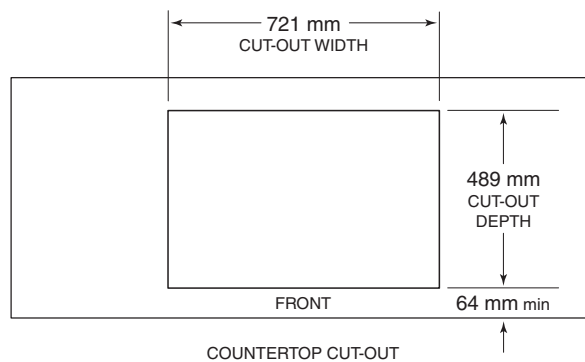

914 mm Framed Cooktop

STANDARD INSTALLATION

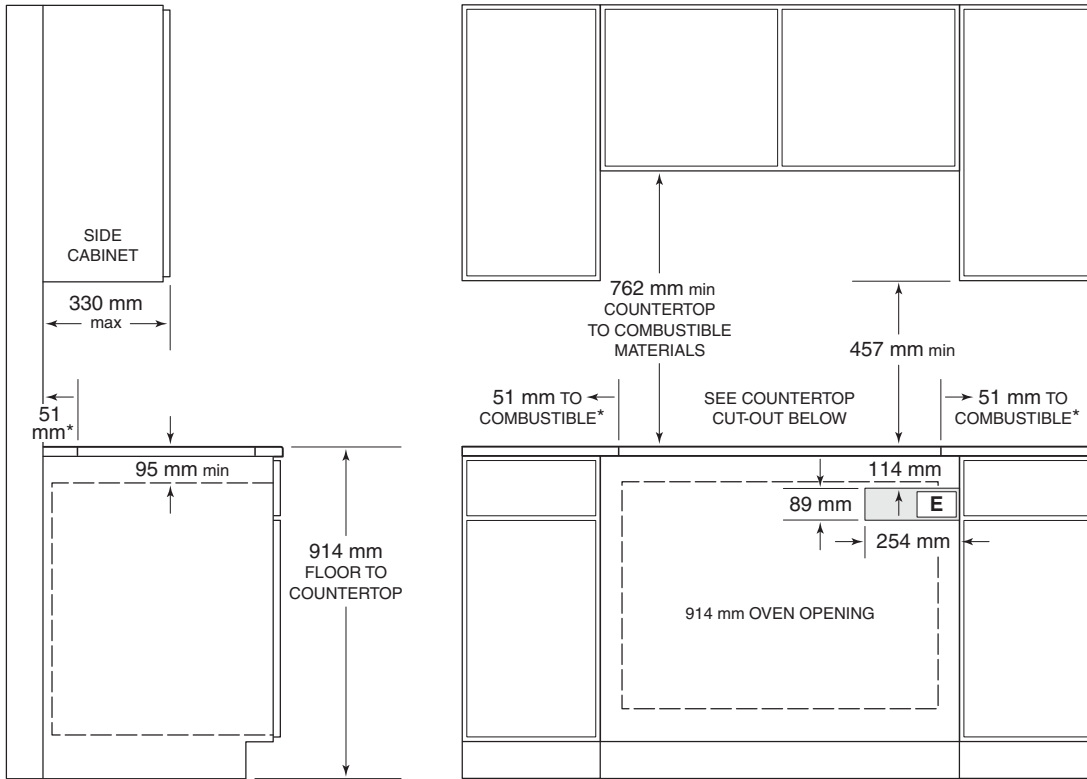

*Minimum clearance from cooktop cut-out to combustible materials up to 457 mm above countertop.

NOTE: Electrical location applies only to installation with built-in oven.

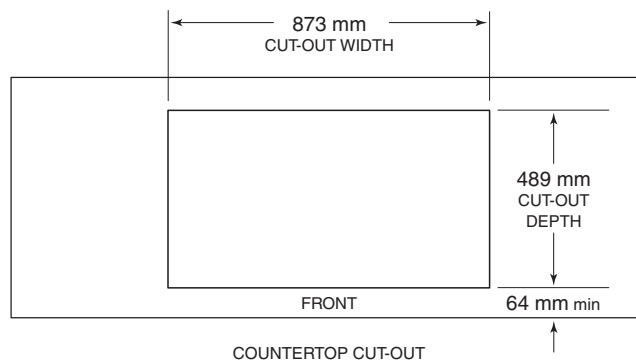

762 mm Unframed Cooktop

FLUSH INSTALLATION

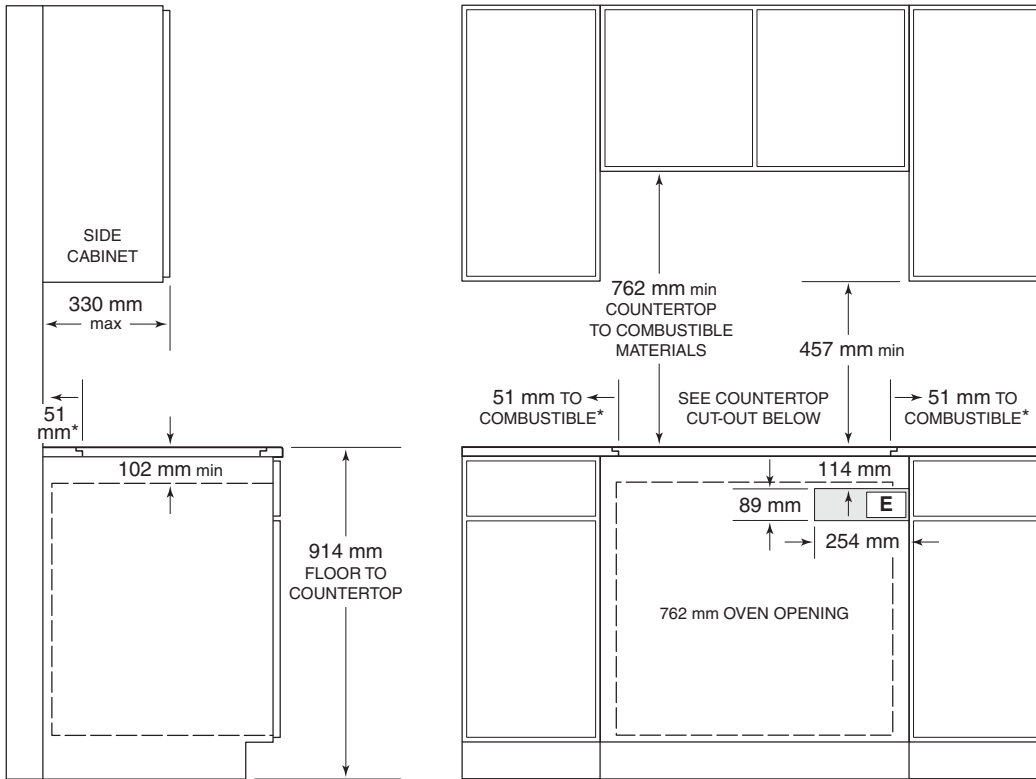

*Minimum clearance from cooktop cut-out to combustible materials up to 457 mm above countertop.

NOTE: Electrical location applies only to installation with built-in oven.

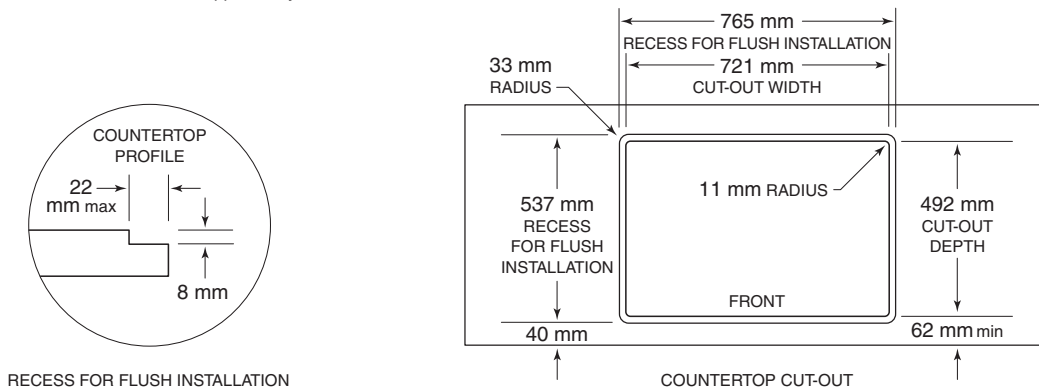

RECESS FOR FLUSH INSTALLATION

COUNTERTOP CUT-OUT

914 mm Unframed Cooktop

FLUSH INSTALLATION

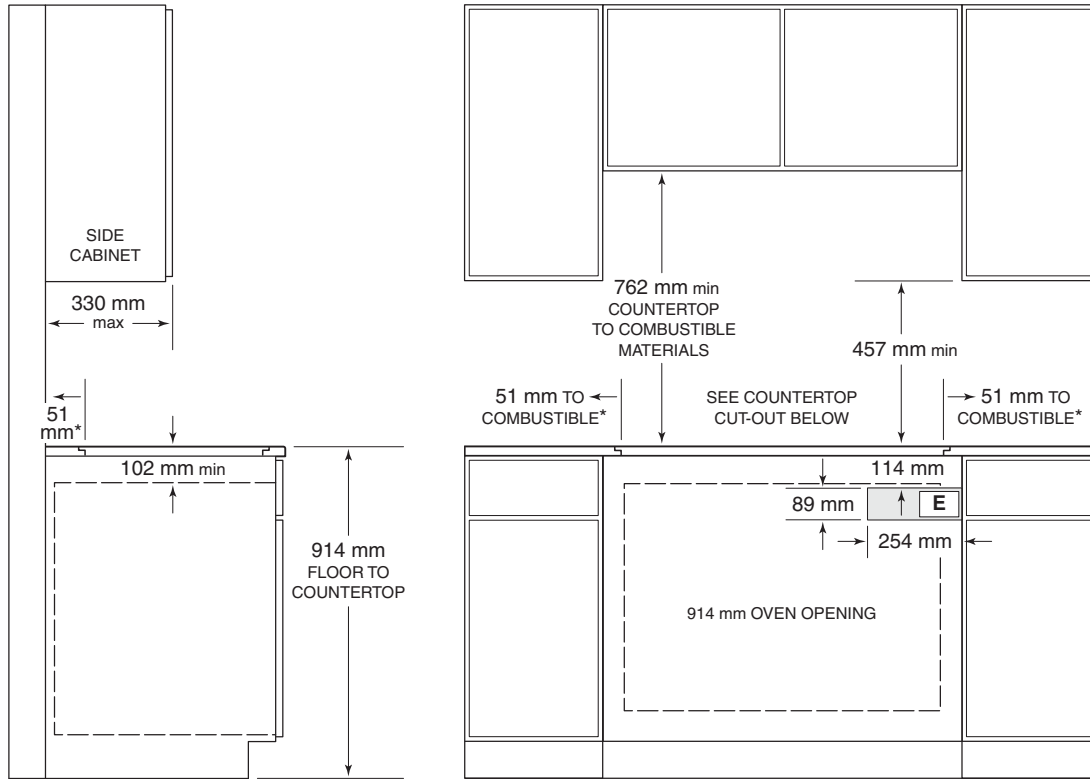

*Minimum clearance from cooktop cut-out to combustible materials up to 457 mm above countertop.

NOTE: Electrical location applies only to installation with built-in oven.

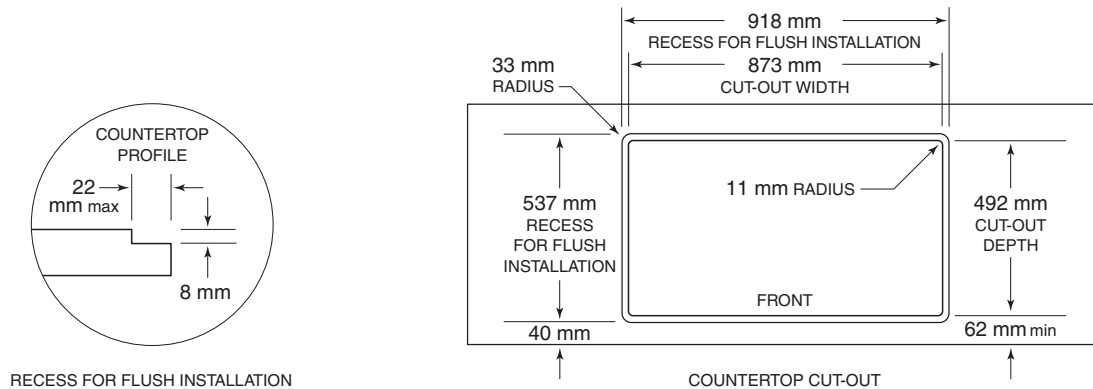

RECESS FOR FLUSH INSTALLATION

COUNTERTOP CUT-OUT

Gas Cooktops. Just looking at a Wolf gas cooktop can make your heart beat faster. Then, use it just once, and feel the real passion ignite. Dual-stacked, sealed burners place infinite control in your hands—from highest searing heat to the merest breath of flame. This latter precision feature we call true simmer. Pasta sauce or fish stew can simmer for hours without boiling or scorching. Sealed burners make splashes and spills a snap to clean up. Gas cooktops are offered in classic stainless steel. All models can be ordered as natural or LP gas.

KEY FEATURES

- Dual-stacked, sealed burners for precise control and easy cleanup.
- Flame recognition and automatic reignition for safety and ease of use.
- kW from .1 to 4.9 for tasks from melting to searing (3.8 kW on a 381 mm gas cooktop).
- True simmer setting on all burners prevents scorching.
- Illuminated, cool-to-touch knobs for user-friendly comfort.

GAS COOKTOPS

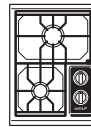

ICBCT15G/S
381 mm

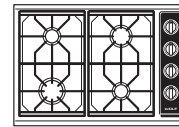

ICBCT30G/S
762 mm

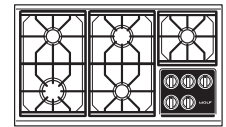

ICBCT36G/S
914 mm

Gas Cooktops

381 mm COOKTOP

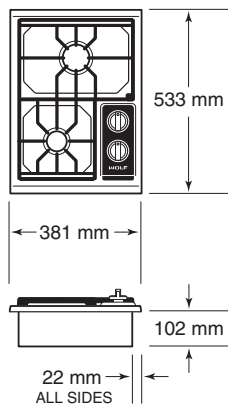

762 mm COOKTOP

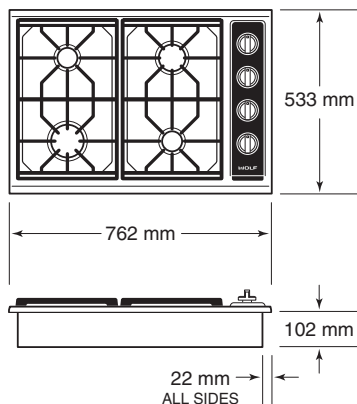

914 mm COOKTOP

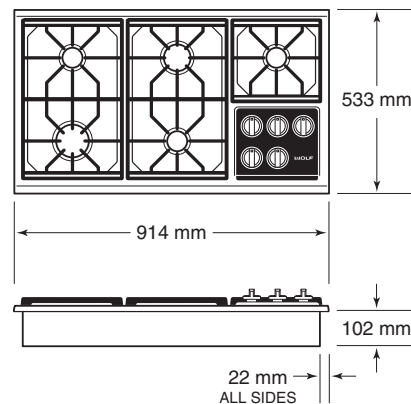

Planning Information

For ease of installation, Wolf recommends using 838 mm wide cabinets with 762 mm gas cooktops and 991 mm cabinets with 914 mm cooktops.

Burner Rating	kW	kW
381 mm GAS COOKTOP	HIGH	SIMMER
Medium	3.8	.2
Small	3.0	.1
762 mm GAS COOKTOP	HIGH	SIMMER
Large	4.9	.2
Medium	3.8	.2
(2) Small	3.0	.1
914 mm GAS COOKTOP	HIGH	SIMMER
Large	4.9	.2
Medium	3.8	.2
(3) Small	3.0	.1

ELECTRICAL AND GAS REQUIREMENTS

Gas cooktops require a separate, grounded 220-240 V AC, 50/60 Hz power supply. The service should have a grounded 3-prong receptacle located within reach of the 1.8 m power cord. Total amps for gas cooktops is less than one.

A gas supply line of 19 mm rigid pipe must be provided to the cooktop. If local codes permit, a certified, .9 m long, 13 mm or 19 mm ID flexible metal appliance connector is recommended to connect the cooktop to the gas supply line.

Wolf gas cooktops are designed to operate on natural gas at 20 mb pressure or LP gas at 37 mb pressure.

381 mm Gas Cooktop

STANDARD INSTALLATION

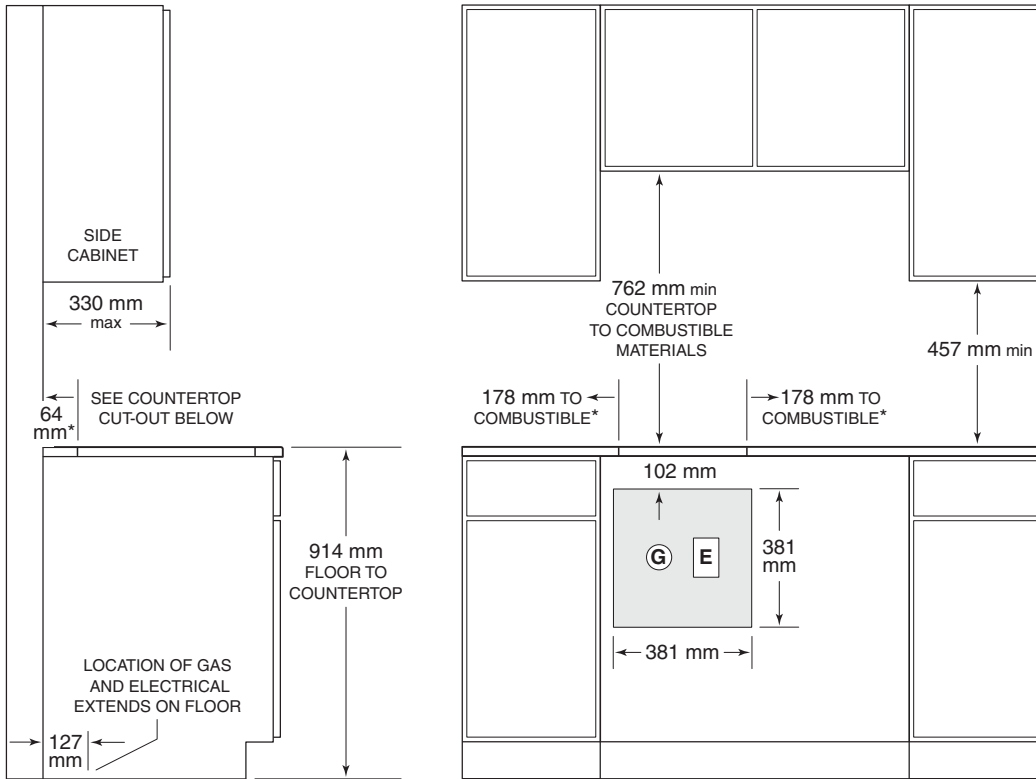

*Minimum clearance from cooktop cut-out to combustible materials up to 457 mm above countertop.

NOTE: Application shown allows for installation of two 381 mm modules side by side.

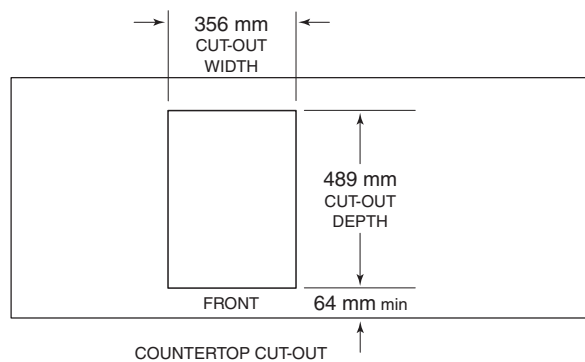

762 mm Gas Cooktop

STANDARD INSTALLATION

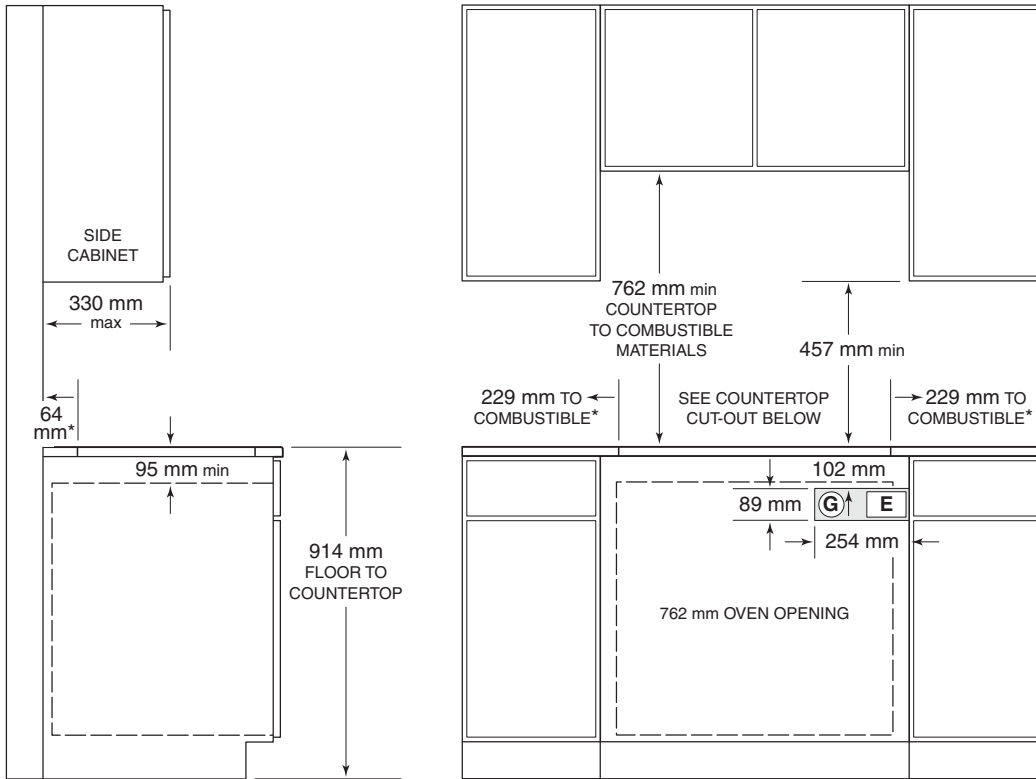

*Minimum clearance from cooktop cut-out to combustible materials up to 457 mm above countertop.

NOTE: Gas and electrical location applies only to installation with built-in oven.

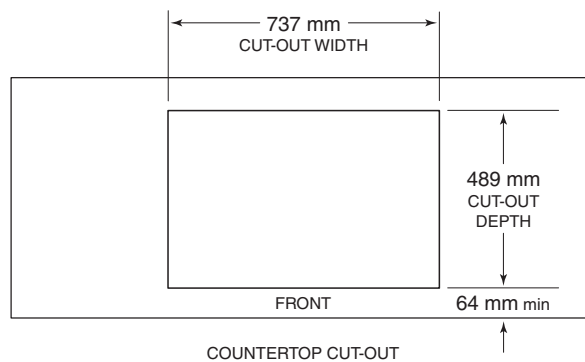

914 mm Gas Cooktop

STANDARD INSTALLATION

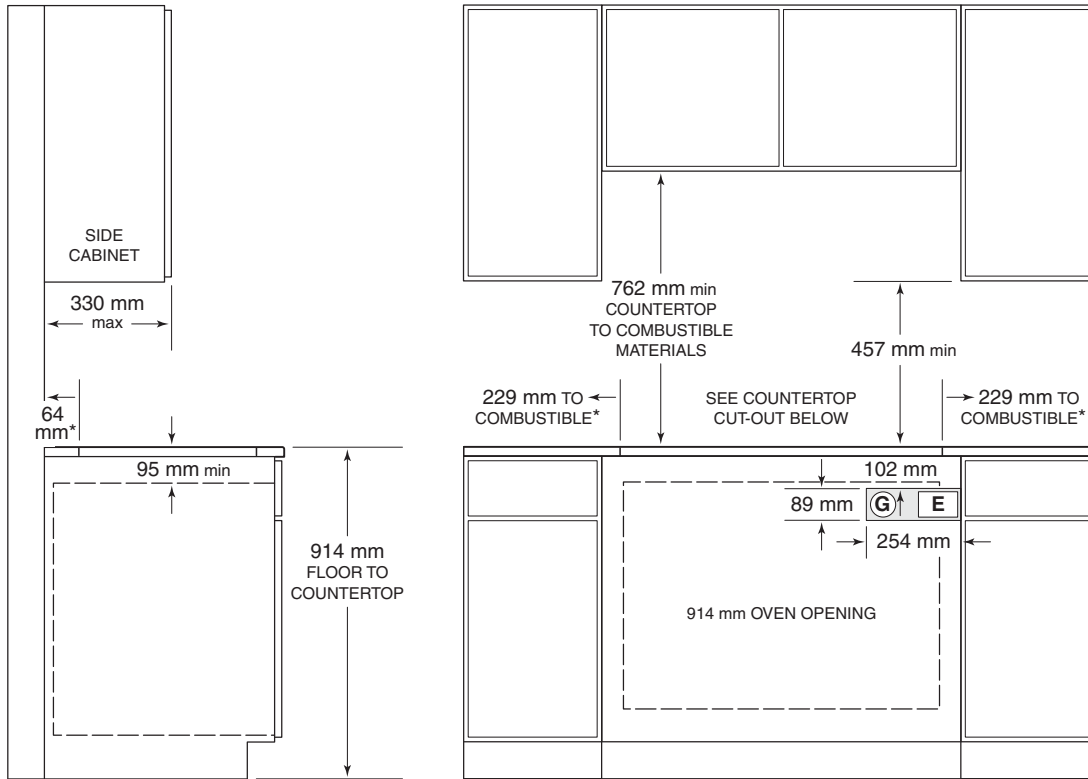

*Minimum clearance from cooktop cut-out to combustible materials up to 457 mm above countertop.

NOTE: Gas and electrical location applies only to installation with built-in oven.

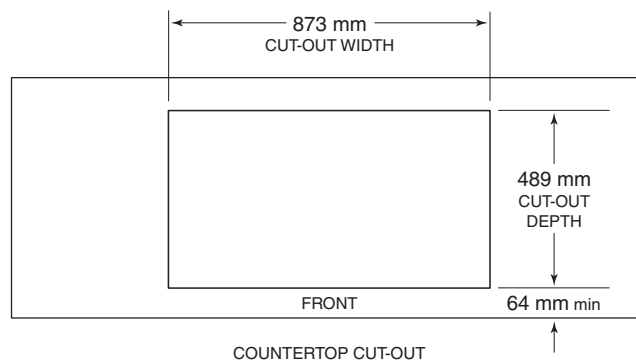

Integrated Modules. Passion for cooking reaches new dimensions with our 381 mm integrated modules. Six models cover the gamut of cooking methods, from searing to steaming to deep frying. Combine modules à la carte-style to create a truly custom cooktop. Turn any countertop into a cooking area. Even add specialty functions alongside an existing cooktop or range. Low-profile grates, dual-stacked burners, deep spill pans and illuminated controls allow these modules to integrate perfectly with their larger counterparts and deliver equal performance. All integrated modules have the classic stainless steel finish.

KEY FEATURES

- Electric cooktop: Two elements operate with high-frequency pulsation technology for consistent heating.
- Electric grill: Two 1,400-watt elements ensure precise control in front and rear zones for year-round grilling.
- Electric steamer: Powerful 2,600-watt heating element steam cooks meats, vegetables and grains beautifully.
- Electric fryer: Fried foods emerge crisp and light, due to precise control of the 2,600-watt heating element.
- Gas cooktop: Equipped with the same dual-stacked burners as our larger cooktops; .1 to 3.8 kW range.
- Multi-function cooktop: The 8.0 kW burner concentrates its flame in precisely the right spot for stir-frying.

INTEGRATED MODULES



ICBCT15E/S
ELECTRIC
COOKTOP



ICBIG15/S
ELECTRIC GRILL



ICBIS15/S
ELECTRIC
STEAMER



ICBIF15/S
ELECTRIC FRYER



ICBCT15G/S
GAS COOKTOP



ICBIM15/S
MULTI-FUNCTION
COOKTOP

Integrated Modules

ELECTRIC COOKTOP

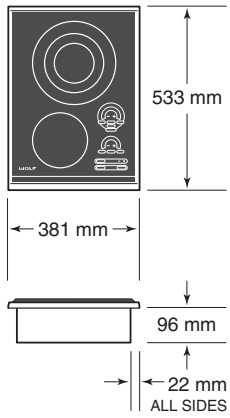

ELECTRIC GRILL

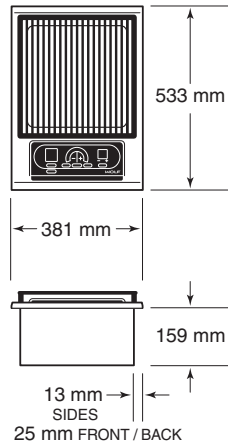

ELECTRIC STEAMER

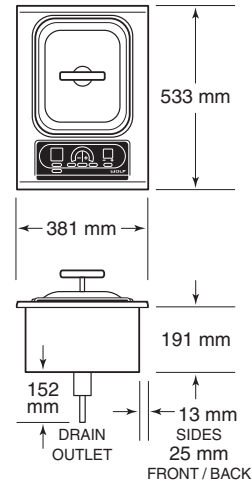

ELECTRIC FRYER

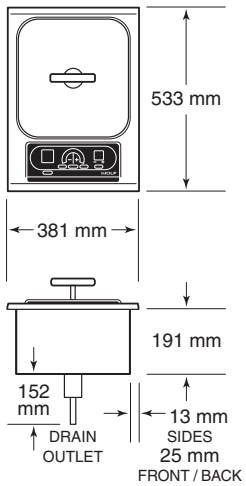

GAS COOKTOP

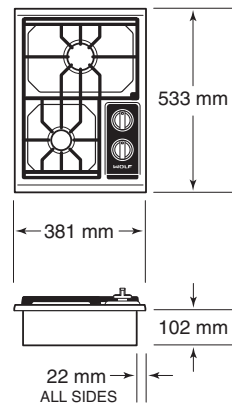

MULTI-FUNCTION COOKTOP

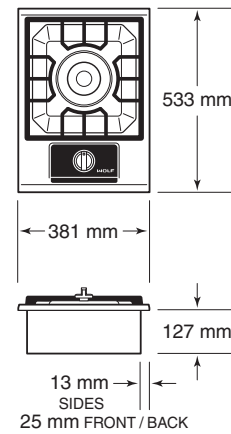

Planning Information

When multiple cooktops or modules are installed side by side, the dimensions provided in the chart are derived by adding 32 mm additional space for each additional unit, to give you the total countertop cut-out width. Dimensions include the optional filler strip available through your Wolf dealer. For local distributor information, visit the international section of our website, wolfappliance.com.

Refer to specifications on the following pages for specific installation requirements and limitations for each integrated module. Review specific installation instructions for product-to-product capabilities. Installation specifications for the electric cooktop can be found on page 20 and for the gas cooktop on page 28.

IMPORTANT NOTE: Wolf does not recommend the use of downdraft ventilation with the grill, steamer or fryer modules.

Multiple Cooktops	
COUNTERTOP CUT-OUT	WIDTH
2 Modules	743 mm
3 Modules	1130 mm
4 Modules	1518 mm
762 mm Cooktop / Module	1124 mm
762 mm Cooktop / 2 Modules	1511 mm
914 mm Cooktop / Module	1276 mm

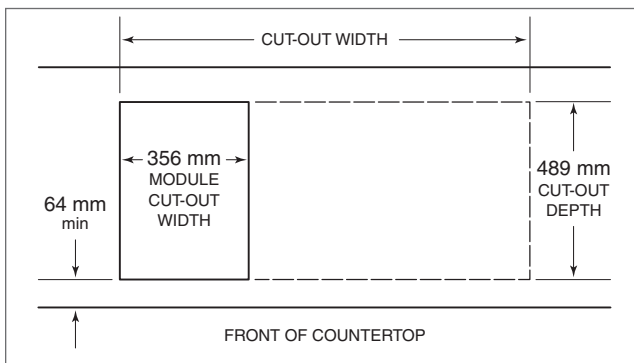

Countertop cut-out.

ELECTRICAL REQUIREMENTS

Wolf electric modules require a separate, grounded 3-wire 220-240 V AC, 50/60 Hz power supply. Gas modules require a separate, grounded 220-240 V AC, 50/60 Hz power supply and a grounded 3-prong receptacle located within reach of the 1.8 m power cord. Total amps for the electric cooktop is 16. Total amps for the electric grill, steamer and fryer is 12. Total amps for gas and multi-function cooktops is less than one.

When multiple cooktops or modules are installed side by side, each unit must have its own separate electrical supply.

GAS REQUIREMENTS

A gas supply line of 19 mm rigid pipe must be provided to the gas module. If local codes permit, a certified, .9 m long, 13 mm or 19 mm ID flexible metal appliance connector is recommended to connect the module to the gas supply line.

When multiple gas cooktops or modules are installed next to one another, they can receive their gas supply from a common line.

Wolf gas modules are designed to operate on natural gas at 20 mb pressure or LP gas at 37 mb pressure.

Electric Grill

STANDARD INSTALLATION

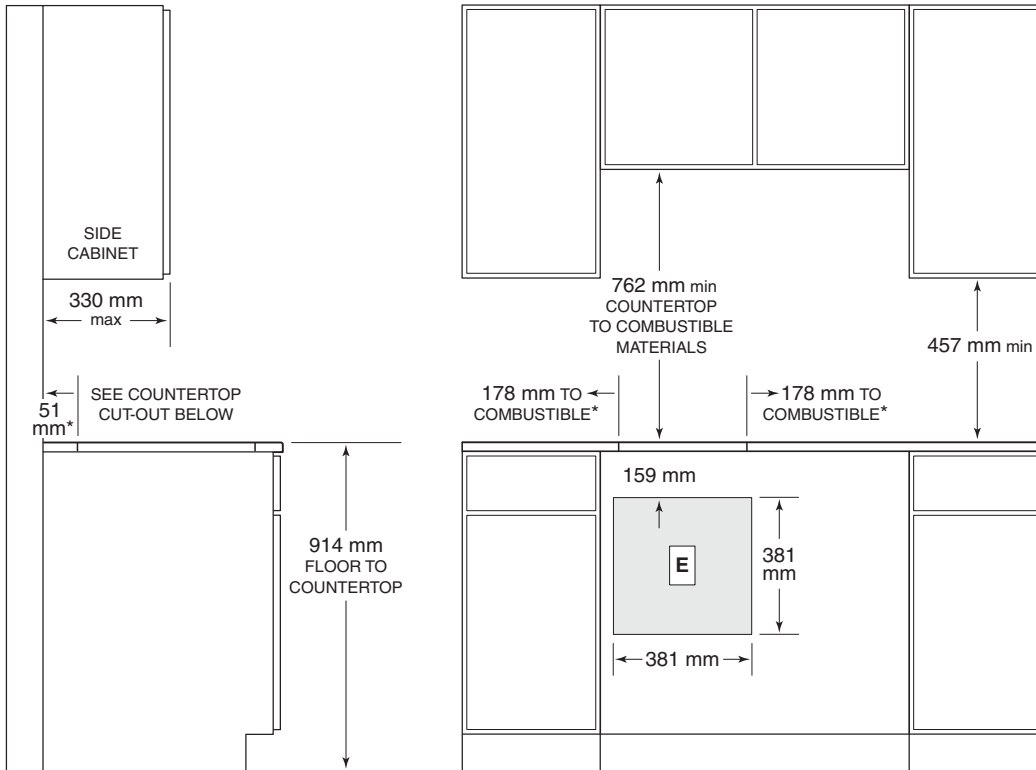

*Minimum clearance from cooktop cut-out to combustible materials up to 457 mm above countertop.

NOTE: Application shown allows for installation of two 381 mm modules side by side.

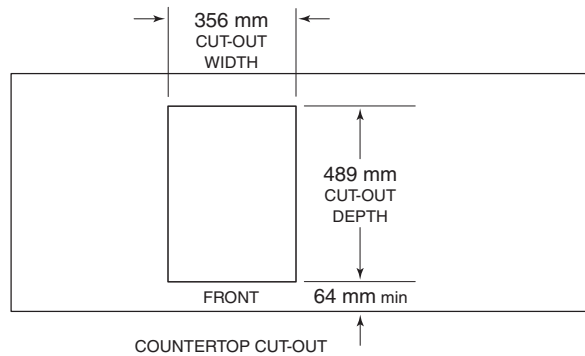

Electric Steamer

STANDARD INSTALLATION

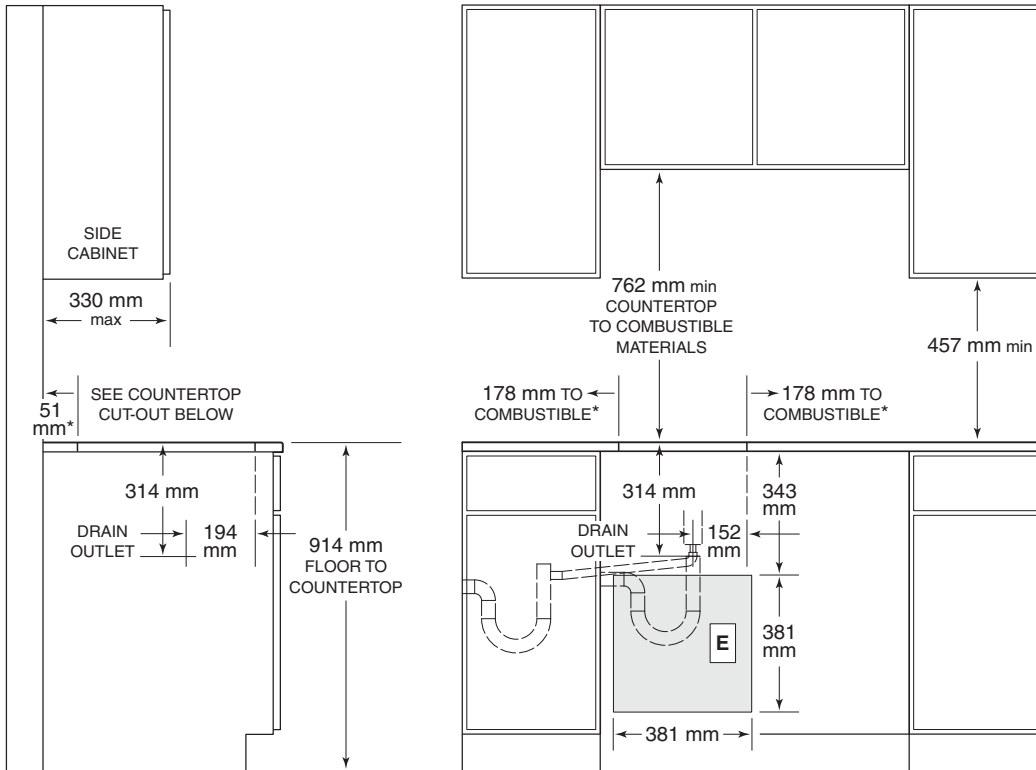

*Minimum clearance from cooktop cut-out to combustible materials up to 457 mm above countertop.

NOTE: Application shown allows for installation of two 381 mm modules side by side.

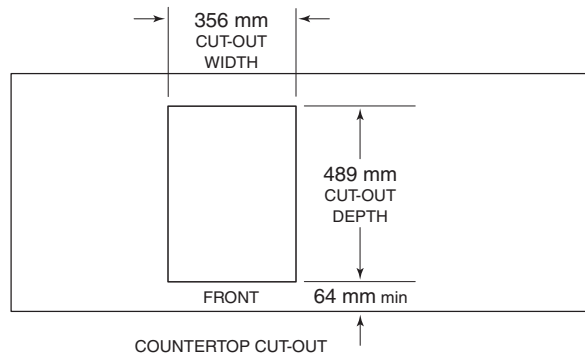

DRAIN CONNECTION OPTIONS

The 16 mm outlet from the steamer valve will accept a drain hose that must flow downward to, and tie into, an existing sink drain. A separate drain with a freefall may also be installed, or a heat-resistant receptacle may be placed under the drain outlet for drainage.

⚠ WARNING

The steamer module must be installed at least 381 mm from a Wolf fryer module. Contact between water and hot oil may cause burns from steam and hot oil.

Electric Fryer

STANDARD INSTALLATION

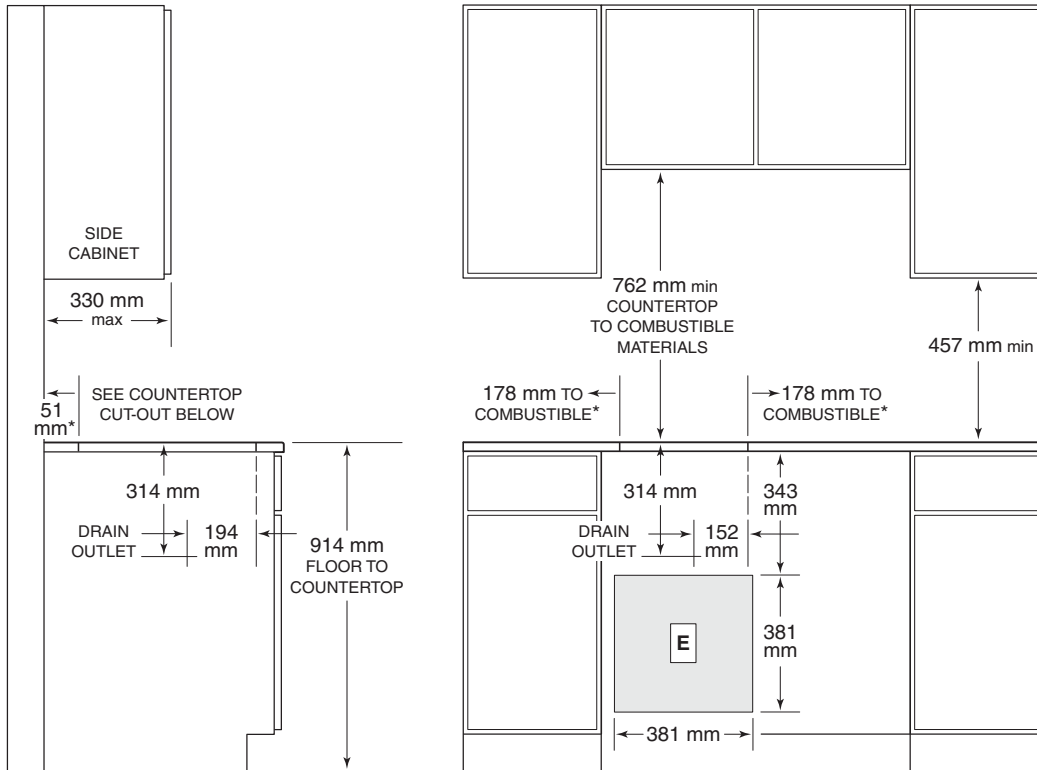

*Minimum clearance from cooktop cut-out to combustible materials up to 457 mm above countertop.

NOTE: Fryer module must be installed in base cabinet with access to valve at bottom of unit to drain oil into heat-resistant receptacle. Application shown allows for installation of two 381 mm modules side by side.

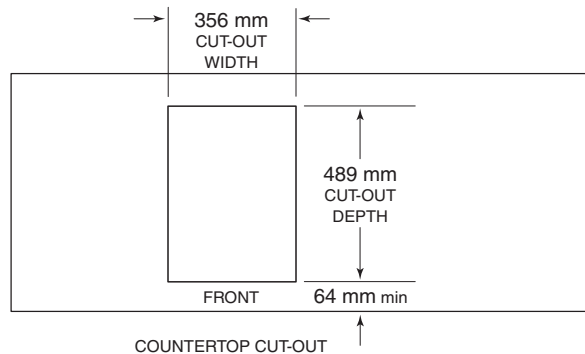

DRAIN CONNECTION

The fryer module must be installed in a base cabinet with access to the manual valve at the bottom of the unit to drain oil into a heat-resistant receptacle.

⚠ WARNING

The fryer module must be installed at least 381 mm from any open-flame cooking device or a Wolf steamer module. The open flame may cause ignition of oil, and contact between water and hot oil may cause burns.

Multi-Function Cooktop

STANDARD INSTALLATION

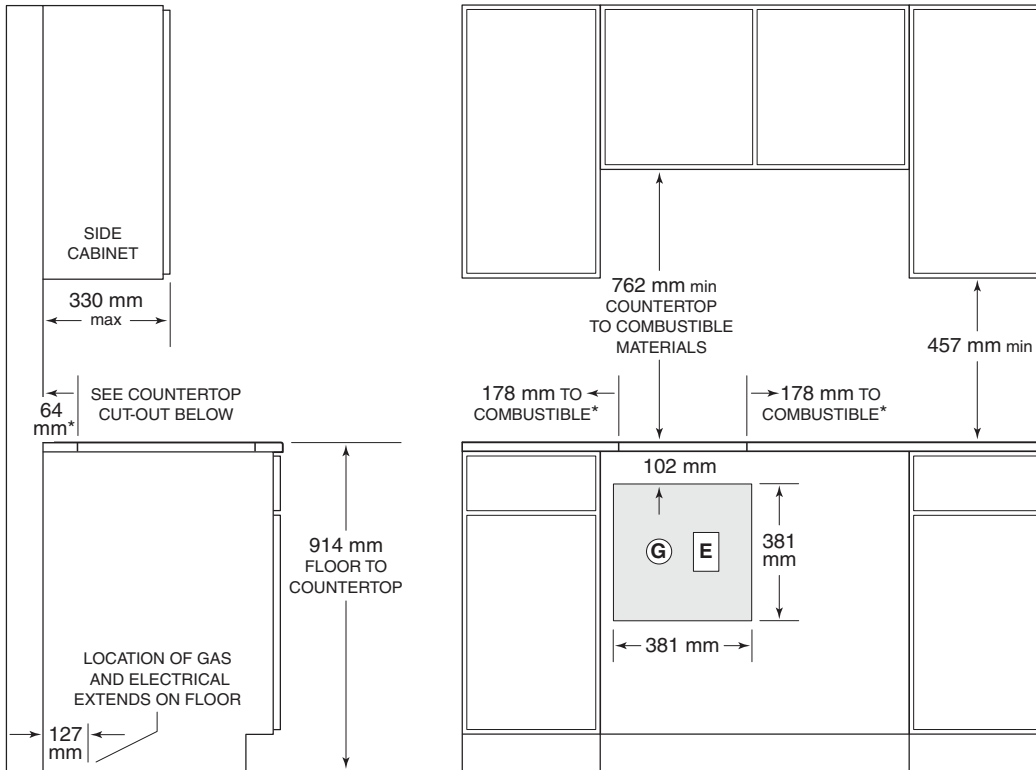

*Minimum clearance from cooktop cut-out to combustible materials up to 457 mm above countertop.

NOTE: Application shown allows for installation of two 381 mm modules side by side.

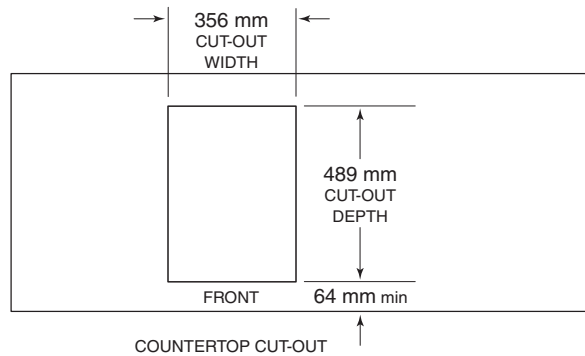

Dual Fuel Ranges. Discover a new world of cooking—the best of two worlds, actually—with a Wolf dual fuel range. Topside, gas cooking in all its glory, with the fine control of dual-stacked, sealed burners and options that include the remarkable French top. Below, that marvel of culinary technology, the Wolf convection electric oven. Its two fans and four heating elements let you select from 10 cooking modes so you can choose the one precisely suited to the dish you’re preparing. Ovens are self-cleaning. With a variety of range widths to choose from, kitchens large and small become gateways to the exciting new world of dual fuel cooking. All models have the classic stainless steel finish and can be ordered in natural or LP gas.

KEY FEATURES

- Dual-stacked, sealed burners for precise control and easy cleanup.
- Patented digital oven control knob.
- Dual convection: two fans for even heat distribution.
- Ten cooking modes, including the bake stone and dehydration kits for precise, easy-to-use control.
- Flame recognition and automatic reignition for safety and ease of use.
- Full-extension bottom rack for easier access to foods.
- Spring and damper door hinge for quiet, effortless opening and closing.

CONFIGURATIONS

914 mm

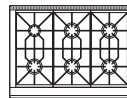

ICBDF366

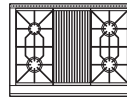

ICBDF364C

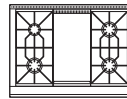

ICBDF364G

1219 mm

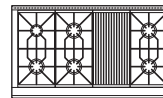

ICBDF486C

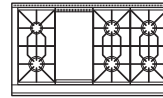

ICBDF486G

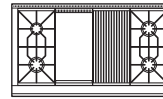

ICBDF484CG

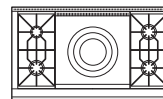

ICBDF484F

1527 mm

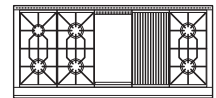

ICBDF606CG

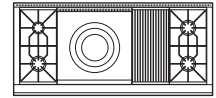

ICBDF604CF

Dual Fuel Ranges

914 mm RANGE

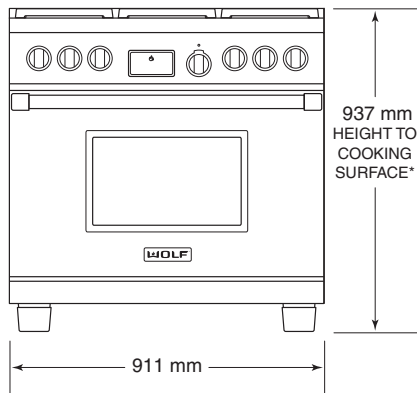

1219 mm RANGE

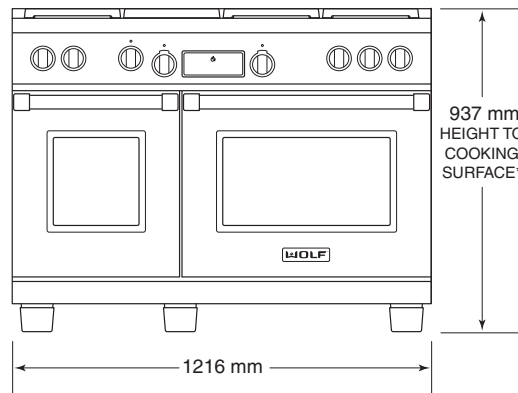

1527 mm RANGE

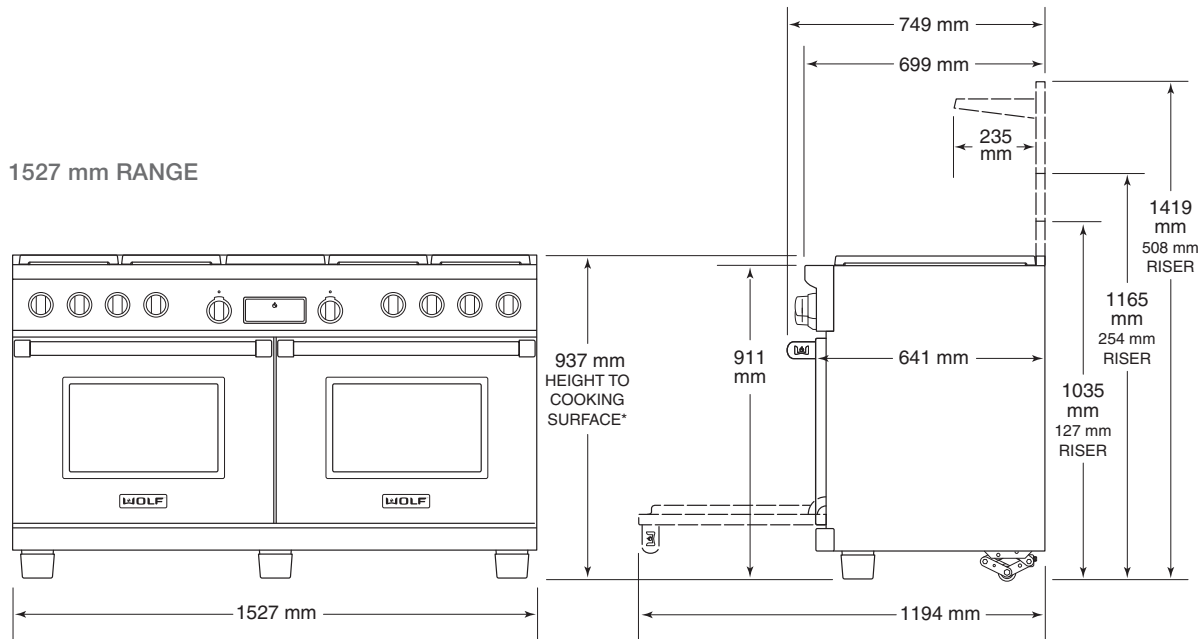

*LEGS AND CASTERS ALLOW FOR HEIGHT ADJUSTMENT UP TO 991 mm

SIDE VIEW—ALL RANGES

Planning Information

Available in three widths, Wolf dual fuel ranges are designed to fit a 914 mm, 1219 mm or 1530 mm opening.

IMPORTANT NOTE: When installing against a combustible surface, a minimum 254 mm riser is required for a 914 mm dual fuel range with charbroiler or griddle/teppan-yaki and all 1219 mm and 1524 mm models. Follow all minimum clearances to combustible surfaces shown in the installation illustrations on the following pages.

It is recommended that you use a Wolf pro ventilation hood with the dual fuel range. If the range is to be installed without ventilation, a 914 mm minimum clearance, 1118 mm for charbroiler, from countertop to combustible materials above the range is required. Refer to page 65 for pro ventilation.

ELECTRICAL AND GAS REQUIREMENTS

Wolf dual fuel ranges have a terminal block that allows for a 3-wire or 4-wire installation. A separate, grounded 220-240 V AC, 50/60 Hz electrical supply is required with its own circuit breaker. Total amps are 21 for single oven ranges and 42.5 for double oven ranges.

A gas supply line of 19 mm rigid pipe must be provided to the range. If local codes permit, a certified, .9 m long, 13 mm or 19 mm ID flexible metal appliance connector is recommended to connect the range to the gas supply line.

Wolf dual fuel ranges are designed to operate on natural gas at 20 mb pressure or LP gas at 37 mb pressure.

Oven Specifications			
INTERIOR CAPACITY			L
457 mm Oven			71
762 mm Oven			127
914 mm Oven			153
INTERIOR DIMENSIONS	W	H	D
457 mm Oven	356 mm	419 mm	483 mm
762 mm Oven	635 mm	419 mm	483 mm
914 mm Oven	762 mm	419 mm	483 mm

Burner Rating	kW	kW
SURFACE BURNERS	HIGH	SIMMER
Large	4.8	.3
(1) Small	2.7	.1
OPTIONAL FEATURES	NATURAL	LP
Infrared Charbroiler	5.6	5.15
Infrared Griddle/Teppan-Yaki	5.6	5.15
French Top	4.8	4.0

914 mm Dual Fuel Range

INSTALLATION

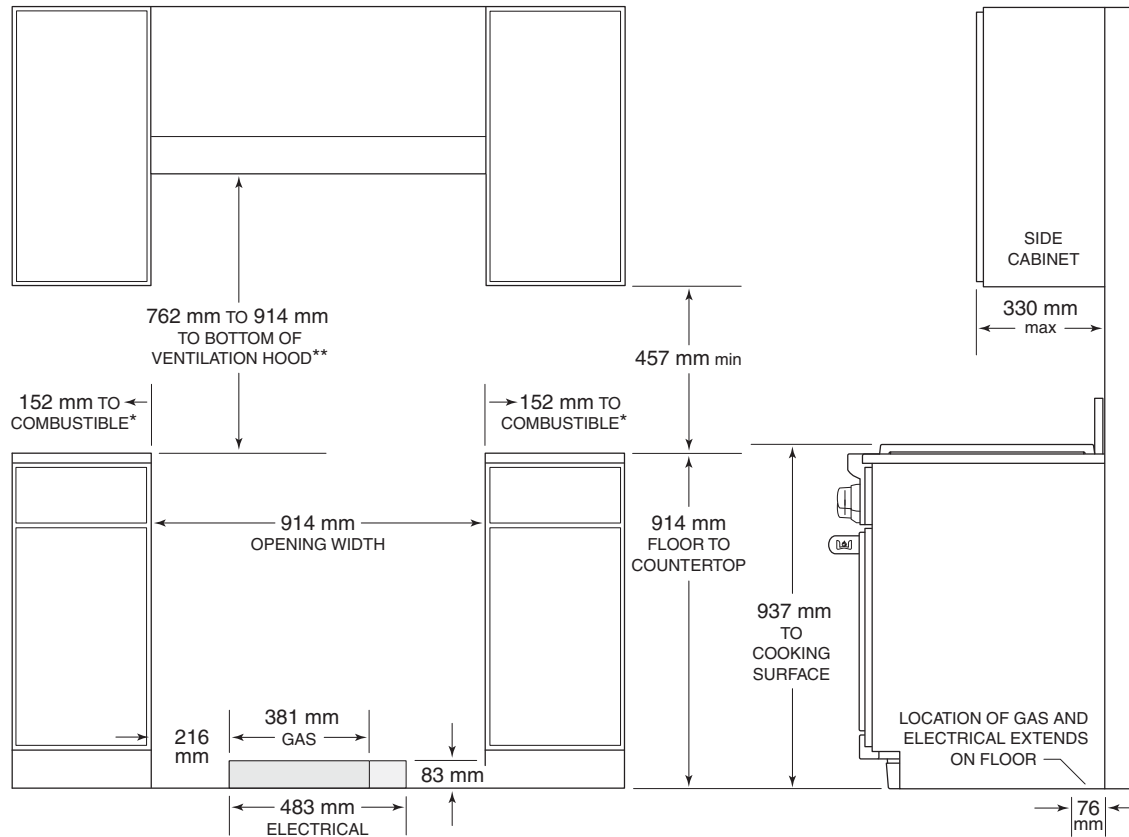

*Minimum clearance from rough opening to combustibile materials up to 457 mm above countertop.

**914 mm minimum clearance, 1118 mm for charbroiler, from countertop to combustibile materials without ventilation hood.

NOTE: For island installations, 305 mm minimum clearance from back of range to combustibile rear wall above countertop.

1219 mm Dual Fuel Range

INSTALLATION

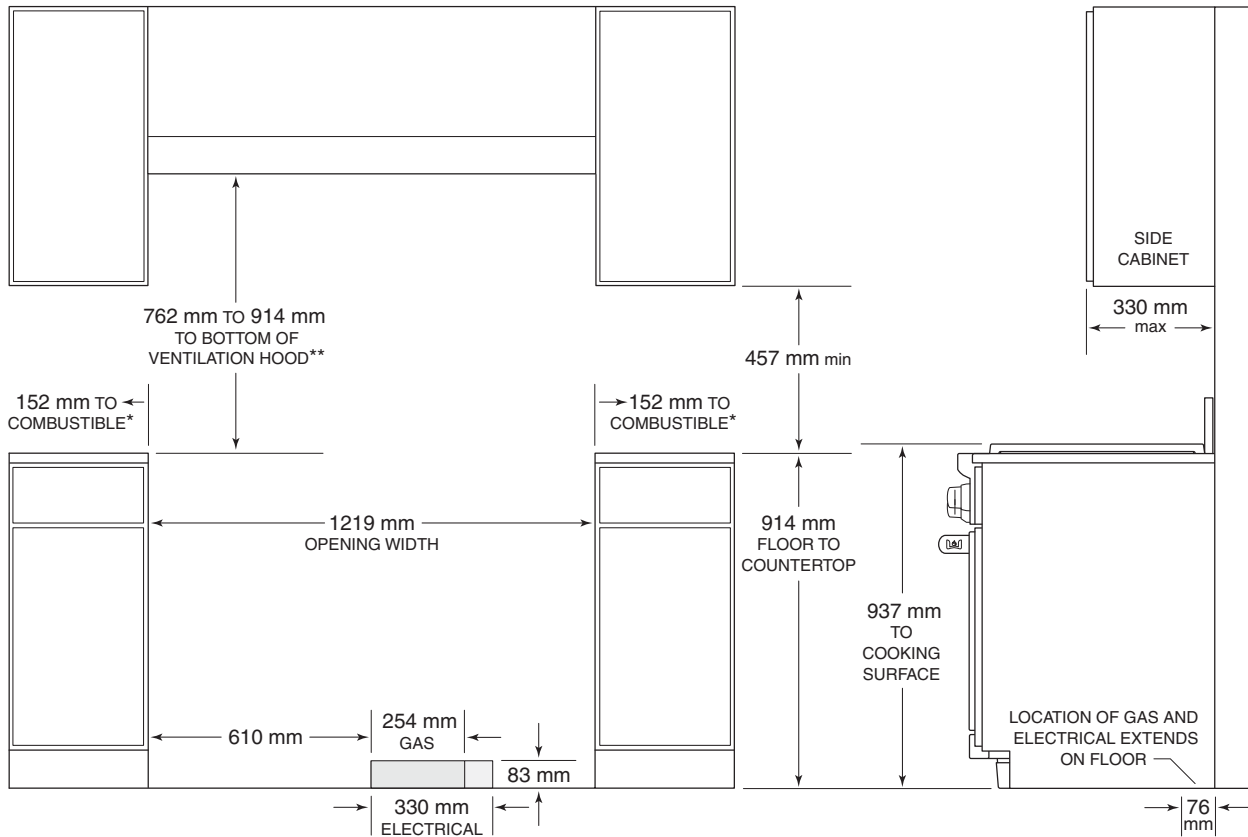

*Minimum clearance from rough opening to combustible materials up to 457 mm above countertop.

**914 mm minimum clearance, 1118 mm for charbroiler, from countertop to combustible materials without ventilation hood.

NOTE: For island installations, 305 mm minimum clearance from back of range to combustible rear wall above countertop.

1527 mm Dual Fuel Range

INSTALLATION

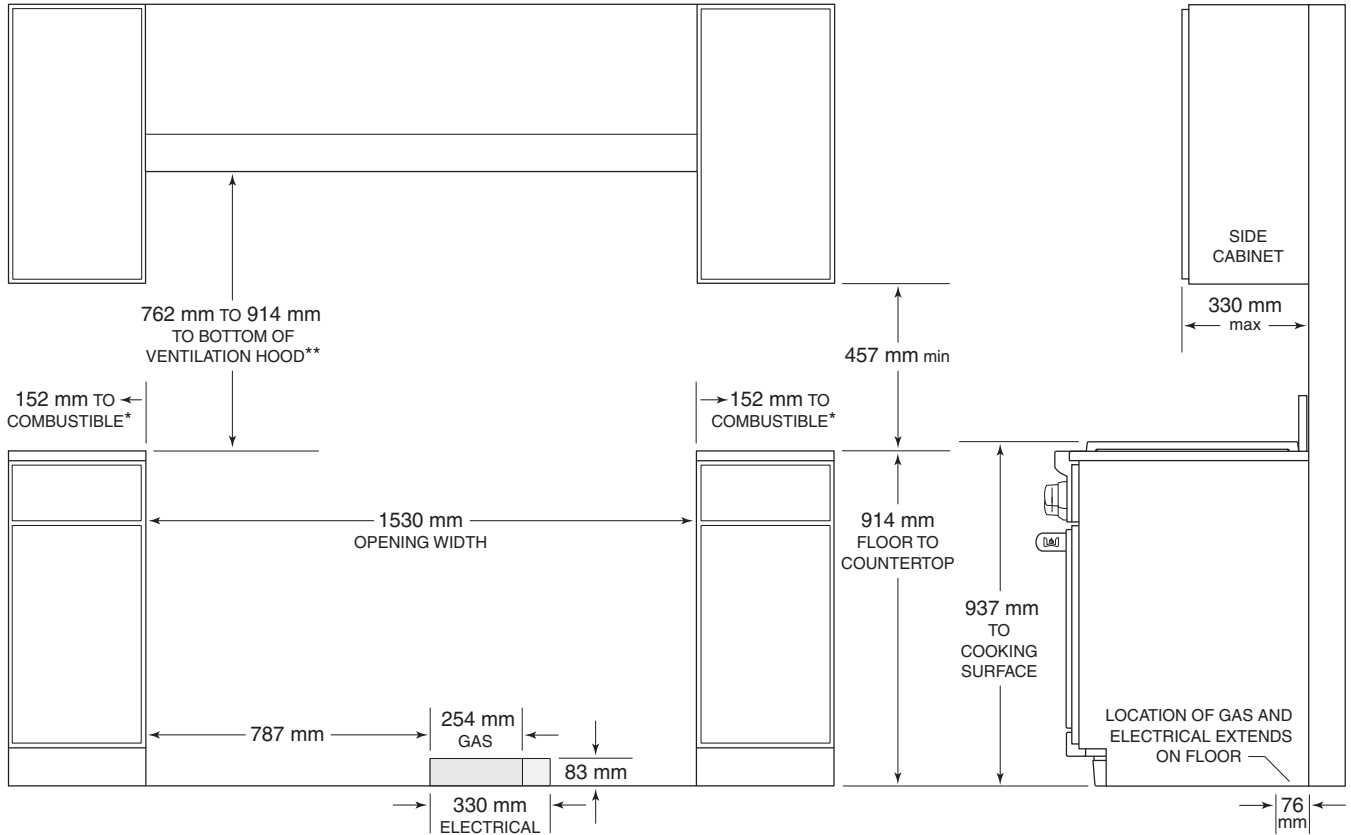

*Minimum clearance from rough opening to combustible materials up to 457 mm above countertop.

**914 mm minimum clearance, 1118 mm for charbroiler, from countertop to combustible materials without ventilation hood.

NOTE: For island installations, 305 mm minimum clearance from back of range to combustible rear wall above countertop.

Sealed Burner Rangetops. Wolf sealed burner rangetops incorporate all the gas cooking features of a Wolf dual fuel range. Customize your rangetop with your preferred combination of burners (from four to six), infrared griddle/teppan-yaki or charbroiler, or the remarkable French top. Compared with conventional electric elements, the infrared elements of the charbroiler and griddle/teppan-yaki are a revelation. They preheat almost instantly, distribute heat more evenly and deliver fast temperature recovery after food is placed on the surface. All sealed burner rangetop models have the classic stainless steel finish and can be ordered in natural or LP gas.

KEY FEATURES

- Dual-stacked, sealed burners for precise control and easy cleanup.
- Optional configurations including: infrared charbroiler, griddle/teppan-yaki and French top.
- Flame recognition and automatic reignition for safety and ease of use.
- Signature red or black control knobs with infinite control.

CONFIGURATIONS

762 mm

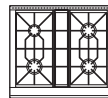

ICBSRT304

914 mm

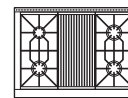

ICBSRT364C

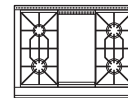

ICBSRT364G

1219 mm

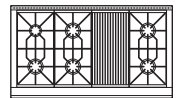

ICBSRT486C

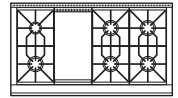

ICBSRT486G

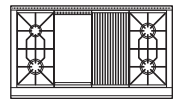

ICBSRT484CG

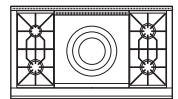

ICBSRT484F

Sealed Burner Rangetops

762 mm RANGETOP

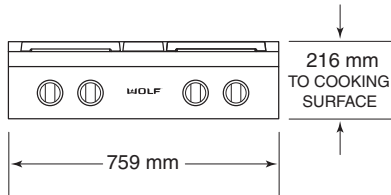

914 mm RANGETOP

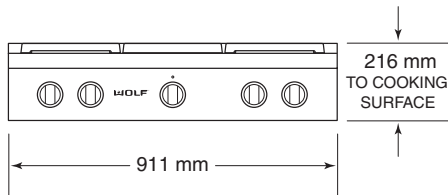

1219 mm RANGETOP

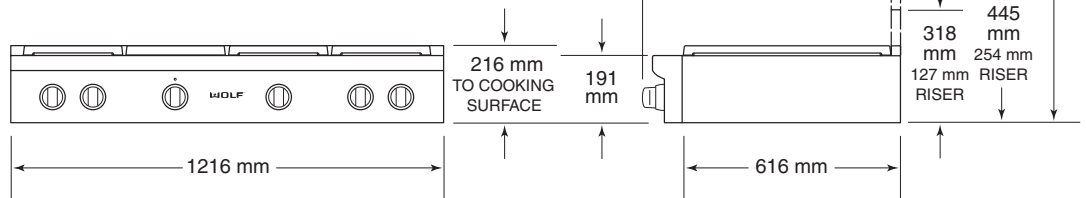

SIDE VIEW—ALL RANGETOPS

Planning Information

Available in three widths, Wolf sealed burner rangetops are designed to fit a 762 mm, 914 mm or 1219 mm opening.

The platform must be able to support 91 kg for a 762 mm rangetop, 113 kg for a 914 mm rangetop and 136 kg for a 1219 mm rangetop. The platform must include a cut-out at the right rear for gas supply and electrical connections.

IMPORTANT NOTE: When installing against a combustible surface, a minimum 254 mm riser is required for 914 mm and 1219 mm sealed burner rangetops with a charbroiler or griddle/teppan-yaki. Follow all minimum clearances to combustible surfaces shown in the installation illustrations on the following pages.

It is recommended that you use a Wolf pro ventilation hood with the sealed burner rangetop. If the rangetop is to be installed without ventilation, a 914 mm minimum clearance, 1118 mm for charbroiler, from countertop to combustible materials above the rangetop is required. Refer to page 65 for pro ventilation.

A downdraft can be used with model ICBSRT304. An accessory trim kit is necessary for this installation. Contact your Wolf dealer for details.

ELECTRICAL AND GAS REQUIREMENTS

Wolf sealed burner rangetops require a 220-240 V AC, 50/60 Hz electrical supply to operate the electronic ignition system. The 1.8 m power cord is equipped with a 3-prong, grounded plug for protection against shock hazard. Total amps for sealed burner rangetops is less than one.

A gas supply line of 19 mm rigid pipe must be provided to the rangetop. If local codes permit, a certified, .9 m long, 13 mm or 19 mm ID flexible metal appliance connector is recommended to connect the rangetop to the gas supply line.

Wolf sealed burner rangetops are designed to operate on natural gas at 20 mb pressure or LP gas at 37 mb pressure.

Burner Rating	kW	kW
SURFACE BURNERS	HIGH	SIMMER
Large	4.6	.9
(1) Small	2.8	.6
OPTIONAL FEATURES	NATURAL	LP
Infrared Charbroiler	5.8	5.3
Infrared Griddle/Teppan-Yaki	5.5	4.7
French Top	4.6	4.0

762 mm Sealed Burner Rangetop

INSTALLATION

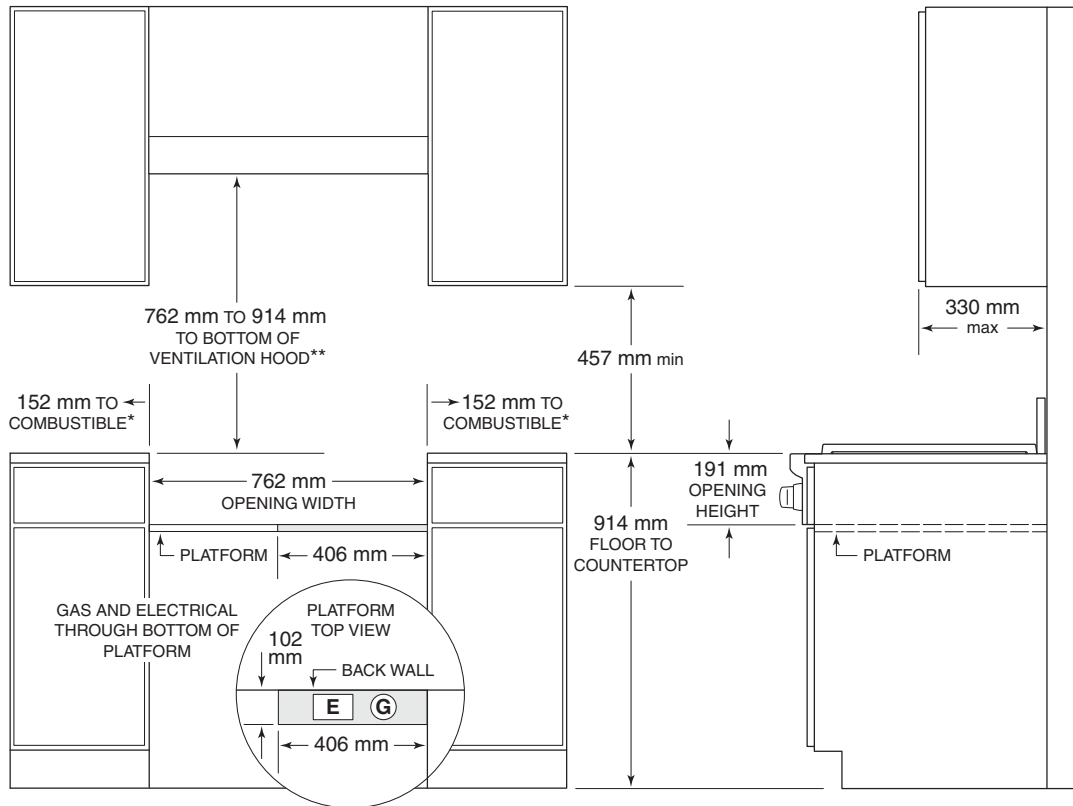

*Minimum clearance from rough opening to combustibile materials up to 457 mm above countertop.

**914 mm minimum clearance from countertop to combustibile materials without ventilation hood.

NOTE: For island installations, 305 mm minimum clearance from back of rangetop to combustibile rear wall above countertop.

914 mm Sealed Burner Rangetop

INSTALLATION

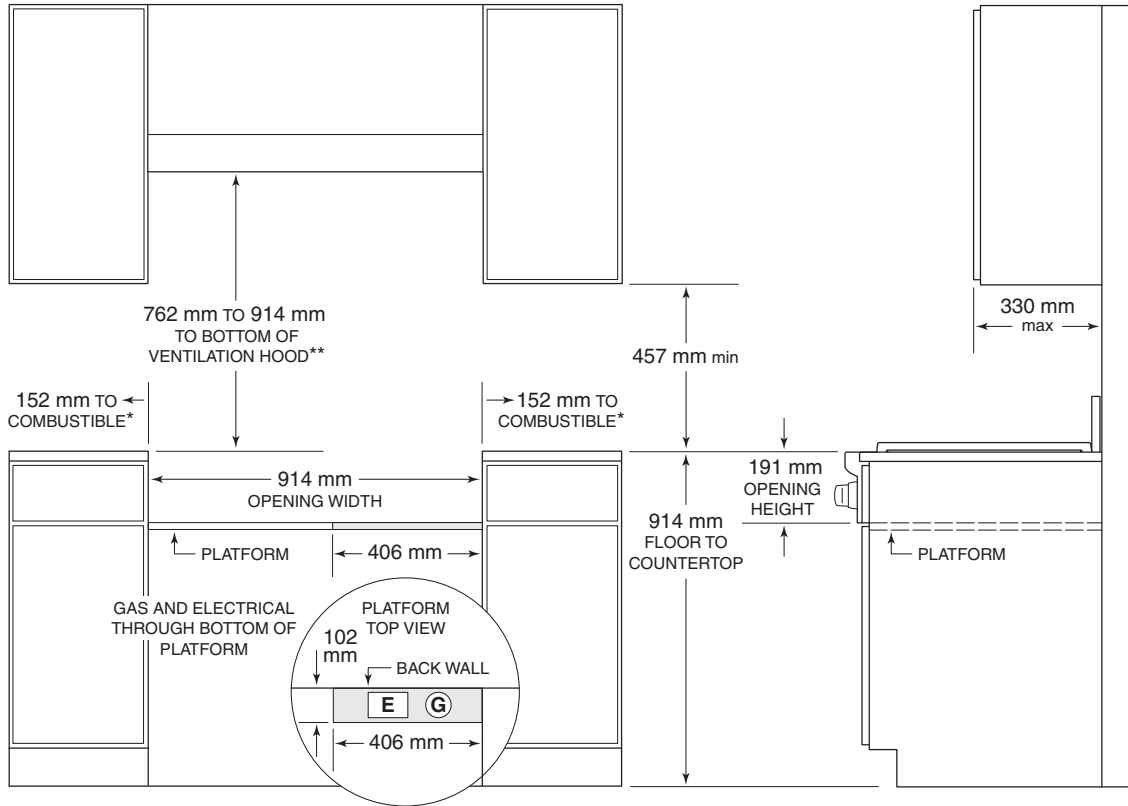

*Minimum clearance from rough opening to combustible materials up to 457 mm above countertop.

**914 mm minimum clearance, 1118 mm for charbroiler, from countertop to combustible materials without ventilation hood.

NOTE: For island installations, 305 mm minimum clearance from back of rangetop to combustible rear wall above countertop.

1219 mm Sealed Burner Rangetop

INSTALLATION

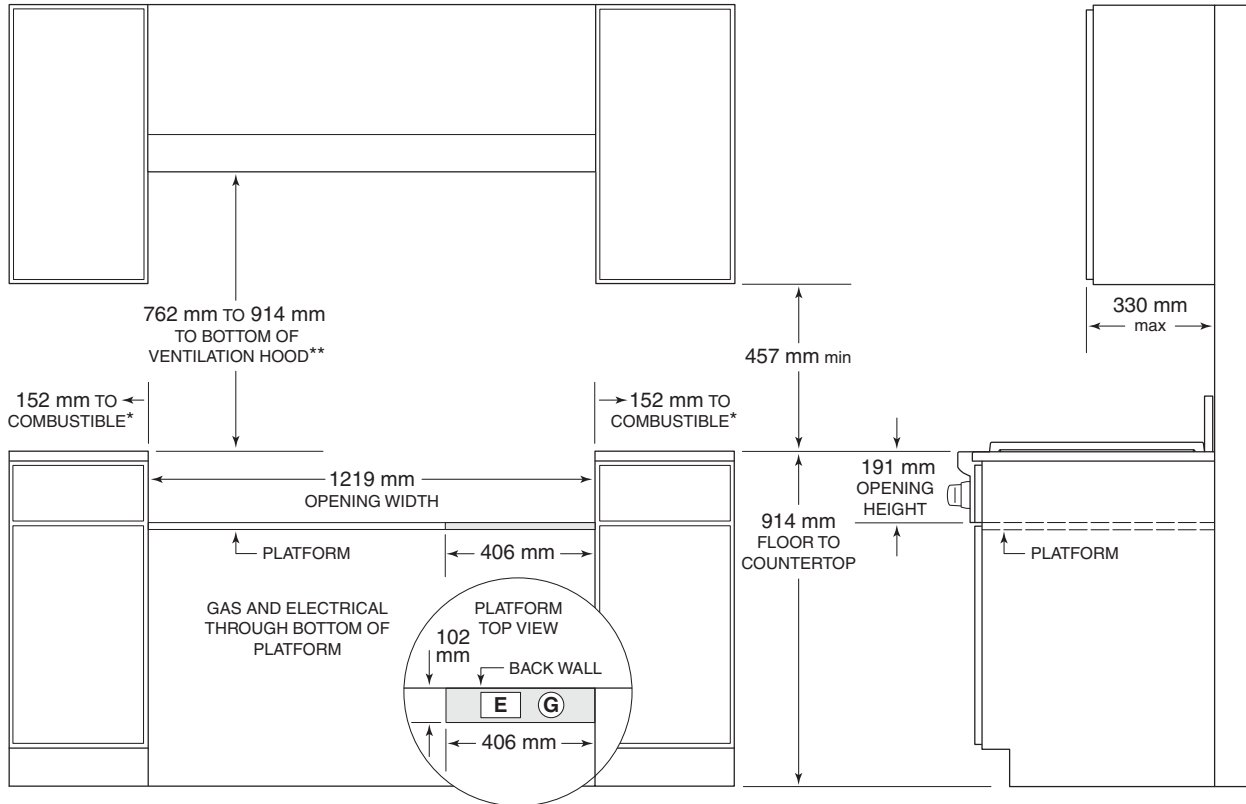

*Minimum clearance from rough opening to combustibile materials up to 457 mm above countertop.

**914 mm minimum clearance, 1118 mm for charbroiler, from countertop to combustibile materials without ventilation hood.

NOTE: For island installations, 305 mm minimum clearance from back of rangetop to combustibile rear wall above countertop.

Gas Ranges. More than seven decades in the crucible of restaurant kitchens have perfected the form, function and sheer durability of our gas ranges. These precision instruments are as noteworthy for their range of sizes and features as for their exhilarating performance. Standard features include an infrared broiler and convection baking. Dual brass burners go from extremely low flame for simmering to furnace-like 4.4 kW heat for searing. Options include infrared griddle/teppan-yaki and charbroiler. All gas ranges have the classic stainless steel finish and can be ordered in natural or LP gas.

KEY FEATURES

- Gas convection oven for even heat distribution.
- Dual brass burners delivering .3 to 4.4 kW.
- Infrared broiler with ultrafast preheating.
- Flame recognition and automatic reignition for safety and ease of use.
- Porcelain-coated, cast-iron grates for easy cleaning and durability.
- Signature red or black control knobs with infinite control.

CONFIGURATIONS

762 mm

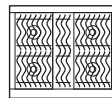

ICBR304

1219 mm

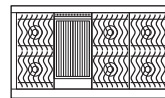

ICBR486C

1527 mm

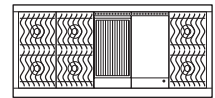

ICBR606CG

914 mm

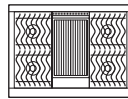

ICBR364C

ICBR486G

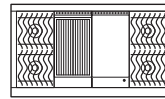

ICBR484CG

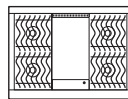

ICBR364G

Gas Ranges

762 mm RANGE

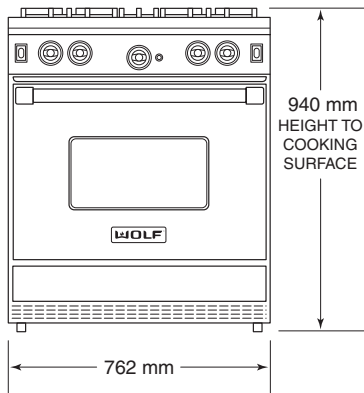

914 mm RANGE

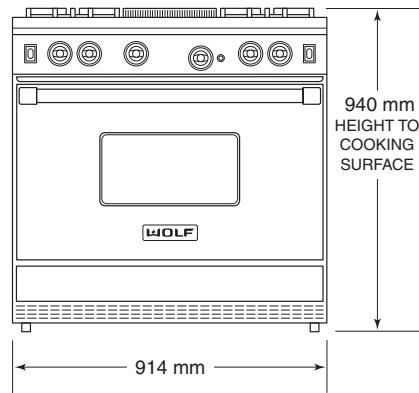

1219 mm RANGE

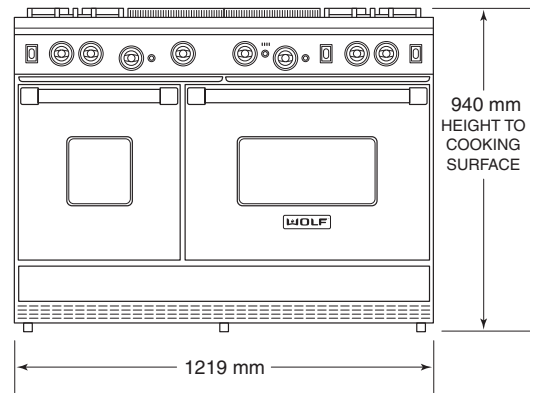

1527 mm RANGE

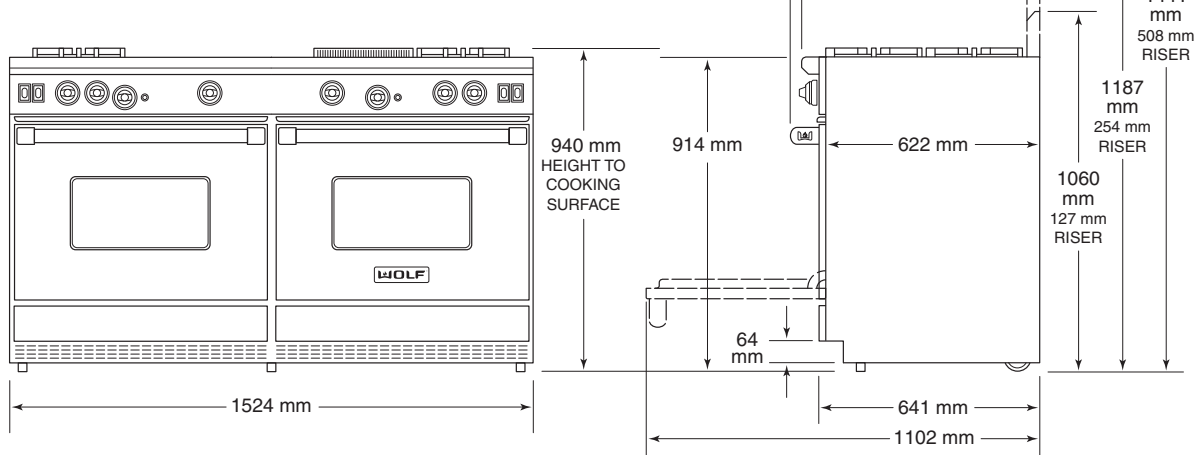

LEGS AND CASTERS ALLOW
25 mm HEIGHT ADJUSTMENT

SIDE VIEW—ALL RANGES

Planning Information

Wolf gas ranges come in 762 mm, 914 mm, 1219 mm and 1524 mm widths.

IMPORTANT NOTE: A minimum 127 mm riser is required when installing a gas range against a combustible surface. A minimum 254 mm riser is required when installing a gas range with a charbroiler or griddle/teppan-yaki against a combustible surface. Follow all minimum clearances to combustible surfaces shown in the installation illustrations on the following pages.

It is recommended that you use a Wolf pro ventilation hood with the gas range. If the range is to be installed without ventilation, a 914 mm minimum clearance, 1118 mm for charbroiler, from countertop to combustible materials above the range is required. Refer to page 65 for pro ventilation.

ELECTRICAL AND GAS REQUIREMENTS

Wolf gas ranges require a 220-240 V AC, 50/60 Hz electrical supply to operate the electronic ignition system. The 1.8 m power cord is equipped with a 3-prong, grounded plug for protection against shock hazard. Total amps for gas ranges is less than one.

A gas supply line of 19 mm rigid pipe must be provided to the range. If local codes permit, a certified, .9 m long, 13 mm or 19 mm ID flexible metal appliance connector is recommended to connect the range to the gas supply line.

Wolf gas ranges are designed with a regulator that decreases the line pressure on natural gas at 12.5 mb pressure or LP gas at 25 mb pressure. The maximum gas supply pressure to the regulator should never exceed 100 mb.

Oven Specifications			
INTERIOR CAPACITY			L
457 mm Oven			71
762 mm Oven			125
914 mm Oven			156
INTERIOR DIMENSIONS	W	H	D
457 mm Oven	343 mm	473 mm	432 mm
762 mm Oven	610 mm	473 mm	432 mm
914 mm Oven	762 mm	473 mm	432 mm

Burner Rating	kW	kW
SURFACE BURNERS	HIGH	SIMMER
4-6 Burners	4.4	.3
OPTIONAL FEATURES	NATURAL	LP
Infrared Charbroiler	4.2	4.2
Infrared Griddle/Teppan-Yaki	5.3	5.3
OVEN BURNERS		
457 mm Oven Burner	5.8	5.8
762/914 mm Oven Burner	7.8	7.8
Infrared Broiler	4.6	4.6

762 mm Gas Range

INSTALLATION

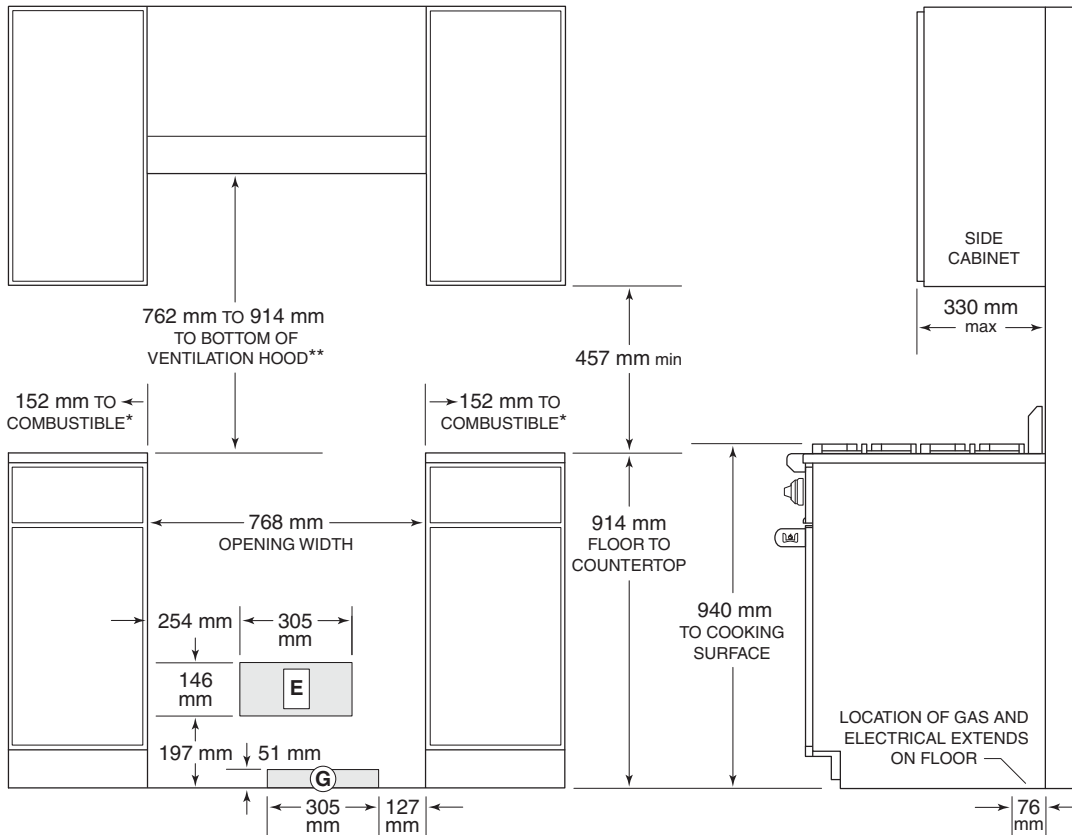

*Minimum clearance from rough opening to combustible materials up to 457 mm above countertop.

**914 mm minimum clearance from countertop to combustible materials without ventilation hood.

NOTE: For island installations, 305 mm minimum clearance from back of range to combustible rear wall above countertop.

914 mm Gas Range

INSTALLATION

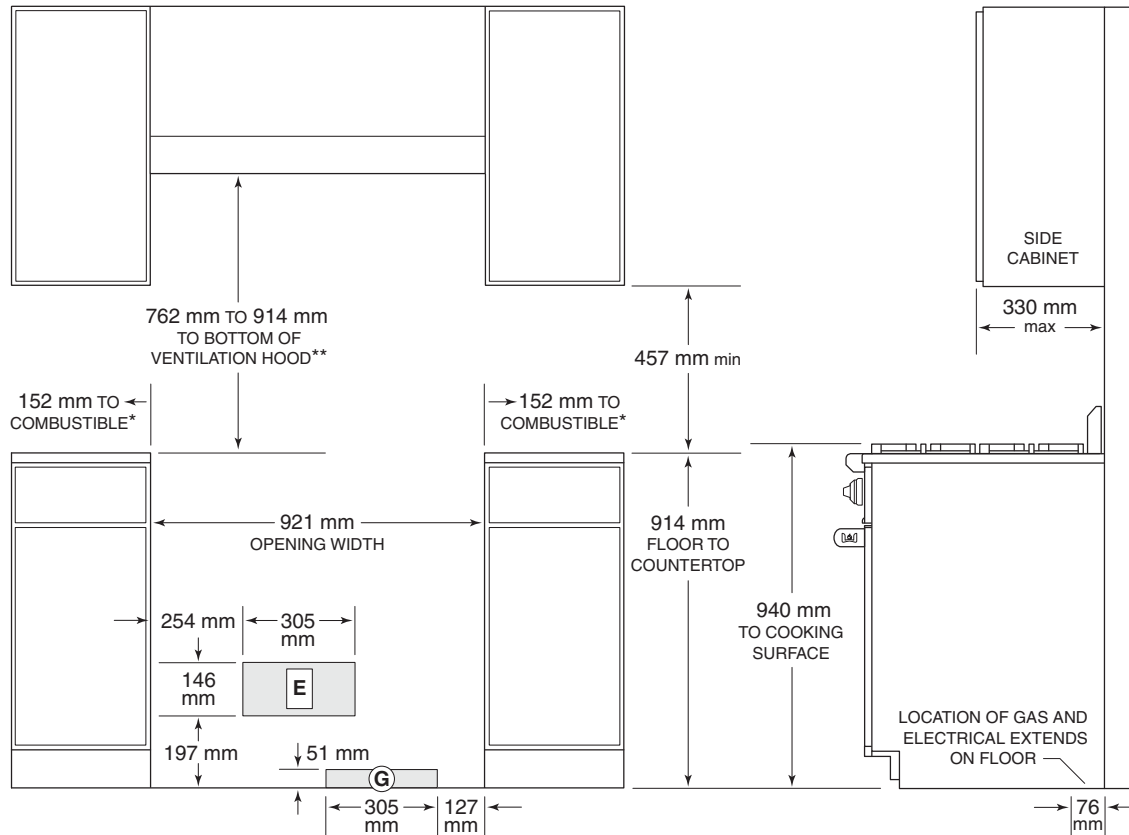

*Minimum clearance from rough opening to combustible materials up to 457 mm above countertop.

**914 mm minimum clearance, 1118 mm for charbroiler, from countertop to combustible materials without ventilation hood.

NOTE: For island installations, 305 mm minimum clearance from back of range to combustible rear wall above countertop.

1219 mm Gas Range

INSTALLATION

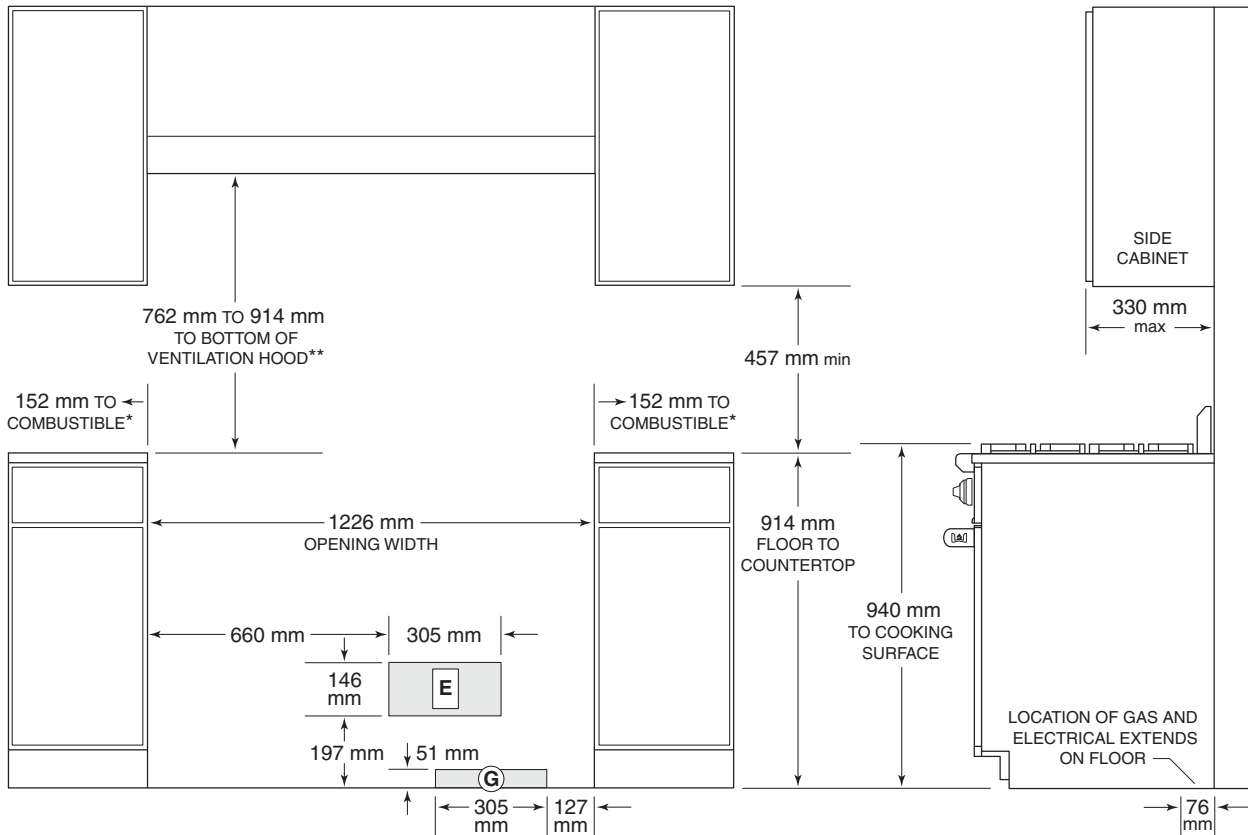

*Minimum clearance from rough opening to combustible materials up to 457 mm above countertop.

**914 mm minimum clearance, 1118 mm for charbroiler, from countertop to combustible materials without ventilation hood.

NOTE: For island installations, 305 mm minimum clearance from back of range to combustible rear wall above countertop.

1527 mm Gas Range

INSTALLATION

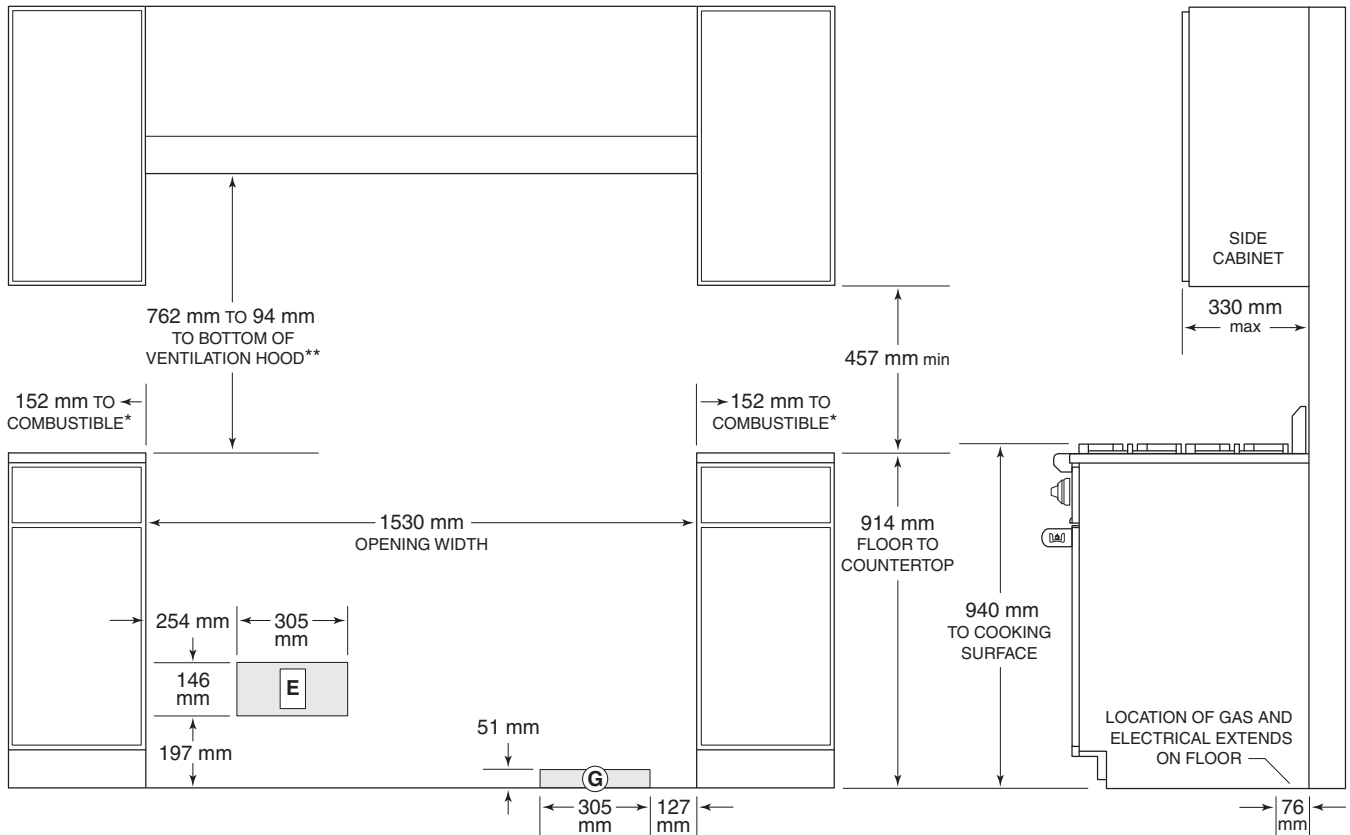

*Minimum clearance from rough opening to combustible materials up to 457 mm above countertop.

**1118 mm minimum clearance from countertop to combustible materials without ventilation hood.

NOTE: For island installations, 305 mm minimum clearance from back of range to combustible rear wall above countertop.

Low-Profile Hoods. Behind the contemporary lines of the new cooktop low-profile hoods, there's a lot of hard-nosed functional thinking. Brilliant halogen lighting illuminates your cooking surface. Powerful multi-speed blowers whisk away smoke and odors. Wall-mount and island hoods are available in the classic stainless steel finish with sleek black glass control panel.

KEY FEATURES

- Internal or remote blower options.
- Telescopic flue fits 8' to 9' ceilings.
- Models with an internal blower can be used in a non-ducted application with a recirculating filter.
- Front-mounted controls with digital indicator.
- Heat sentry to automatically turn unit on when excessive heat is sensed.
- Delay-off feature to automatically turn unit off.
- Stainless steel filter cover with dishwasher-safe aluminum mesh filter.

LOW-PROFILE HOODS



ICBCTEWH30I
762 mm WALL

ICBCTEWH36(I)
914 mm WALL

ICBCTEWH45(I)
1143 mm WALL

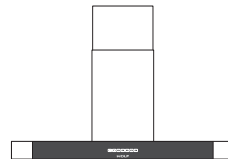

ICBCTEIH42I
1067 mm ISLAND

Low-Profile Hoods

WALL HOODS

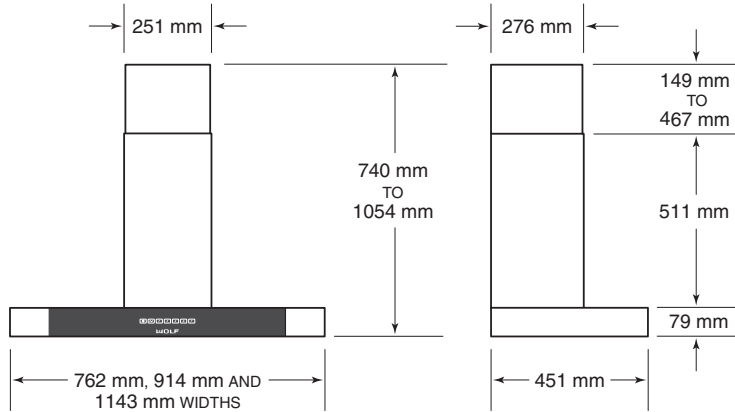

ISLAND HOOD

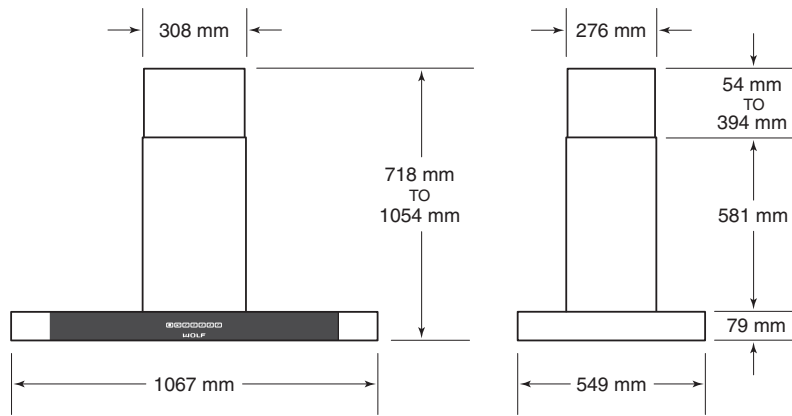

Planning Information

Wolf cooktop low-profile hoods are recommended for use with Wolf electric and gas cooktops and integrated modules. These hoods have a telescopic flue that allows you to reach a ceiling height of 2.4 m to 2.7 m with a finished look.

Low-profile wall and island hoods are available with an internal blower. Wall hood models ICBCTEWH36 and ICBCTEWH45 will require a remote blower assembly, available through your Wolf dealer. For local distributor information, visit the international section of our website, wolfappliance.com.

The blower will vary in size and is dictated by the cooking unit, the volume of air that needs to be moved and the length of the duct run. Refer to ventilation recommendations on pages 71–72. These hoods have an 203 mm round duct with vertical discharge.

Cooktop low-profile hoods with an internal blower can be used in a non-ducted application with a recirculating filter. In this installation, kitchen air is purified through filters and returned as clean air into the room. A recirculation kit available through your Wolf dealer is required.

Consult a qualified HVAC professional for specific installation and ducting applications.

ELECTRICAL REQUIREMENTS

Wolf low-profile wall and island hoods require a separate, grounded 220-240 V AC, 50/60 Hz power supply. Total amps for cooktop hoods is less than one.

Low-Profile Wall Hood

INSTALLATION

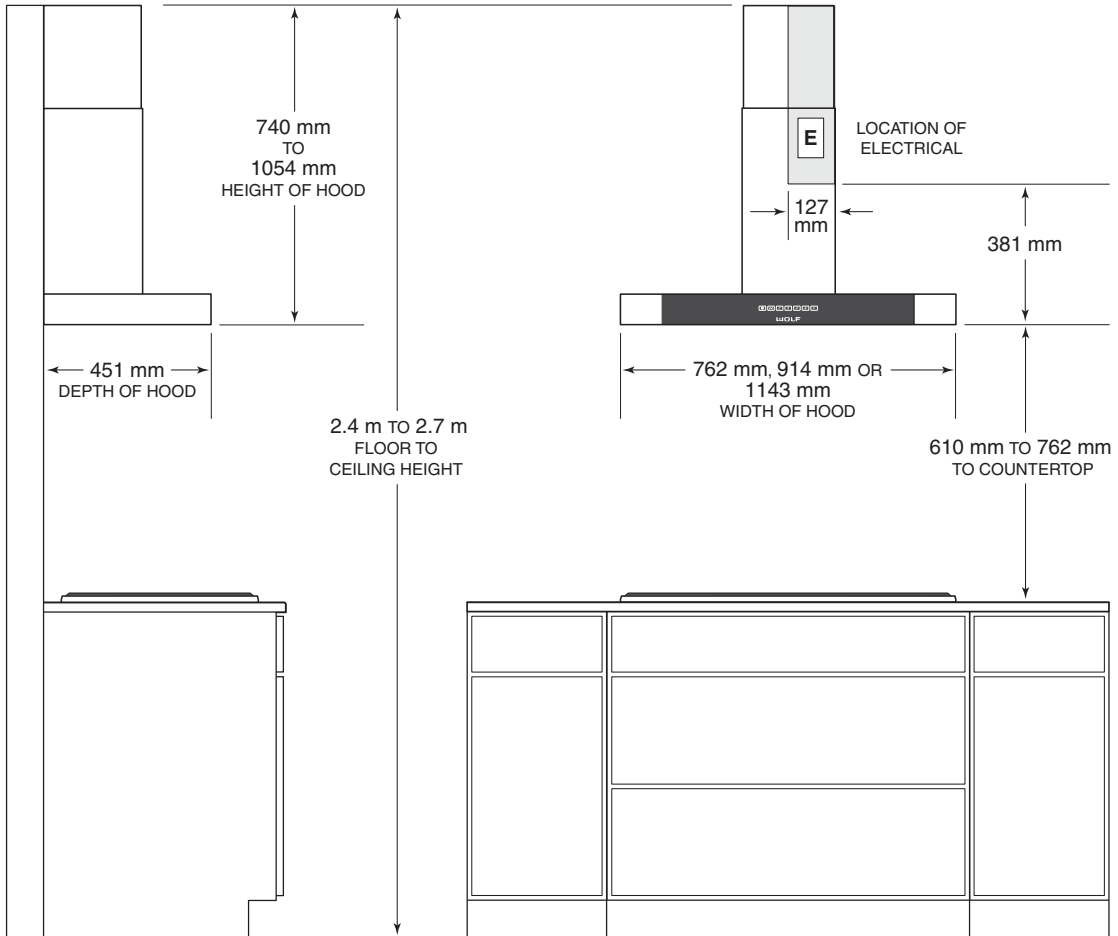

Low-Profile Island Hood

INSTALLATION

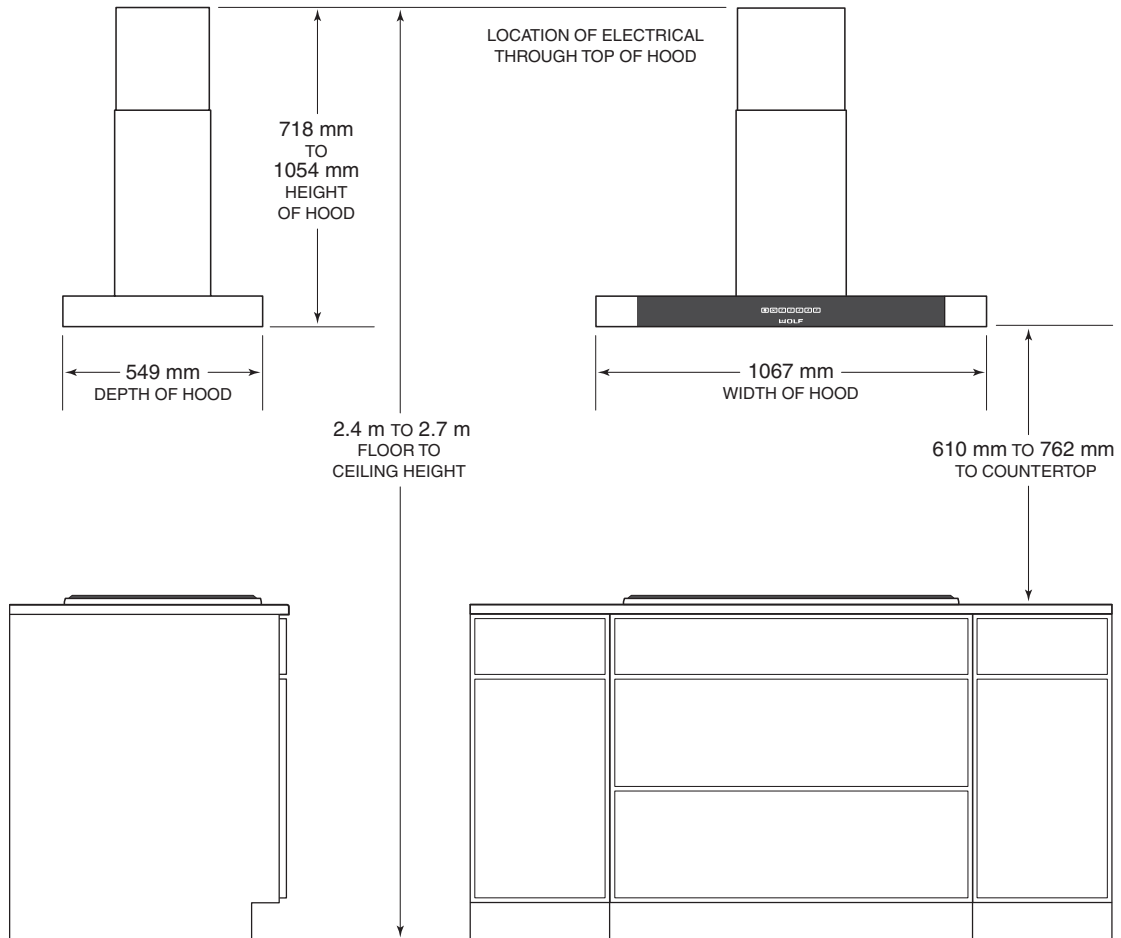

Downdraft Ventilation. The cooktop downdraft unit rises from the countertop to whisk away odors and smoke into the easy-to-clean, five-layer mesh filter and can be lowered beneath the countertop when not in use. The control module and top cover are available in classic stainless steel for ease in matching your cooktop.

KEY FEATURES

- Internal or remote blower options.
- Top cover and controls available in classic stainless steel.
- Remote-mounted controls with LED indicators.
- Delay-off feature to automatically turn unit off.
- Stainless steel filter cover with dishwasher-safe aluminum mesh filter.

DOWNDRAFTS

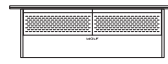

ICBDD30I / ICBDD30R
762 mm

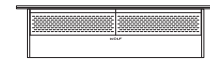

ICBDD36I / ICBDD36R
914 mm

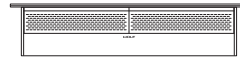

ICBDD45I / ICBDD45R
1143 mm

Downdrafts

762 mm DOWNDRAFT

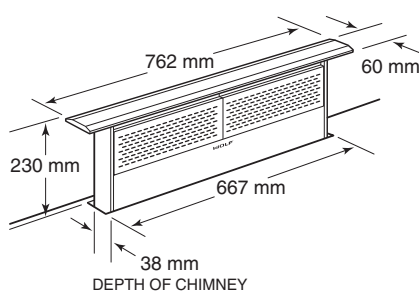

914 mm DOWNDRAFT

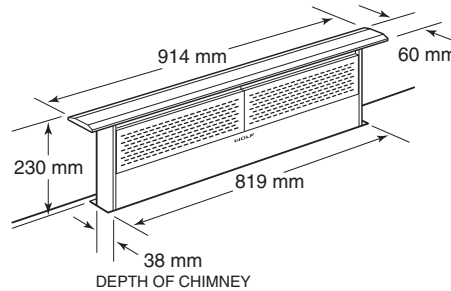

1143 mm DOWNDRAFT

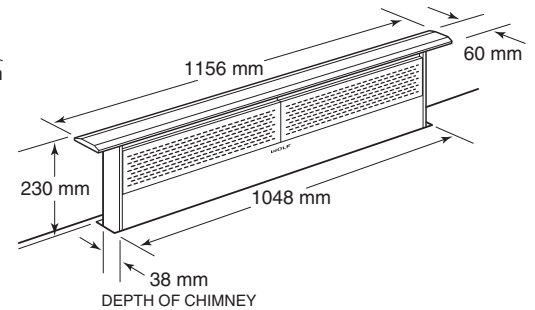

Planning Information

Wolf downdraft systems can be used with Wolf electric and gas cooktops, except unframed models. They can also be used with some integrated modules but are not recommended for use with the electric grill, steamer and fryer modules. A downdraft can also be used with sealed burner rangetop model ICBSRT304. An accessory trim kit is necessary for this installation. Contact your Wolf dealer for details.

IMPORTANT NOTE: To install a downdraft with a Wolf cooktop, you must allow for a minimum 638 mm flat counter space from front to back. A countertop with a raised lip or backsplash may not allow enough space for proper installation.

Installation of the remote-mounted control module must be within 3 m of the downdraft assembly and a minimum of 102 mm from the outer edge of cooktop element or burner.

Downdraft models ICBDD30I, ICBDD36I and ICBDD45I include an 845 m³/hr internal blower. Remote blower assemblies are available for models ICBDD30R, ICBDD36R and ICBDD45R through your Wolf dealer. For local distributor information, visit the international section of our website, wolfappliance.com.

The blower will vary in size and is dictated by the cooking unit, the volume of air that needs to be moved and the length of the duct run. Refer to ventilation recommendations on pages 71–72.

Downdrafts with an internal blower have a 83 mm x 254 mm duct and for remote blower models, a 83 mm x 356 mm duct. All downdrafts have an adjustable discharge.

Consult a qualified HVAC professional for specific installation and ducting applications.

ELECTRICAL REQUIREMENTS

Wolf downdraft ventilation systems require a separate, grounded 220-240 V AC, 50/60 Hz power supply. A grounded 3-prong receptacle should be located within reach of the .8 m power cord. Certain installations may require that the electrical supply be placed in an adjacent cabinet. Maximum total amps for downdraft systems is 3 amps.

Downdrafts

INSTALLATION WITH COOKTOP

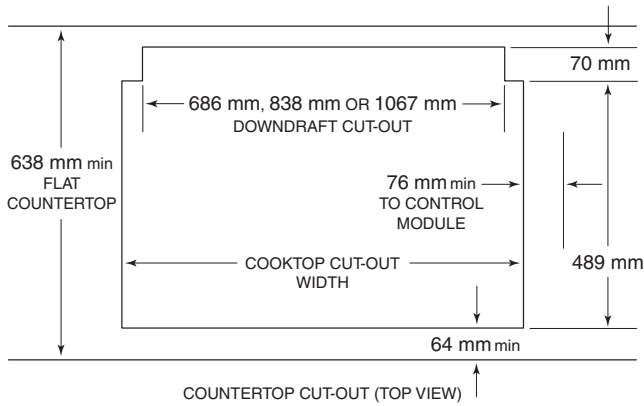

INSTALLATION WITH SEALED BURNER RANGETOP

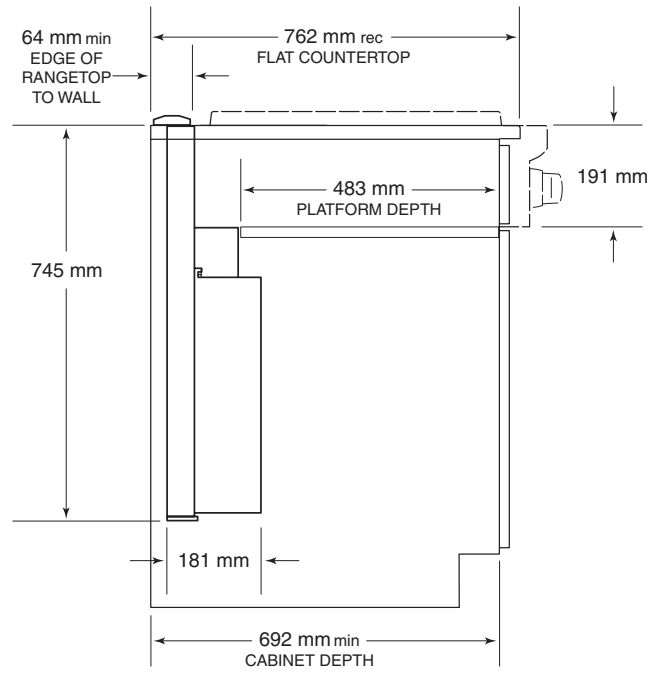
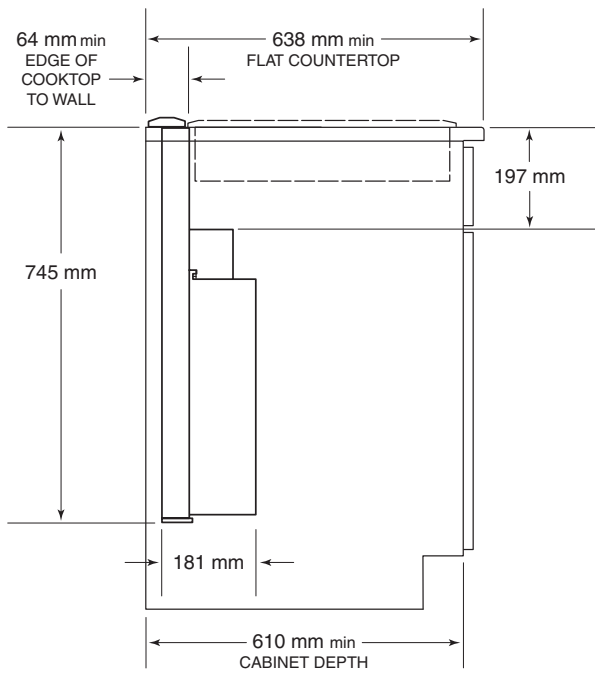
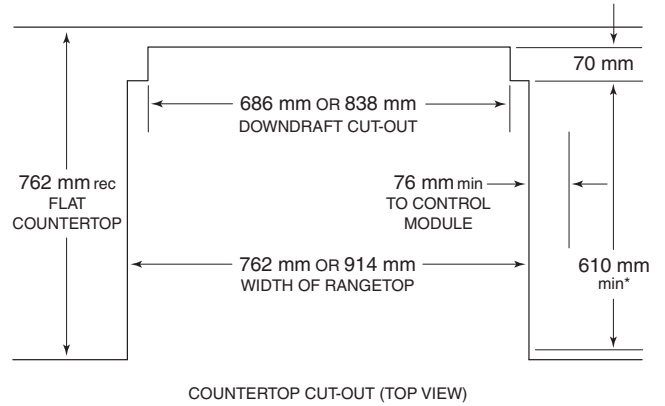

*Additional depth may be required if rangetop is to be installed flush with cabinet face.

Pro Ventilation Hoods. Professional heritage shines through in Wolf professional-style ventilation. Exteriors are heavy-duty, welded stainless steel, so finely hand-finished that they appear seamless. Pro hoods are available in a variety of widths. Stainless steel baffle filters and halogen lighting extend the professional look and back it up with pro-level performance.

KEY FEATURES

- Internal or remote blower options.
- Recessed easy-access controls.
- Infinite-speed ventilator control.
- Heat sentry to automatically turn unit on when excessive heat is sensed.
- Easy-to-clean stainless steel baffle filters.
- Heat lamp receptacles on 686 mm deep models (bulbs not included).

PRO HOODS



610 mm Deep
WALL HOOD



686 mm Deep
WALL HOOD

Pro Hoods

610 mm DEEP WALL HOODS

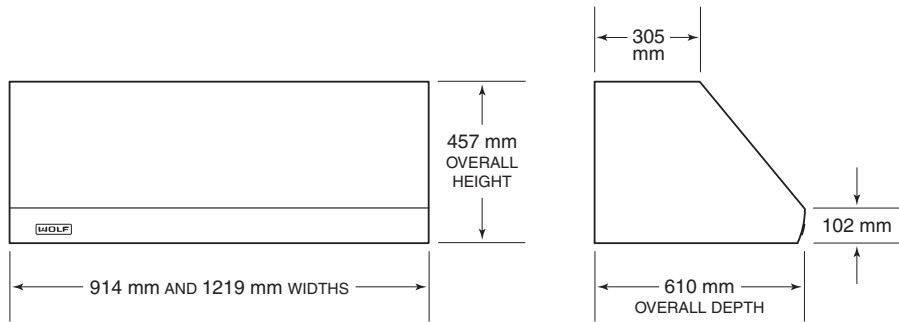

686 mm DEEP WALL HOODS

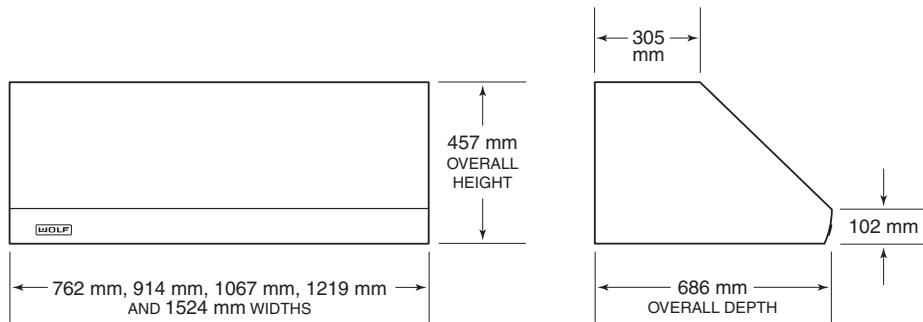

Planning Information

Pro ventilation hoods are recommended for use with all Wolf cooking appliances. Wall hoods should be at least as wide as the cooking surface.

IMPORTANT NOTE: For optimal performance in wall hood applications, a pro 686 mm deep wall hood is recommended for use with ranges and rangetops that contain a charbroiler or griddle/teppan-yaki.

All pro ventilation hoods are shipped without the blower assembly. Internal and remote blowers are available through your Wolf dealer. The blower will vary in size and is dictated by the cooking unit, the volume of air that needs to be moved and the length of the duct run. Refer to ventilation recommendations on pages 71–72.

Pro hoods have a 254 mm round duct and vertical discharge. A horizontal discharge kit is available through your Wolf dealer.

Consult a qualified HVAC professional for specific installation and ducting applications.

Optional classic stainless steel duct covers in a variety of heights are available for all pro wall hoods through your Wolf dealer. For local distributor information, visit the international section of our website, wolfappliance.com.

ELECTRICAL REQUIREMENTS

Wolf pro ventilation hoods require a separate, grounded 220-240 V AC, 50/60 Hz power supply. Maximum amps for pro ventilation hoods is 4.8 amps.

RECIRCULATING INSTALLATION

610 mm and 686 mm deep wall hoods with an internal blower (1014 m³/hr or less), 762 mm and 914 mm widths only, can be used in a non-ducted application with a recirculating filter. In this installation, kitchen air is purified through filters and returned as clean air into the room. A recirculation kit available through your Wolf dealer is required.

610 mm Deep Wall Hood

INSTALLATION

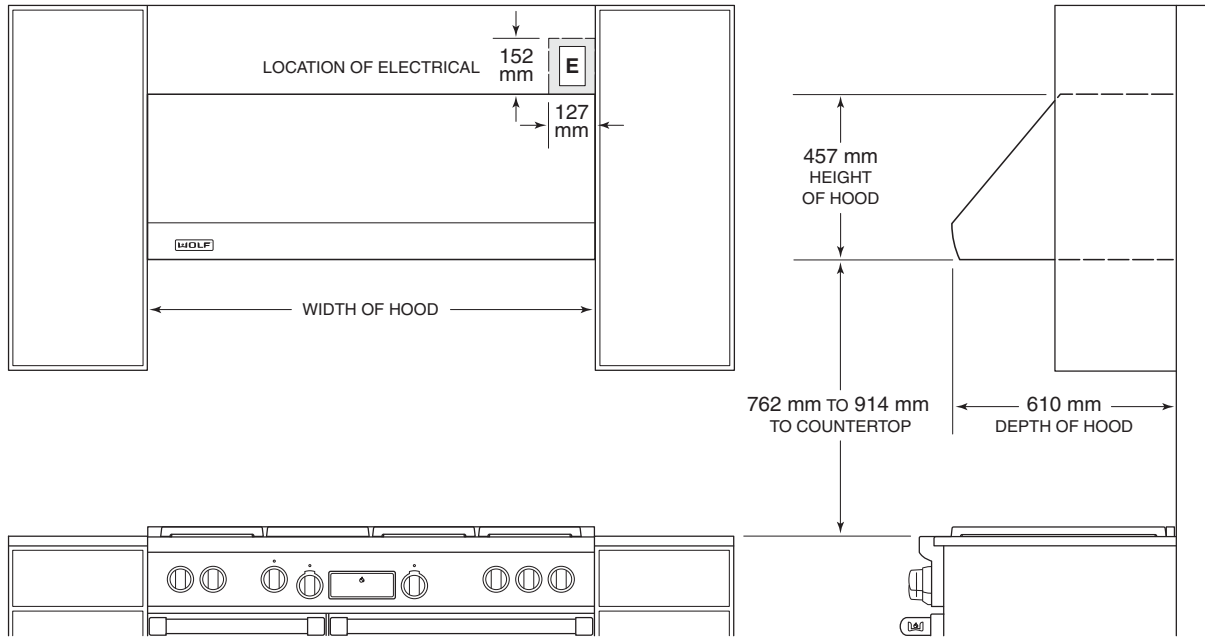

686 mm Deep Wall Hood

INSTALLATION

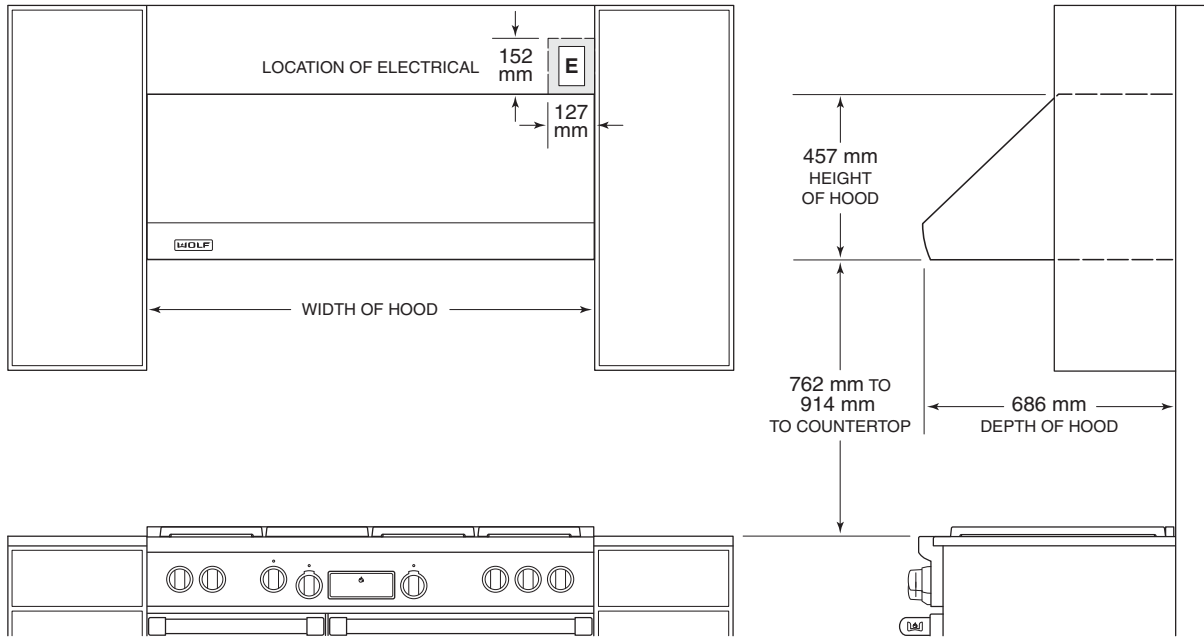

Blower Assemblies

For Wolf ventilation hoods and downdrafts that do not include a blower assembly, an internal or remote blower assembly must be selected to accommodate the cooking appliance, m³/hr requirements and homeowner preferences. Internal and remote blowers are available through your Wolf dealer. For local distributor information, visit the international section of our website, wolfappliance.com.

Ventilation recommendations on the following pages provide m³/hr recommendations and blower options for each ventilation hood and downdraft.

Refer to the illustrations below for dimensions of Wolf remote blowers. Installation instructions shipped with each Wolf ventilation product provide detailed specifications. These instructions can also be found on our website, wolfappliance.com/specs.

Remote Blowers

1014 m³/hr and 1521 m³/hr

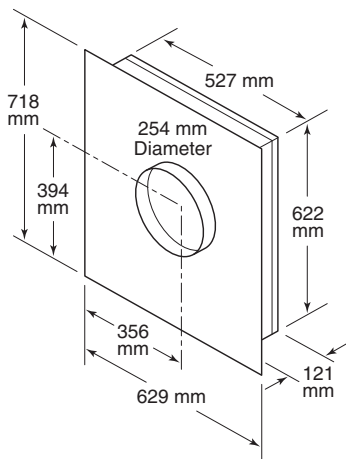

2028 m³/hr

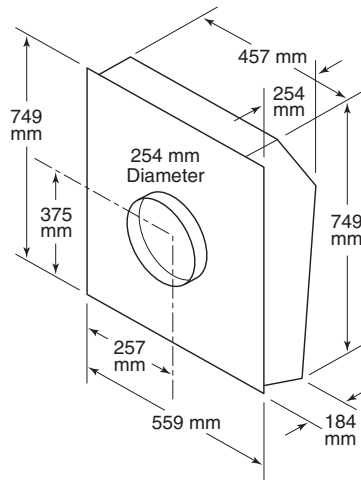

2535 m³/hr

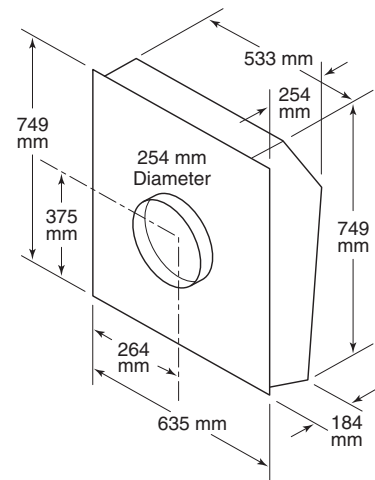

Wolf Product m³/hr Recommendations

	COOKTOP HOODS	DOWNDRAFTS	PRO HOODS
MODEL	MINIMUM m ³ /hr	MINIMUM m ³ /hr	MINIMUM m ³ /hr
COOKTOPS			
ICBCT15E ICBCT15G	363	254	363
ICBCT30E ICBCT30EU ICBCT30G	761	592	845
ICBCT36E ICBCT36EU ICBCT36G	1014	845	845
INTEGRATED MODULES			
ICBIG15 ICBIS15 ICBIF15	363	Not Recommended	363
ICBIM15	363	254	363
DUAL FUEL RANGES			
ICBDF366 ICBDF364C ICBDF364G			1521
ICBDF486C ICBDF486G ICBDF484CG ICBDF484F			1859
ICBDF606CG ICBDF604CF			2535
SEALED BURNER RANGETOPS			
ICBSRT304		845	845
ICBSRT364C ICBRT364G			1521
ICBSRT486C ICBRT486G ICBRT484CG ICBRT484F			1521
GAS RANGES			
ICBR304			845
ICBR364C ICBRT364G			1521
ICBR486C ICBRT486G ICBRT484CG			1859
ICBR606CG			2535

m³/hr recommendations are based on total kW output. Wolf recommends 1.69 m³/hr per .03 kW. Additional m³/hr may be required for long duct runs or ranges and rangetops with a charbroiler or griddle/teppan-yaki.

Wolf Ventilation Blower Options

	INTERNAL			REMOTE			
m ³ /hr	1014	1521	1859	946	1521	2028	2535
BLOWER	813160	813161	813162	CE 900 TI	812307	812308	812309
COOKTOP LOW-PROFILE HOODS							
ICBCTEWH36				•	•		
DOWNDRAFTS							
ICBDD30R					•	•	•
ICBDD36R					•	•	•
ICBDD45R					•	•	•
PRO 610 mm WALL HOODS							
ICBPW362418	•	•			•	•	•
ICBPW482418	•	•			•	•	•
PRO 686 mm WALL HOODS							
ICBPW302718	•	•			•	•	•
ICBPW362718	•	•			•	•	•
ICBPW422718	•	•			•	•	•
ICBPW482718			•		•	•	•
ICBPW602718			•			•	•

Wolf Product Shipping Weights

Shipping Weights	kg
E SERIES OVENS	
762 mm Single Oven	124
762 mm Double Oven	211
MICROWAVE OVEN	
Convection Microwave with Grill	34
WARMING DRAWER	
762 mm Warming Drawer	45
ELECTRIC COOKTOPS	
381 mm Cooktop	14
762 mm Framed / Unframed	20
914 mm Framed / Unframed	27
GAS COOKTOPS	
381 mm Cooktop	14
762 mm Cooktop	23
914 mm Cooktop	30
INTEGRATED MODULES	
Electric Grill	23
Electric Steamer	18
Electric Fryer	14
Multi-Function Cooktop	14

Shipping Weights	kg
DUAL FUEL RANGES	
914 mm Range	202–213
1219 mm Range	302–340
1524 mm Range	397–431
SEALED BURNER RANGETOPS	
762 mm Rangetop	73
914 mm Rangetop	86–100
1219 mm Rangetop	109–127
GAS RANGES	
762 mm Range	147
914 mm Range	202–213
1219 mm Range	295–340
1524 mm Range	397–431
COOKTOP VENTILATION HOODS	
762 mm Low-Profile Wall Hood	24
914 mm Low-Profile Wall Hood	23–26
1143 mm Low-Profile Wall Hood	25–28
1067 mm Low-Profile Island Hood	42
DOWNDRAFT VENTILATION	
762 mm Downdraft	34
914 mm Downdraft	36
1143 mm Downdraft	39
PRO VENTILATION HOODS	
610 mm Deep Wall Hoods	38–67
686 mm Deep Wall Hoods	42–74

WOLF APPLIANCE, INC.
PO BOX 44848
MADISON, WI 53744 USA
WOLFAPPLIANCE.COM