



Design Guide

ICB REVISED 1/2024



Contents

3	M Series Ovens
16	E Series Ovens
24	Convection Steam Ovens
31	Speed Ovens
36	Warming Drawers
41	Induction Cooktops
46	Gas Cooktops
50	Module Cooktops
58	Coffee Systems
63	Vacuum Seal Drawer
67	Dual Fuel Ranges
72	Induction Ranges
76	Sealed Burner Rangetops
80	Outdoor Grills Modules Accessories
91	Cooktop Ventilation
98	Downdraft Ventilation
102	Pro Ventilation
106	Ventilation Suggestions
110	Wolf Warranties



Features and specifications are subject to change at any time without notice.

Throughout this guide, dimensions may vary by ± 3 mm.

M Series Built-In Ovens

Four striking looks are just the beginning. Superior performance features include our dual convection fan system, touch-screen controls, convenient preset cooking programs, and improved interior lighting. There is more usable space inside for deliciousness on a grand scale. M Series Ovens can be installed in a standard or flush inset application.

M SERIES OVENS

TRANSITIONAL

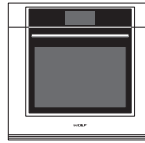

ICBSO3050TM/S/TH

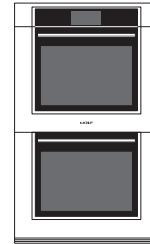

ICBDO3050TM/S/TH

PROFESSIONAL

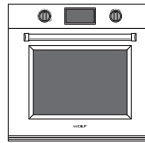

ICBSO3050PM/S/PH

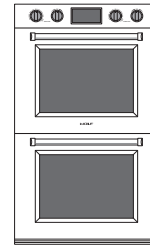

ICBDO3050PM/S/PH

CONTEMPORARY



ICBSO3050CM/S



ICBSO3050CM/B



ICBDO3050CM/S



ICBDO3050CM/B

M Series Built-In Ovens

TRANSITIONAL SINGLE OVEN

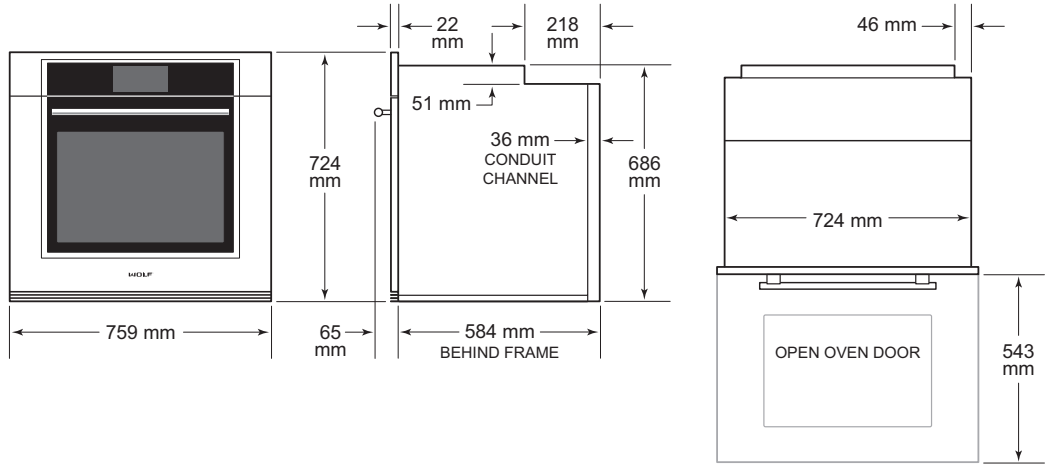

TRANSITIONAL DOUBLE OVEN

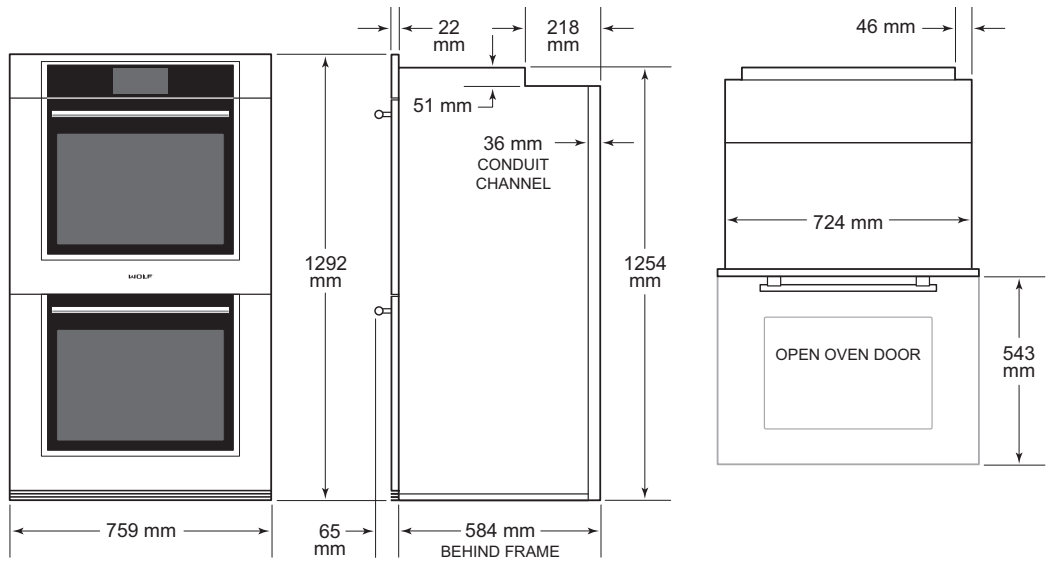

M Series Ovens

M Series Built-In Ovens

PROFESSIONAL SINGLE OVEN

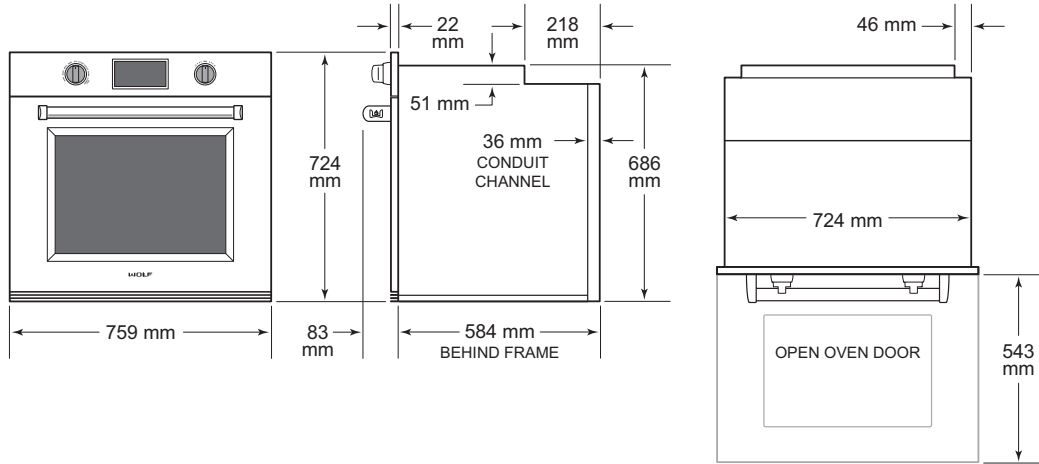

PROFESSIONAL DOUBLE OVEN

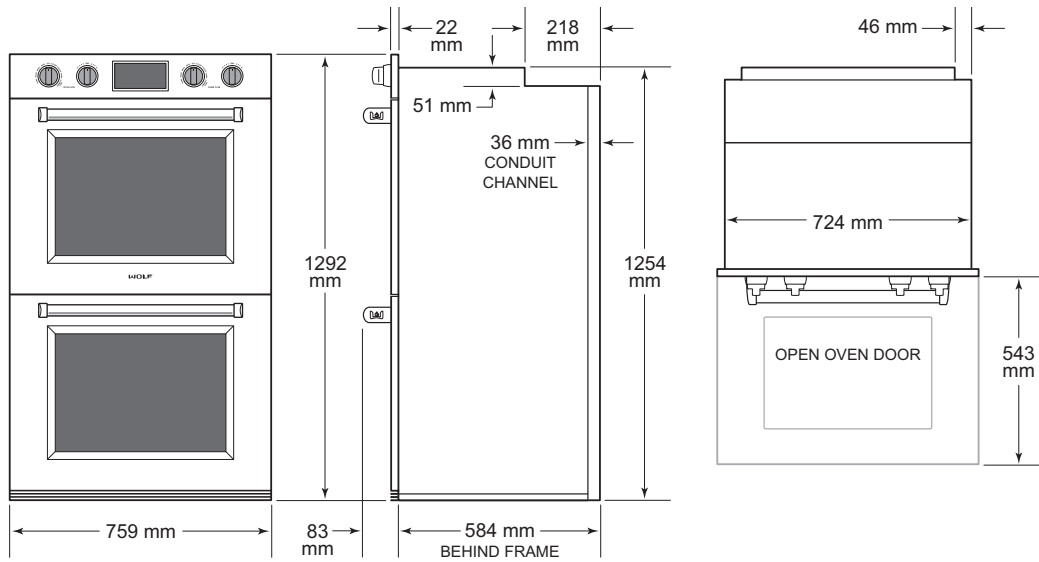

M Series Built-In Ovens

CONTEMPORARY STAINLESS STEEL SINGLE OVEN

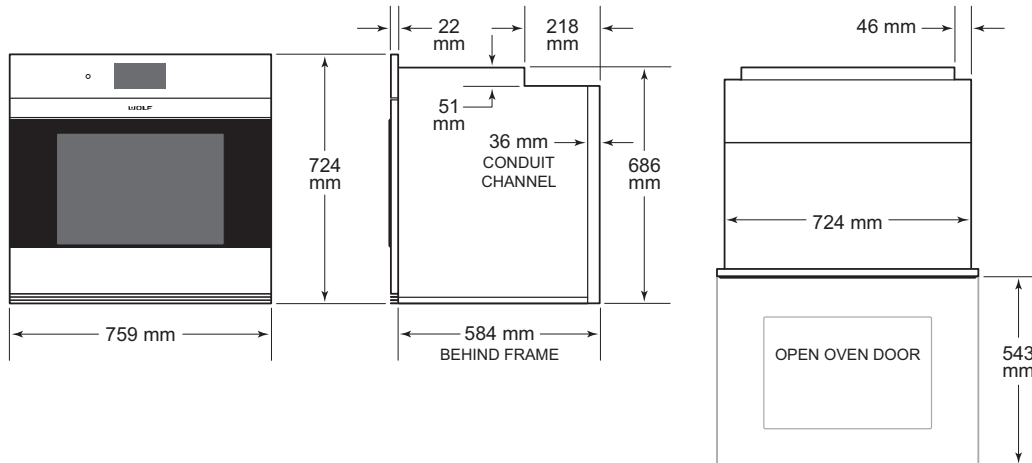

CONTEMPORARY STAINLESS STEEL DOUBLE OVEN

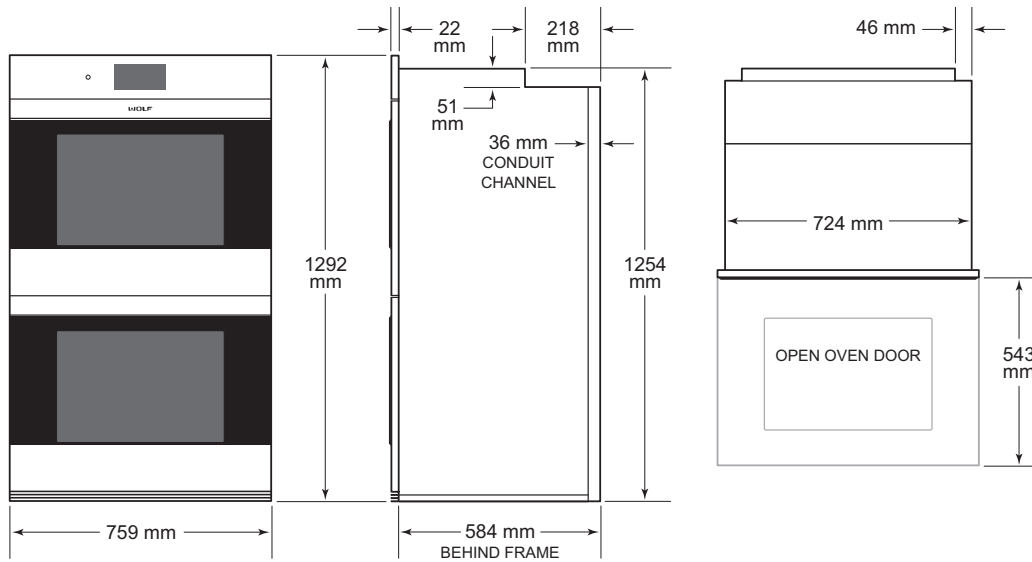

M Series Built-In Ovens

CONTEMPORARY BLACK GLASS SINGLE OVEN

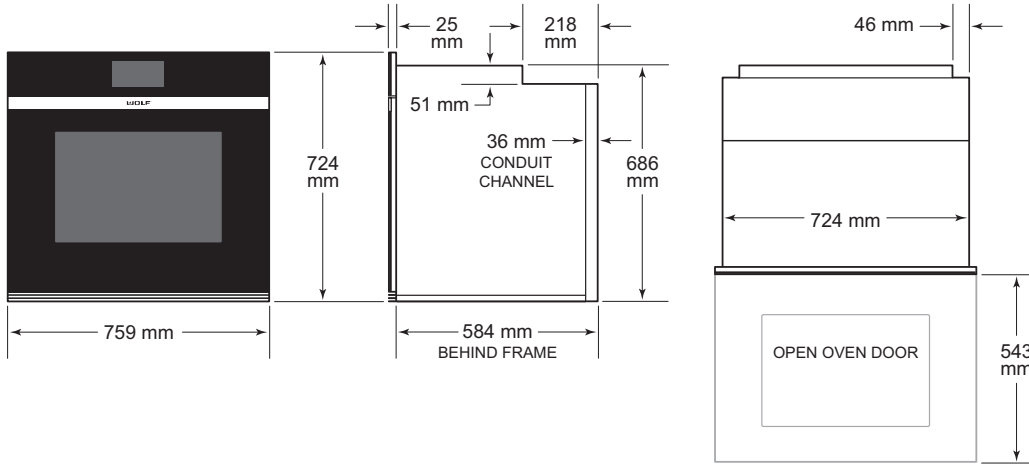

CONTEMPORARY BLACK GLASS DOUBLE OVEN

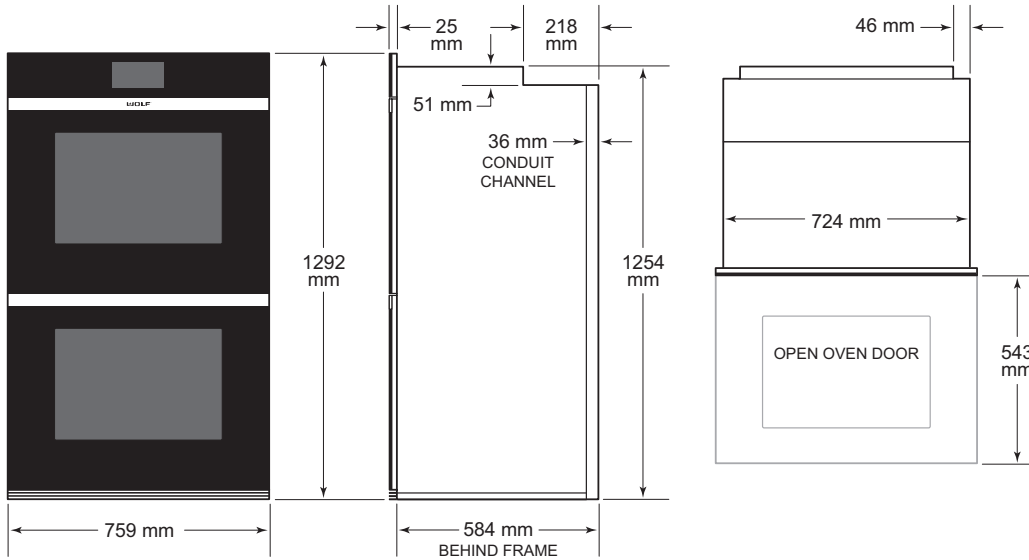

Planning Information

The M Series Oven can be installed in a standard or flush inset application. If a cooktop is installed above an oven, a minimum of 6 mm is required between the units. Location of the electrical supply within the oven opening may require additional cabinet depth.

Finish the edges of the opening. They may be visible when the door is open.

For standard installations, the face trim will overlap stiles and rails. Refer to the chart below.

For flush inset installations, a minimum 3 mm reveal is required on all sides. To ensure consistent reveals, each corner of the opening must be exactly 90°.

INSTALLATION REQUIREMENTS

BASE SUPPORT	MIN
Single Oven	115 kg
Double Oven	181 kg

TRIM OVERLAP	
Top	25 mm
Bottom	0 mm
Sides	18 mm

DUAL INSTALLATION

Two 76 cm single M Series Ovens can be installed side by side in a standard or flush inset application. A dual installation kit is required. To maintain appropriate airflow, the ovens must be installed into one opening. Any cosmetic or structural material placed between the ovens will impede airflow and is not recommended. Refer to the illustrations on the following pages.

The dual installation kit is available through an authorized Wolf dealer.

Planning Information

ELECTRICAL REQUIREMENTS

Installation must comply with all applicable electrical codes and be properly grounded (earthed).

Locate the electrical supply flush with the back wall and within the shaded area shown in the illustration for your specific installation on the following pages. For ease of installation, the electrical supply for the oven can be placed in an adjacent cabinet within reach of the conduit.

Performance may be compromised if the electrical supply is less than 220 volts.

The oven is supplied with a single phase and 3-phase convertible power inlet box. The wiring diagram covering the control circuit is provided with the oven.

ELECTRICAL REQUIREMENTS—SINGLE OVEN

ELECTRICAL SUPPLY

Single Phase	220–240 V AC, 50/60 Hz
3-Phase	380–415 V AC, 50 Hz

MAX CONNECTED LOAD

Single Phase	4.2–4.8 kW
3-Phase	3.0–3.6 kW

ELECTRICAL REQUIREMENTS—DOUBLE OVEN

ELECTRICAL SUPPLY

Single Phase	220–240 V AC, 50/60 Hz
3-Phase	380–415 V AC, 50 Hz

MAX CONNECTED LOAD

Single Phase	8.4–9.6 kW
3-Phase	4.2–4.8 kW

M Series Single Oven

STANDARD INSTALLATION

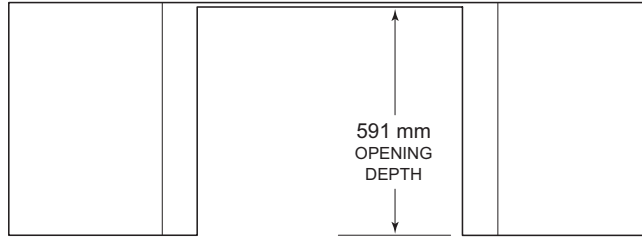

TOP VIEW

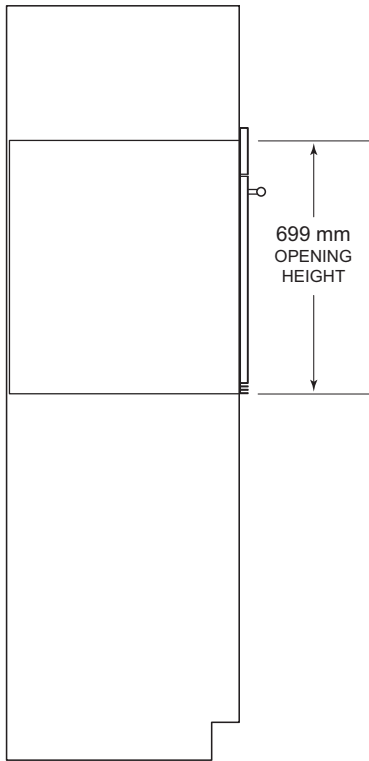

SIDE VIEW

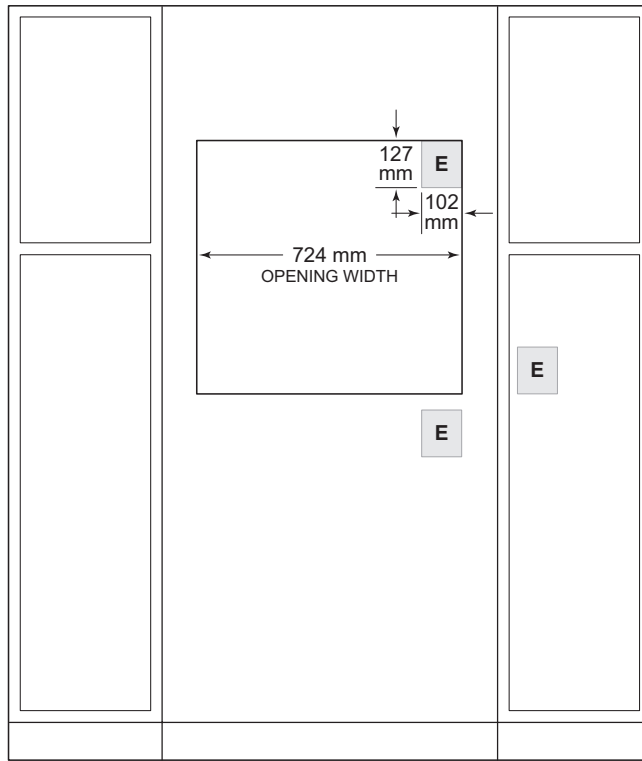

FRONT VIEW

NOTE: Location of electrical supply within opening may require additional cabinet depth.

M Series Single Oven

FLUSH INSET INSTALLATION

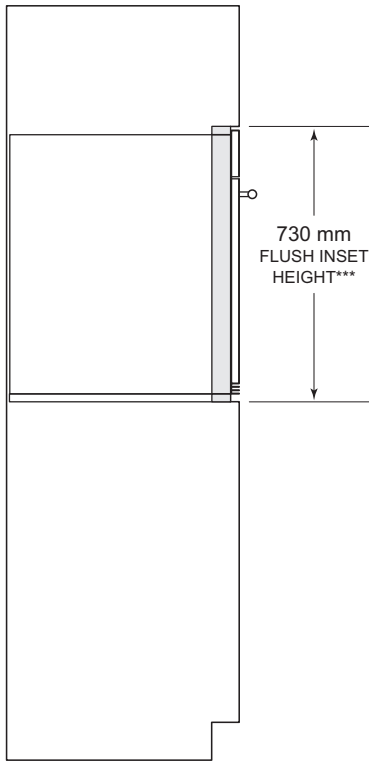
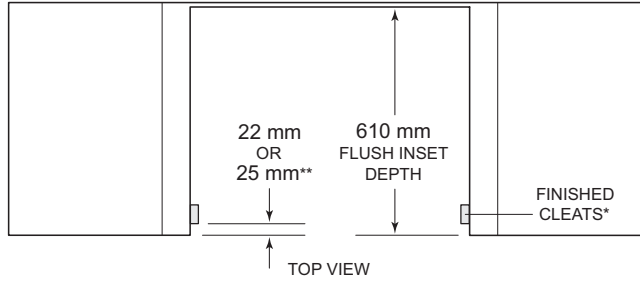

SIDE VIEW

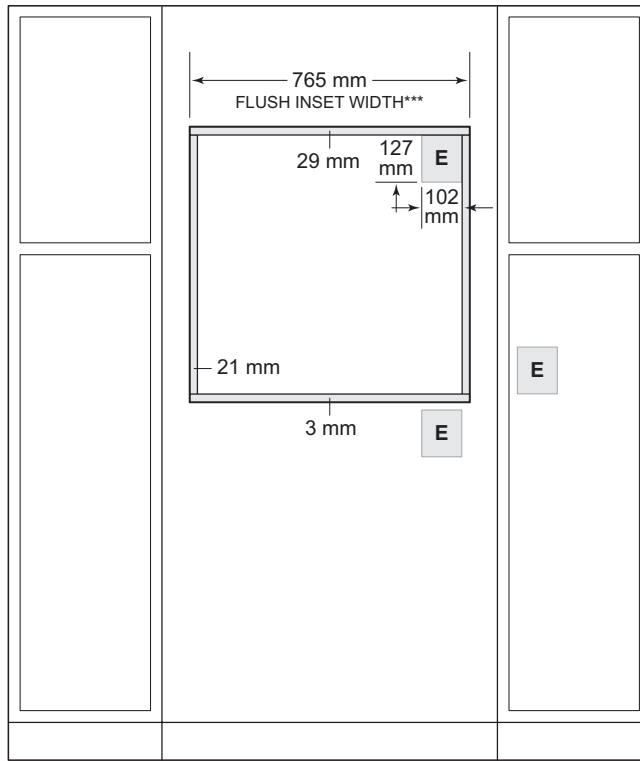

FRONT VIEW

*25 mm minimum depth. Shaded areas will be visible and should be finished to match cabinetry.

**22 mm for transitional, professional and contemporary stainless steel models and 25 mm for contemporary black glass model.

***Dimension provides minimum reveals.

NOTE: Location of electrical supply within opening may require additional cabinet depth.

M Series Double Oven

STANDARD INSTALLATION

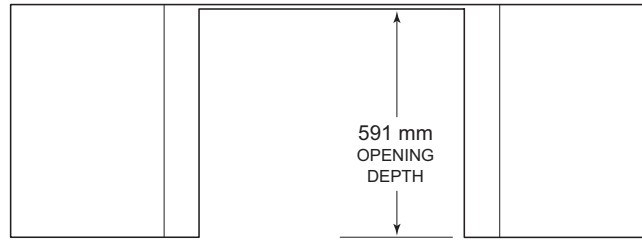

TOP VIEW

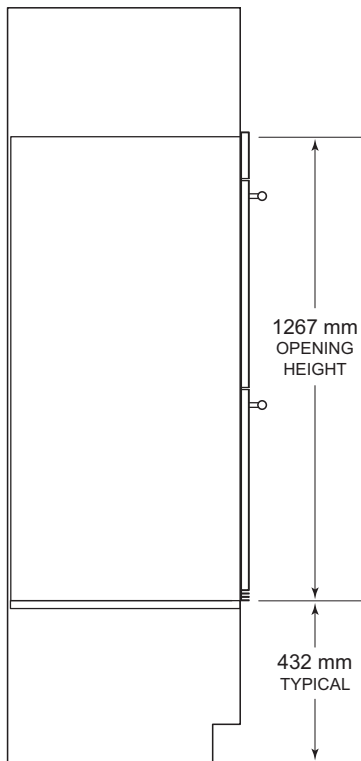

SIDE VIEW

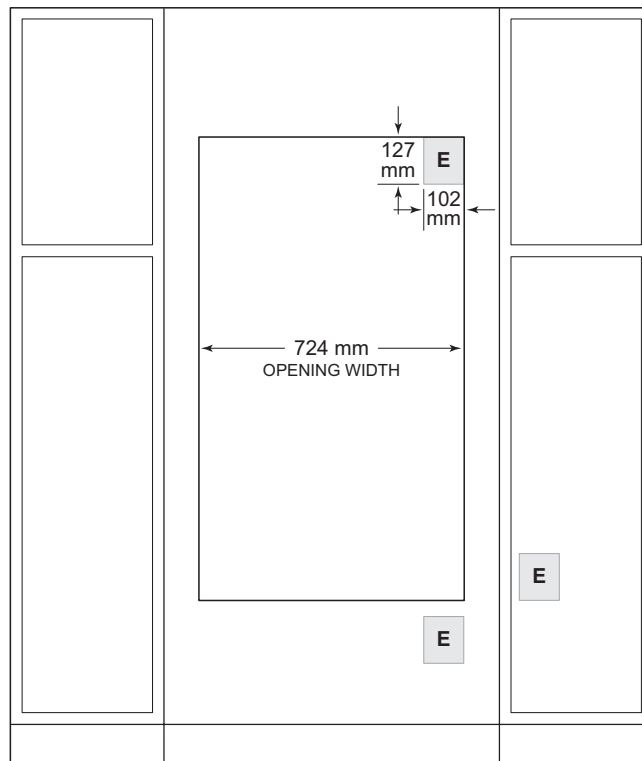

FRONT VIEW

NOTE: Location of electrical supply within opening may require additional cabinet depth.

M Series Double Oven

FLUSH INSET INSTALLATION

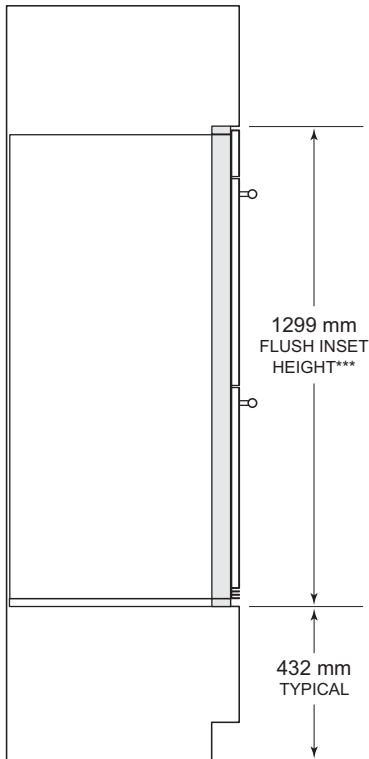
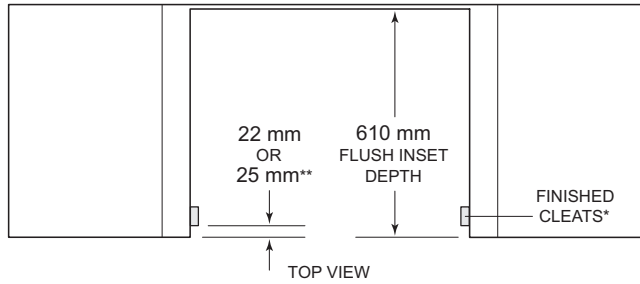

SIDE VIEW

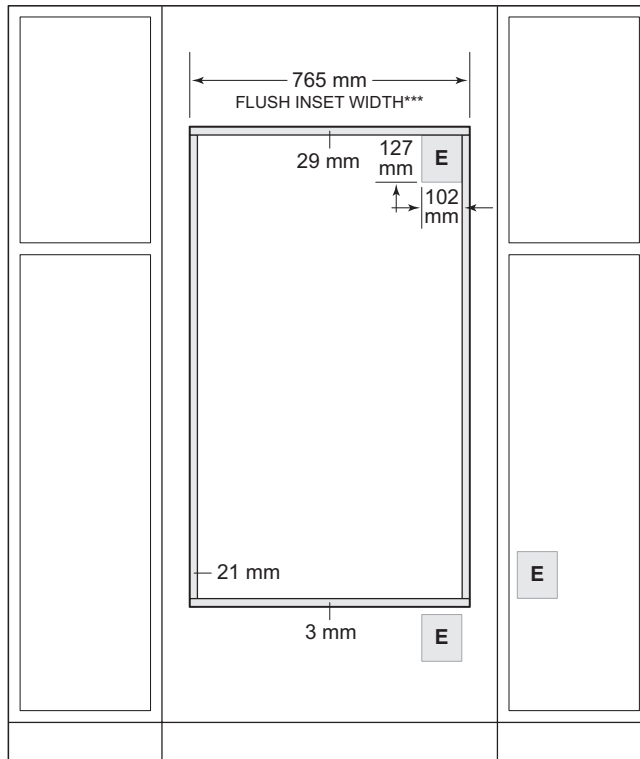

FRONT VIEW

*25 mm minimum depth. Shaded areas will be visible and should be finished to match cabinetry.

**22 mm for transitional, professional and contemporary stainless steel models and 25 mm for contemporary black glass model.

***Dimension provides minimum reveals.

NOTE: Location of electrical supply within opening may require additional cabinet depth.

M Series Single Oven

DUAL STANDARD INSTALLATION

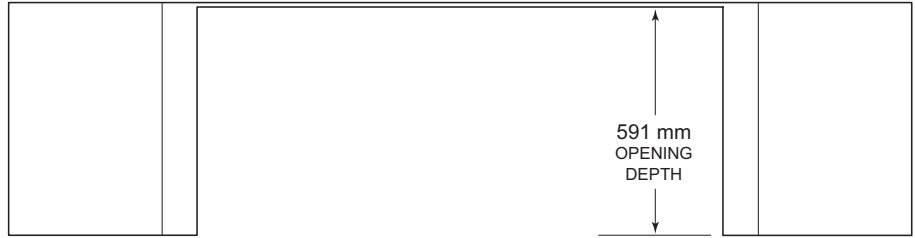

TOP VIEW

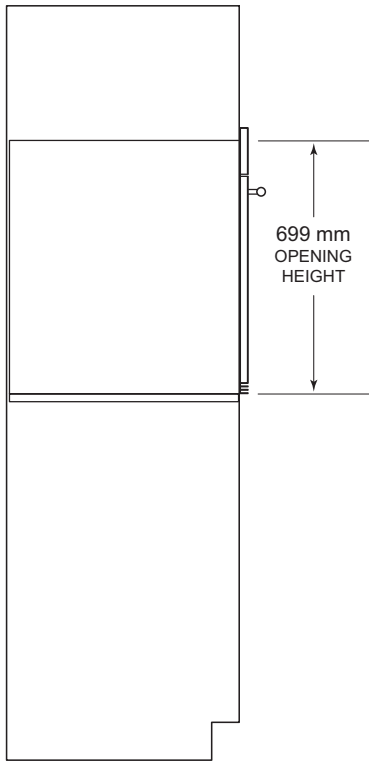

SIDE VIEW

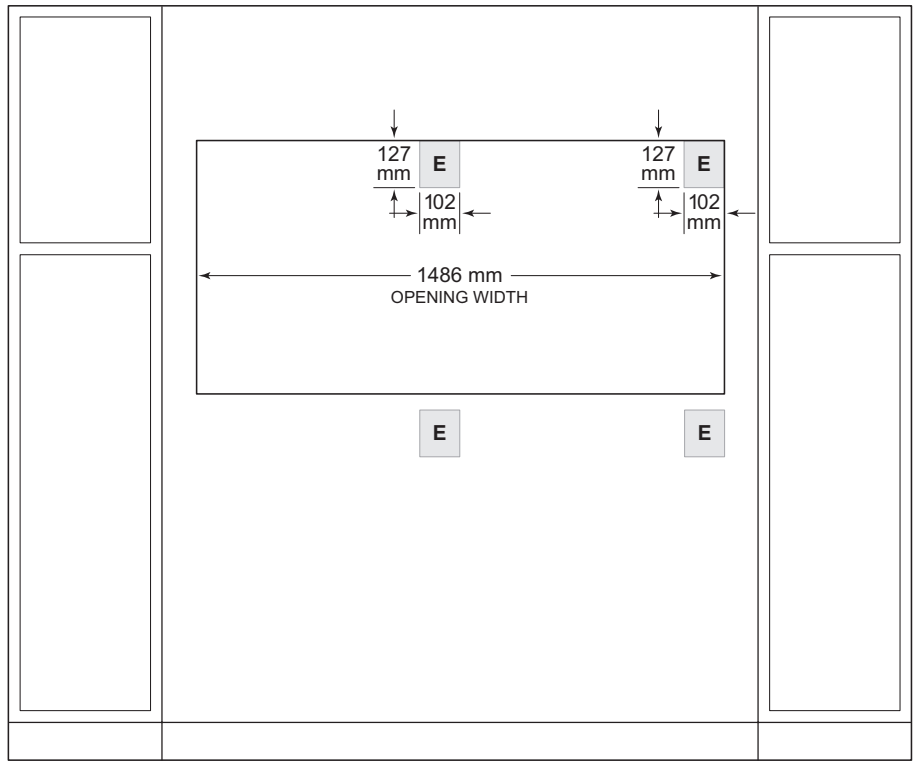

FRONT VIEW

NOTE: Location of electrical supply within opening may require additional cabinet depth. A dual installation kit is required for this installation.

M Series Single Oven

DUAL FLUSH INSET INSTALLATION

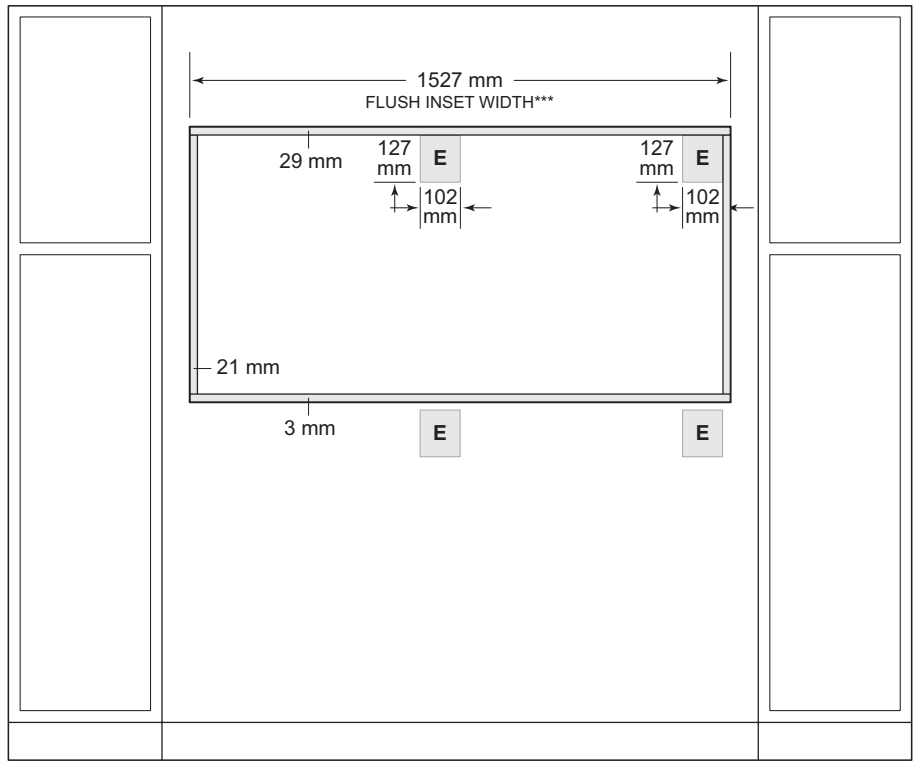
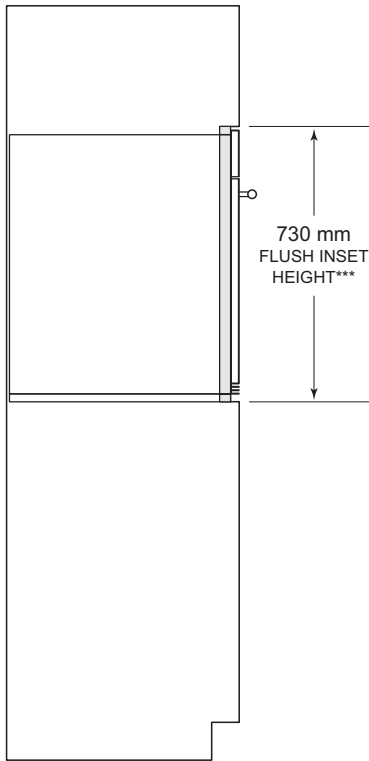

*25 mm minimum depth. Shaded areas will be visible and should be finished to match cabinetry.

**22 mm for transitional, professional and contemporary stainless steel models and 25 mm for contemporary black glass model.

***Dimension provides minimum reveals.

NOTE: Location of electrical supply within opening may require additional cabinet depth. A dual installation kit is required for this installation.

E Series Built-In Ovens

The Wolf E Series Convection Oven has two fans and four heating elements. Ten cooking modes allow you to select the one precisely suited to the dish you're preparing. The oven is self-cleaning. E Series Ovens are crafted of stainless steel. The handles match the rest of the Wolf cooking appliance offering, providing a more cohesive look. E Series Ovens can be installed in a standard or flush inset application.

E SERIES OVENS

TRANSITIONAL

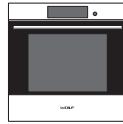

ICBSO2450TE/S/T

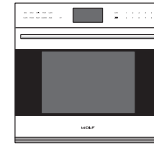

ICBSO3050TE/S/TH

PROFESSIONAL

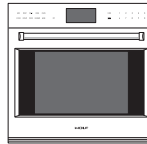

ICBSO3050PE/S/PH

60 cm E Series Oven

TRANSITIONAL

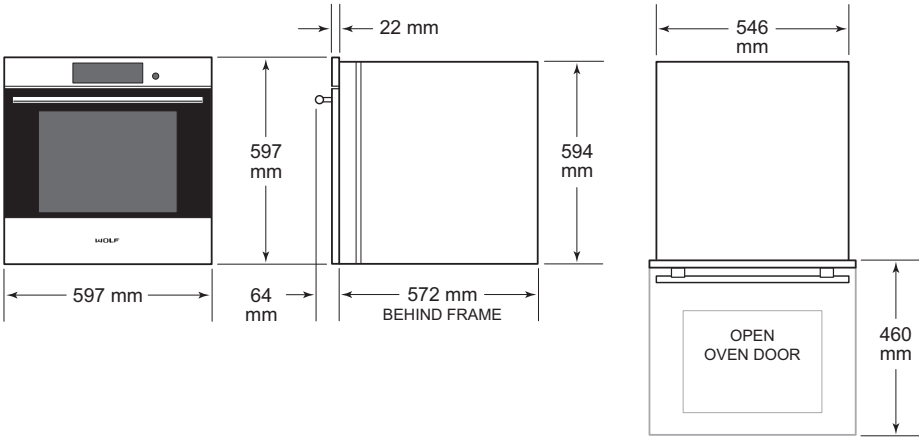

E Series Ovens

76 cm E Series Ovens

TRANSITIONAL

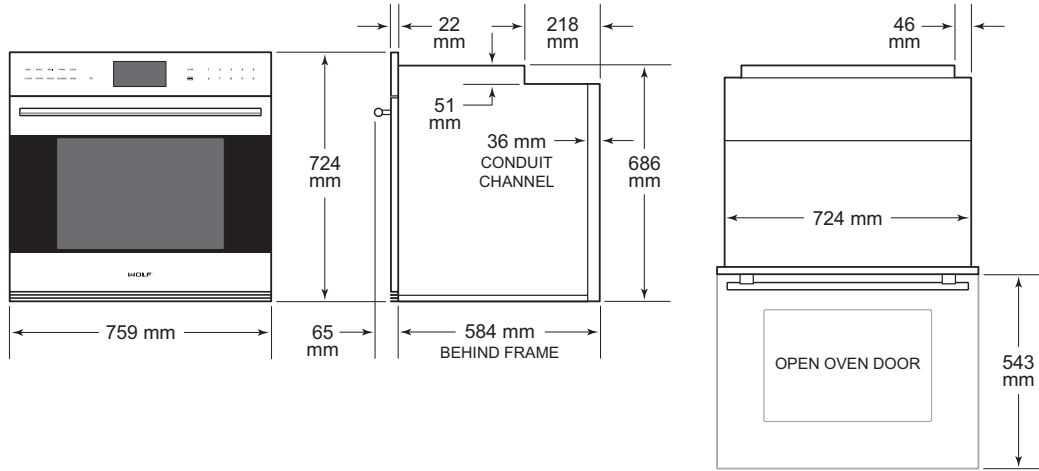

PROFESSIONAL

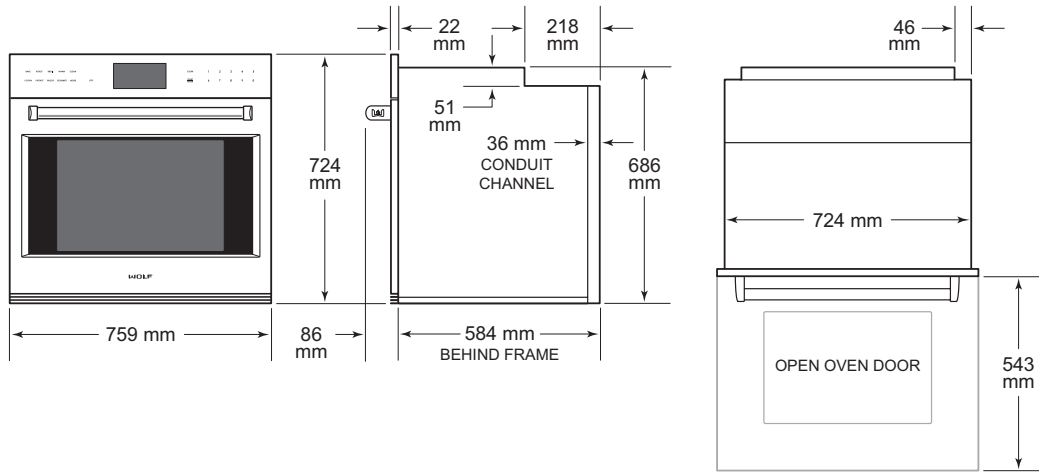

Planning Information

The E series oven can be installed in a standard or flush inset application. If a cooktop is installed above an oven, a minimum of 6 mm is required between the units. The location of the electrical supply within the oven opening may require additional cabinet depth.

Finish the edges of the opening. They may be visible when the door is open.

For standard installations, the face trim overlaps stiles and rails. Refer to the chart below.

For flush inset installations, a minimum 3 mm reveal is required on all sides. To ensure consistent reveals, each corner of the opening must be exactly 90°.

INSTALLATION REQUIREMENTS

BASE SUPPORT		MIN
60 cm Oven		68 kg
76 cm Oven		115 kg
TRIM OVERLAP		
	60 cm OVEN	76 cm OVEN
Top	3 mm	25 mm
Bottom	0 mm	0 mm
Sides	17 mm	18 mm

ELECTRICAL REQUIREMENTS—60 cm OVEN

Installation must comply with all applicable electrical codes and be properly grounded (earthed).

For ease of installation, the electrical supply for the oven should be placed in an adjacent cabinet within reach of the conduit. Performance may be compromised if the electrical supply is less than 230 volts.

The oven is supplied with a cable consisting of two hot lead conductors and a ground conductor. The wiring diagram covering the control circuit is provided with the oven.

ELECTRICAL REQUIREMENTS—60 cm OVEN

Electrical Supply	grounded, 230 VAC, 50 Hz
Service	16 amp dedicated circuit
Cabel Length	1.2 m
Total Amps	16
Max Connected Load	3.3 kW

ELECTRICAL REQUIREMENTS—76 cm OVEN

Installation must comply with all applicable electrical codes and be properly grounded (earthed).

Locate the electrical supply flush with the back wall and within the shaded area shown in the illustrations on the following pages. For ease of installation, the electrical supply for the oven can be placed in an adjacent cabinet within reach of the conduit. Performance may be compromised if the electrical supply is less than 240 volts.

The oven is supplied with a single phase and 3-phase convertible power inlet box. The wiring diagram covering the control circuit is provided with the oven.

ELECTRICAL REQUIREMENTS—76 cm OVEN

ELECTRICAL SUPPLY

Single Phase	220–240 V AC, 50/60 Hz
3-Phase	380–415 V AC, 50 Hz
Maximum Connected Load	4.8 kW
Total Amps	20
Maximum Amps per Line	15

60 cm E Series Oven

STANDARD INSTALLATION

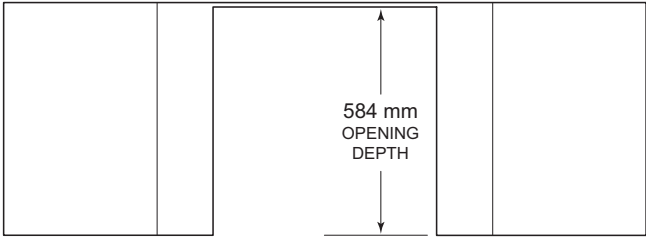

TOP VIEW

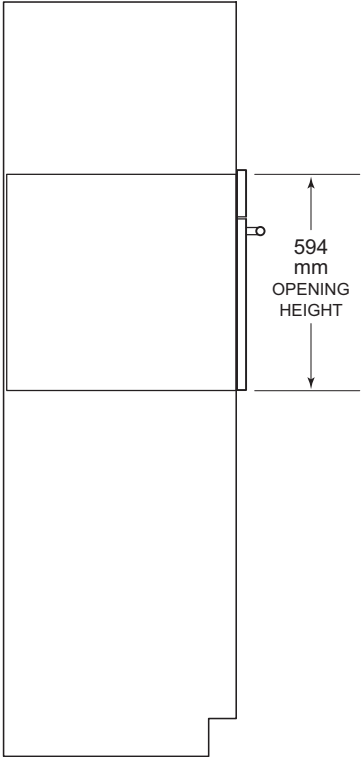

SIDE VIEW

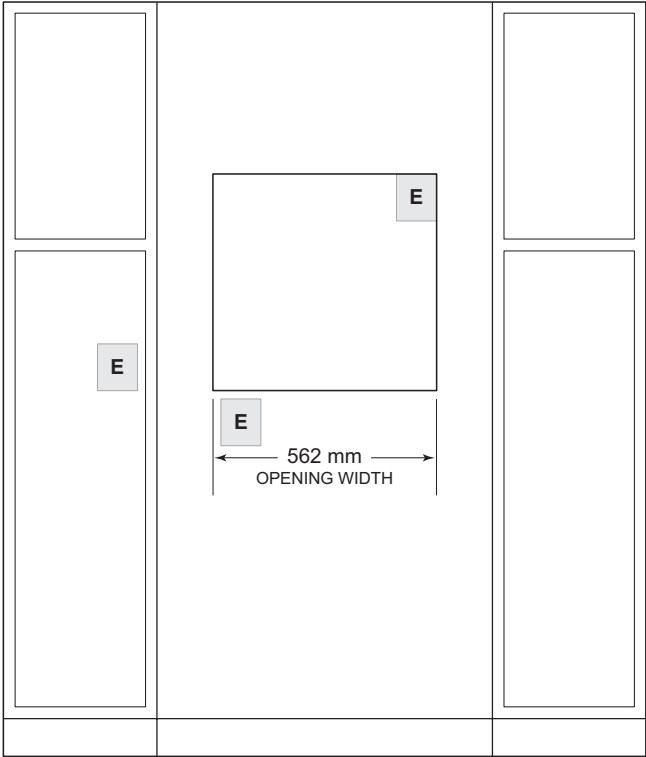

FRONT VIEW

NOTE: Location of electrical supply within opening may require additional cabinet depth.

60 cm E Series Oven

FLUSH INSET INSTALLATION

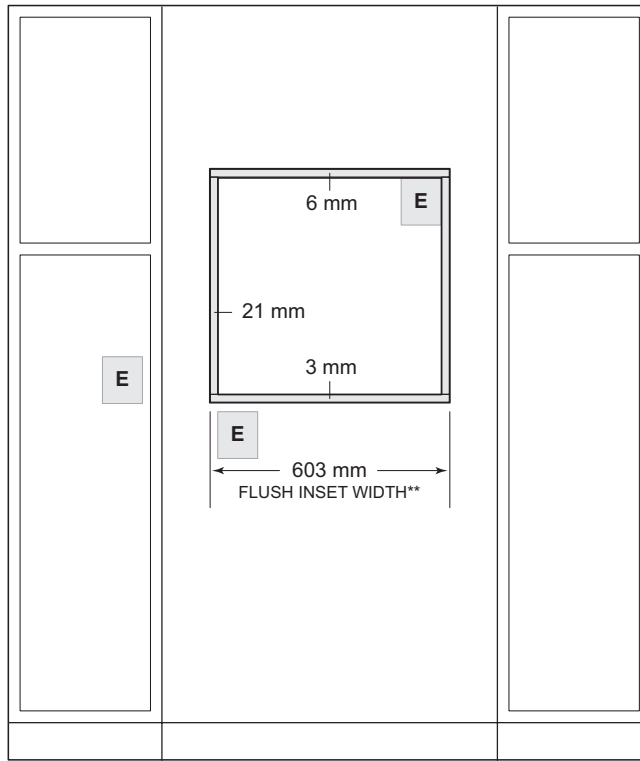
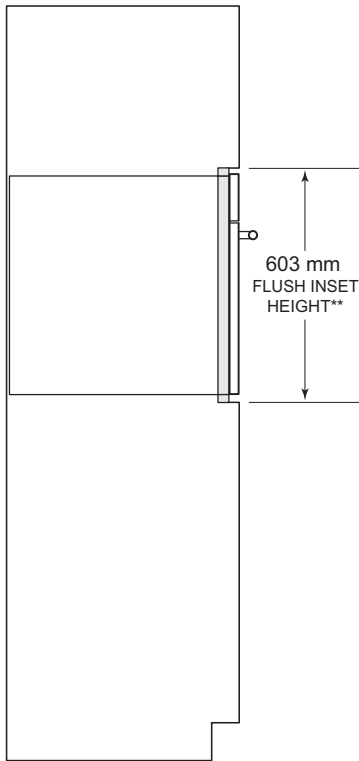
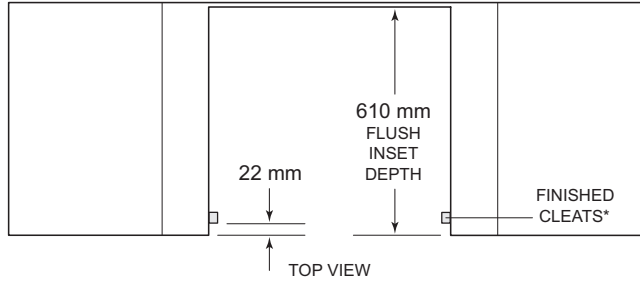

SIDE VIEW

FRONT VIEW

*Will be visible and should be finished to match cabinetry.

**Dimension provides minimum reveals.

NOTE: Location of electrical supply within opening may require additional cabinet depth.

76 cm E Series Oven

STANDARD INSTALLATION

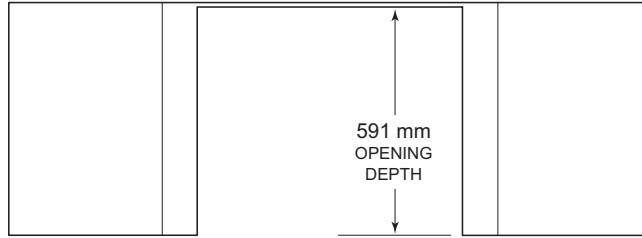

TOP VIEW

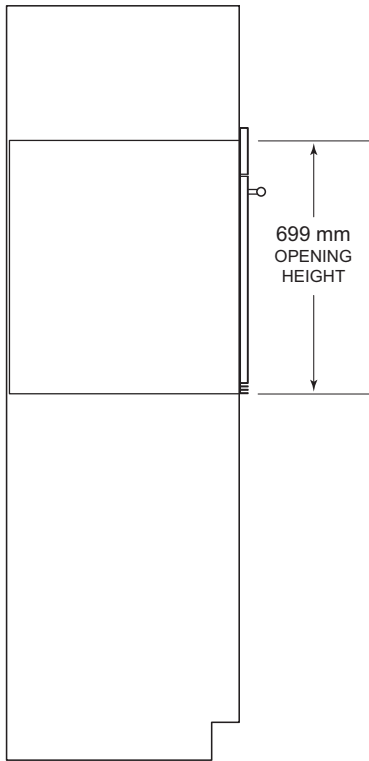

SIDE VIEW

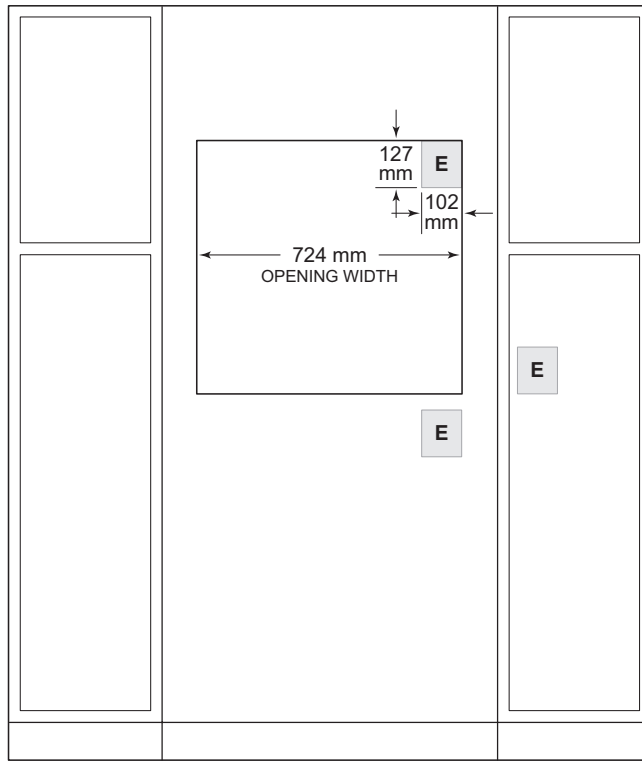

FRONT VIEW

NOTE: Location of electrical supply within opening may require additional cabinet depth.

76 cm E Series Oven

FLUSH INSET INSTALLATION

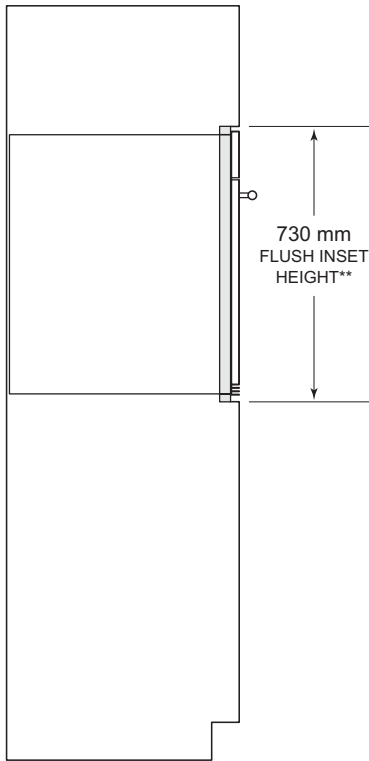
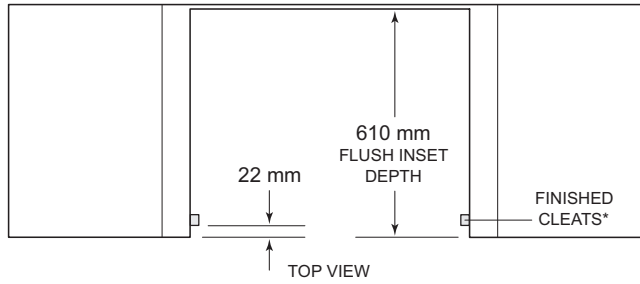

SIDE VIEW

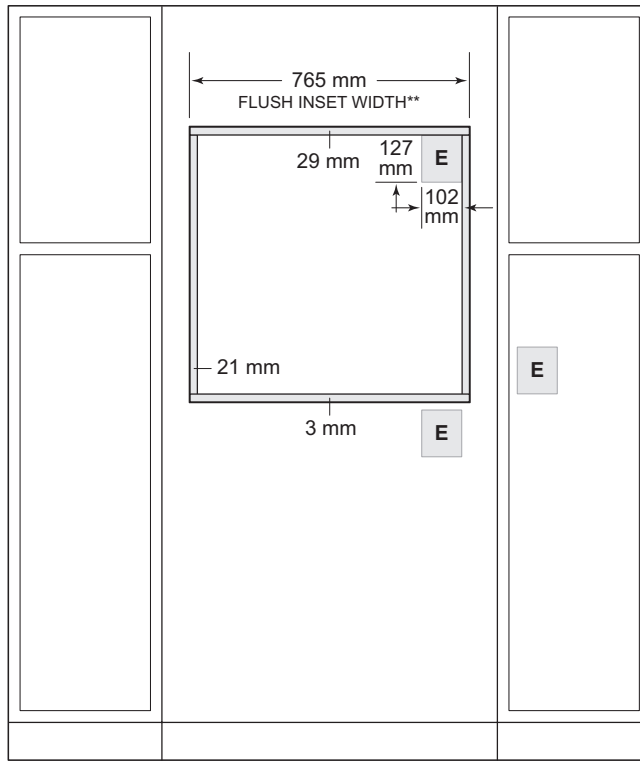

FRONT VIEW

*Shaded areas will be visible and should be finished to match cabinetry.

**Dimension provides minimum reveals.

NOTE: Location of electrical supply within opening may require additional cabinet depth.

Convection Steam Ovens

The legacy of the “combination oven” goes back decades, to innovative chefs in America and Europe who embraced the combination of air movement with superheated steam to achieve superior results—from breads and roasts to delicate fishes, seafood, and vegetables. Wolf combines the benefits of convection and steam for the most innovative steam oven on the market today. Virtually any dish prepared in a conventional oven, range, or microwave can also be prepared in the Wolf Convection Steam Oven—with more control. Two widths and three distinct styles compliment the look of Wolf ovens, ranges, and cooktops. Convection Steam Ovens can be installed in a standard or flush inset application.

CONVECTION STEAM OVENS

TRANSITIONAL

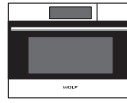

ICBCSO2450TE/S/T
ICBCSOP2450TE/S/T

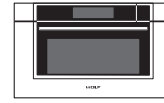

ICBCSO3050TM/S/T

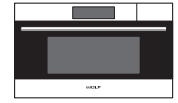

ICBCSO3050TE/S/T

PROFESSIONAL

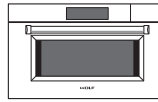

ICBCSO3050PM/S/P

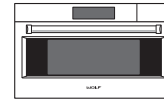

ICBCSO3050PE/S/P

CONTEMPORARY



ICBCSO3050CM/B/T

CONTEMPORARY HANDLELESS

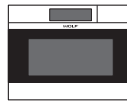

ICBCSO2450CM/S



ICBCSO3050CM/S



ICBCSO3050CM/B

Convection Steam Ovens

Convection Steam Ovens

TRANSITIONAL

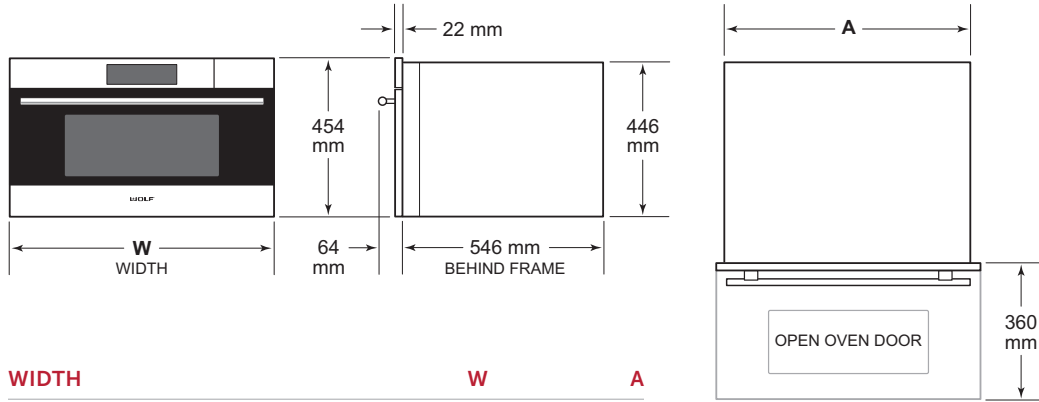

WIDTH	W	A
60 cm Transitional	597 mm	546 mm
76 cm Transitional	759 mm	721 mm

PROFESSIONAL

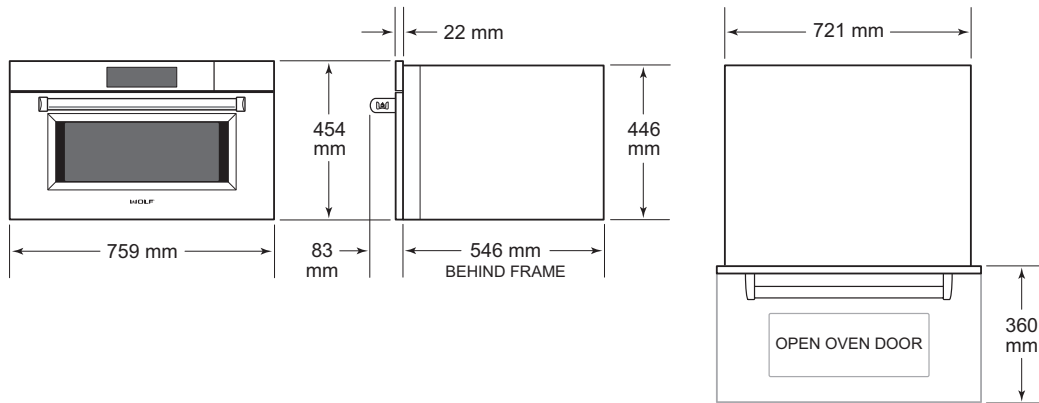

Convection Steam Ovens

Convection Steam Ovens

CONTEMPORARY

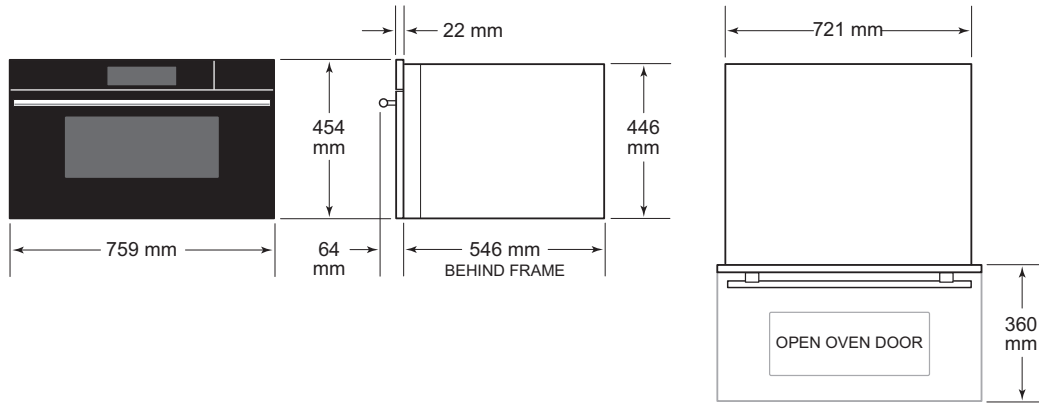

CONTEMPORARY HANDLELESS

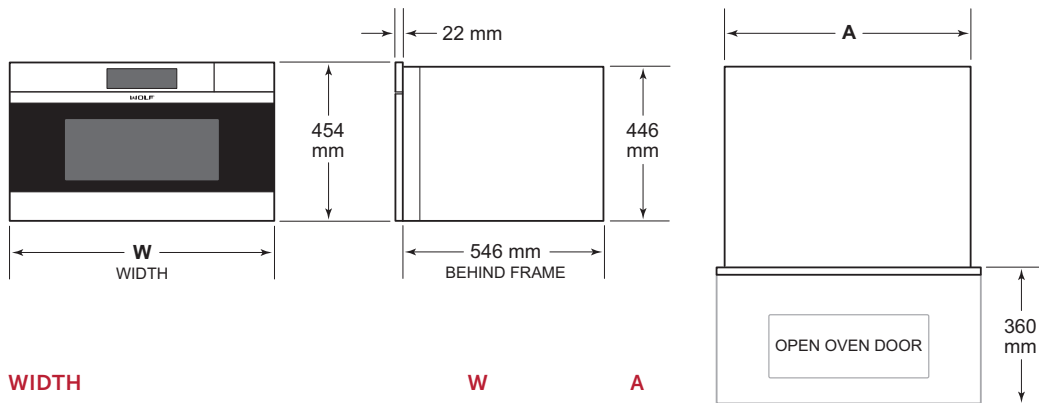

WIDTH	W	A
60 cm Contemporary Handleless	597 mm	546 mm
76 cm Contemporary Handleless	759 mm	721 mm

Planning Information

The Convection Steam Oven can be installed in a standard or flush inset application. The back of the base support must be open for water and drain line accessibility and routing. Refer to the illustration below.

Finish the edges of the opening. They may be visible when the door is open.

For standard installations, the face trim overlaps stiles and rails. Refer to the chart below.

For flush inset installations, a minimum 3 mm reveal is required on all sides. To ensure consistent reveals, each corner of the opening must be exactly 90°.

INSTALLATION REQUIREMENTS

Minimum Base Support 68 kg

TRIM OVERLAP	60 cm OVEN	76 cm OVEN
Top	5 mm	5 mm
Bottom	0 mm	0 mm
Sides	22 mm	16 mm

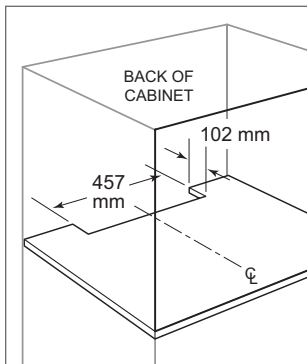

Base support

ELECTRICAL REQUIREMENTS

Installation must comply with all applicable electrical codes and be properly grounded (earthed).

For ease of installation, the electrical supply for the oven should be placed in an adjacent cabinet within reach of the conduit.

Performance may be compromised if the electrical supply is less than 230 volts.

The oven is supplied with a cable consisting of two hot lead conductors and a ground conductor. The wiring diagram covering the control circuit is provided with the oven.

ELECTRICAL REQUIREMENTS

Electrical Supply	grounded, 230 VAC, 50 Hz
Service	16 amp dedicated circuit
Cable Length	1.2 m
Total Amps	16
Max Connected Load	3.7 kW

Plumbing Requirements

MODEL ICBCSOP2450TE/S/T

IMPORTANT NOTE: The unit needs minerals in the water to operate. Do not connect to a filtered water supply.

Installation must comply with all applicable plumbing codes.

IMPORTANT NOTE: The drain connection must be able to withstand temperatures up to 55°C.

The drain tube connection must be a minimum 51 mm below the unit and a minimum 102 mm from the floor. Locate the drain and water connections below the unit or in an adjacent cabinet. Any opening into the adjacent cabinet must meet the following: the longest dimension of the opening shall not be more than 38 mm. The edges of the opening must be smooth and round.

IMPORTANT NOTE: The drain location can vary, but must be within reach of the corrugated tubing. Do not extend or reduced the drain tubing. A drain line high loop is required. Refer to the illustrations below.

Connect the water supply to a cold water house supply with an easily accessible shut-off valve between the supply and the unit.

PLUMBING REQUIREMENTS

Water Connection	2 m braided tubing with 3/8" female compression fitting
Drain Connection	3 m corrugated tubing with 22 mm outlet
Pressure	0.1–1.0 MPa

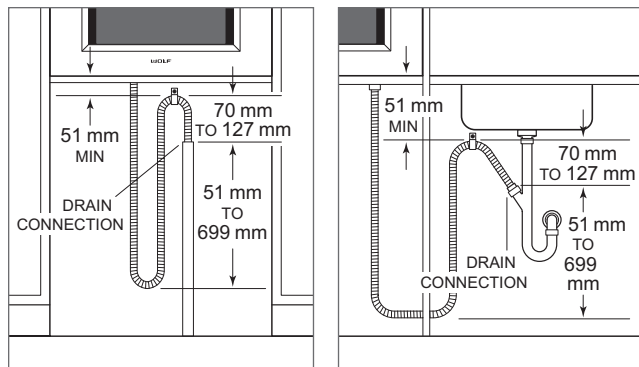

Drain connection A

Drain connection B

Convection Steam Ovens

Convection Steam Oven

STANDARD INSTALLATION

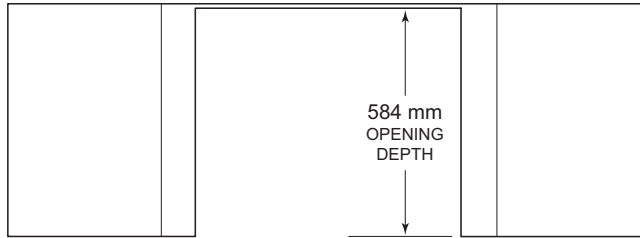

TOP VIEW

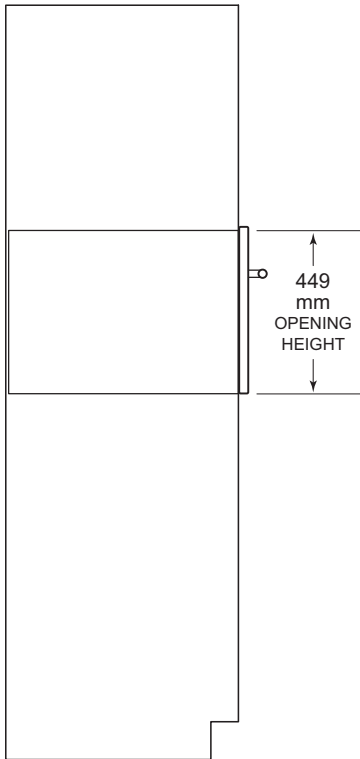

SIDE VIEW

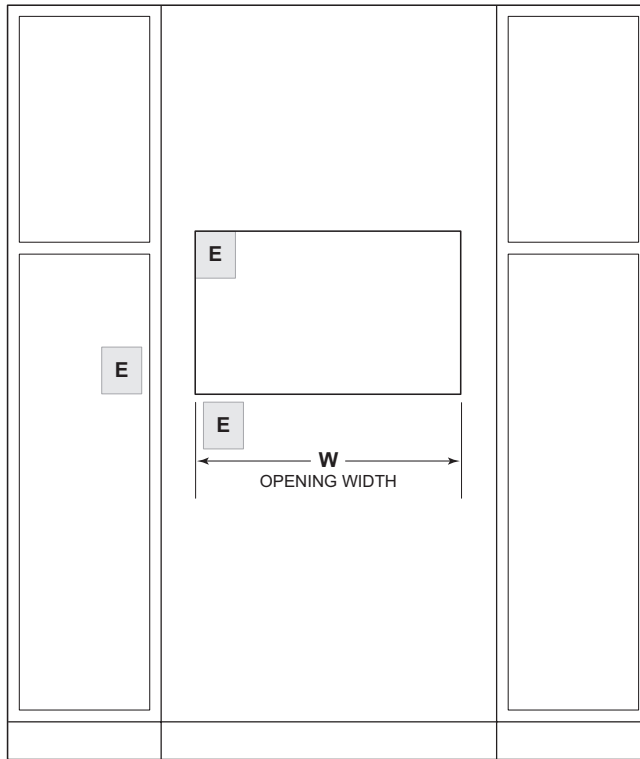

FRONT VIEW

NOTE: Location of electrical supply within opening may require additional cabinet depth.

OPENING WIDTH	W
60 cm Model	553 mm
76 cm Model	727 mm

Convection Steam Ovens

Convection Steam Oven

FLUSH INSET INSTALLATION

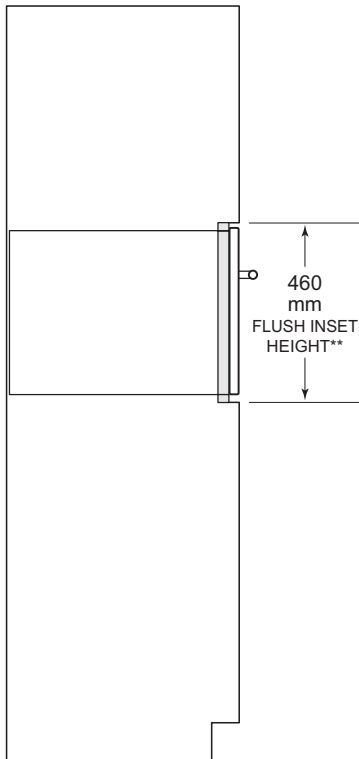
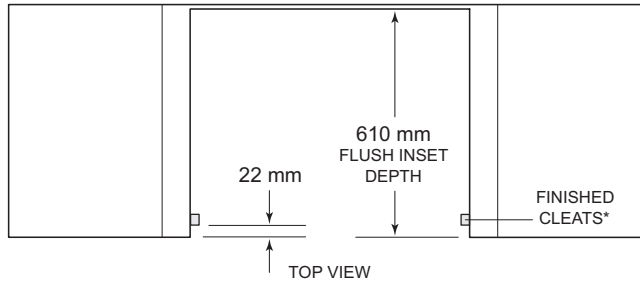

SIDE VIEW

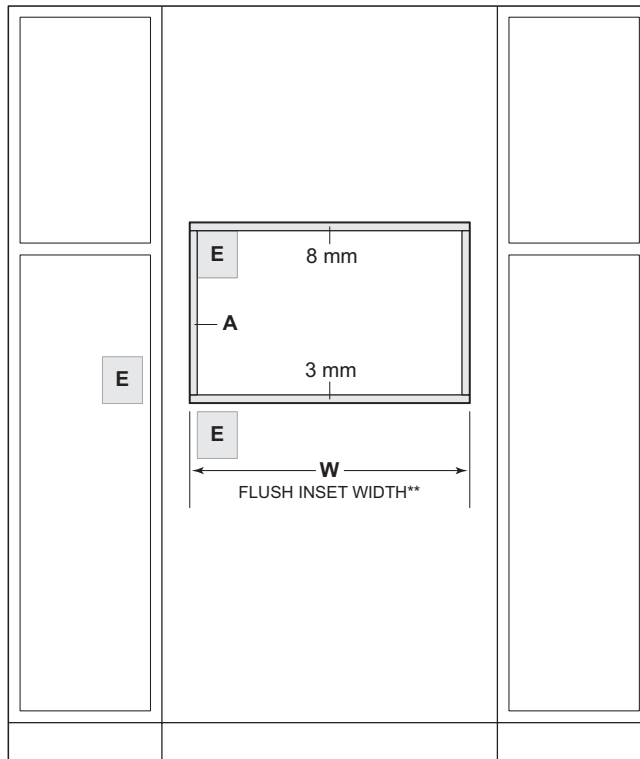

FRONT VIEW

*Will be visible and should be finished to match cabinetry.

**Dimension provides minimum reveals.

NOTE: Location of electrical supply within opening may require additional cabinet depth.

FLUSH INSET WIDTH	W	A
60 cm Model	603 mm	25 mm
76 cm Model	765 mm	19 mm

Speed Ovens

The Wolf Speed Oven has features that make fast meals better meals. Available in 60 cm and 76 cm widths, they are designed to match Wolf transitional, professional, and contemporary products. The Speed Oven can be installed in a standard or flush inset application.

SPEED OVENS

TRANSITIONAL

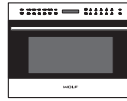

ICBSPO24TE/S/TH

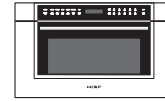

ICBSPO30TM/S/TH

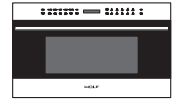

ICBSPO30TE/S/TH

PROFESSIONAL

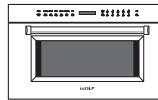

ICBSPO30PM/S/PH

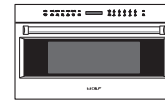

ICBSPO30PE/S/PH

CONTEMPORARY



ICBSPO30CM/B/TH

Speed Ovens

TRANSITIONAL

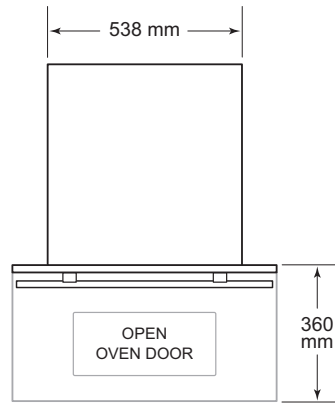
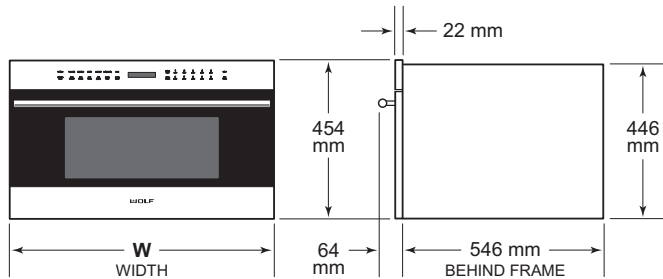

WIDTH	W
60 cm Transitional	597 mm
76 cm Transitional	759 mm

PROFESSIONAL

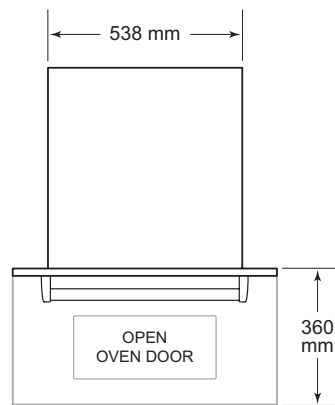
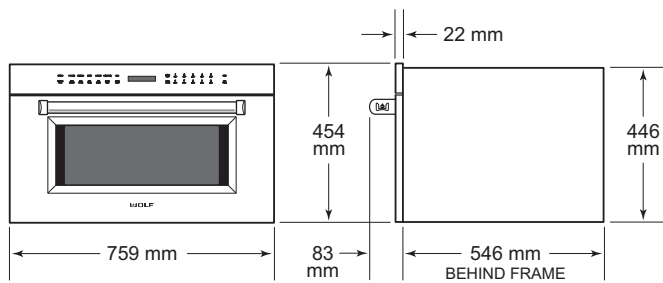

CONTEMPORARY

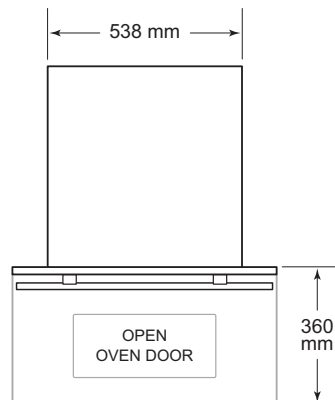
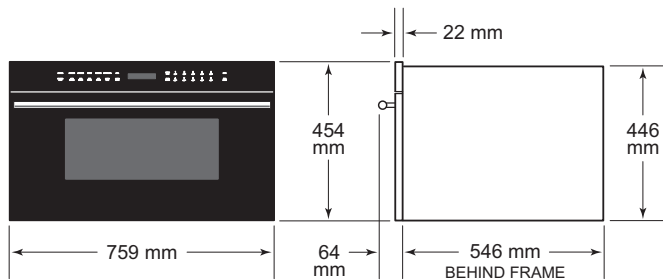

Planning Information

The Speed Oven can be installed in a standard or flush inset application.

Finish the edges of the opening. They may be visible when the door is open.

For standard installations, the face trim will overlap stiles and rails. Refer to the chart below.

For flush inset installations, a minimum 3 mm reveal is required on all sides. To ensure consistent reveals, each corner of the opening must be exactly 90°.

If the Speed Oven is installed above or below a Wolf E Series Oven in a flush inset application, a 6 mm reveal is required.

INSTALLATION REQUIREMENTS

BASE SUPPORT	MIN
60 cm Model	57 kg
76 cm Model	57 kg

TRIM OVERLAP	60 cm MODEL	76 cm MODEL
Top	5 mm	5 mm
Bottom	0 mm	0 mm
Sides	18 mm	98 mm

ELECTRICAL REQUIREMENTS

Installation must comply with all applicable electrical codes and be properly grounded (earthed).

Locate the electrical supply as shown in the illustrations on the following pages. A separate circuit servicing only this appliance is required. A ground fault circuit interrupter (GFCI) is not recommended and may cause interruption of operation.

Performance may be compromised if the electrical supply is less than 220 volts.

ELECTRICAL REQUIREMENTS

Electrical Supply	220-240 V AC, 50 Hz
Service	2800 W
Receptacle	grounding-type (earthed)
Power Cord	1.2 m

Speed Oven

STANDARD INSTALLATION

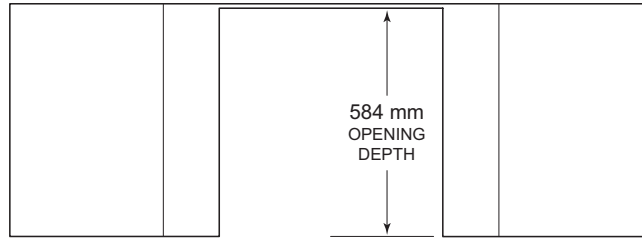

TOP VIEW

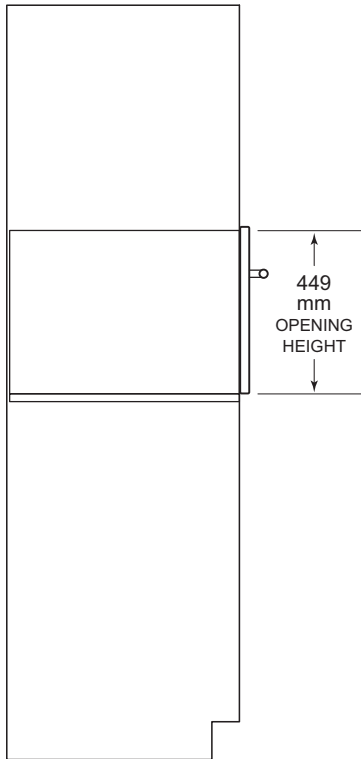

SIDE VIEW

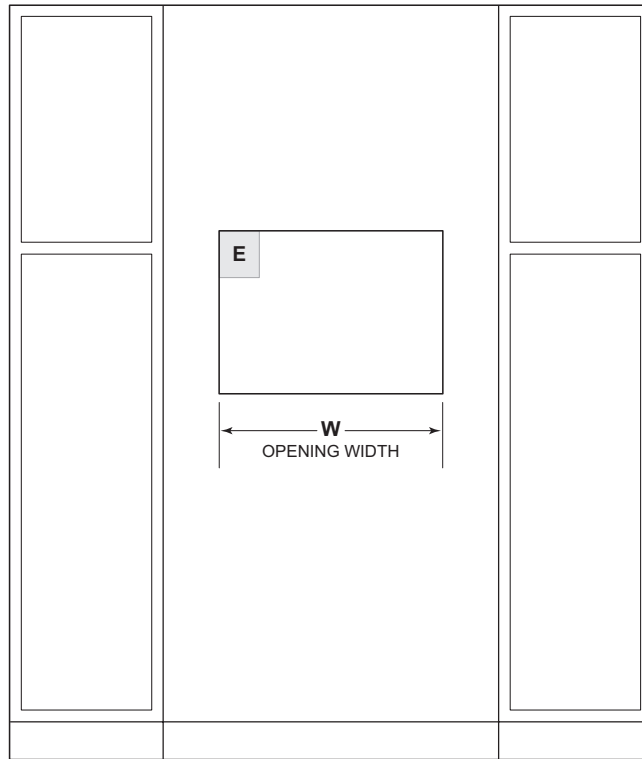

FRONT VIEW

NOTE: 60 cm and 76 cm models require the same opening dimensions.

OPENING WIDTH	W
60 cm Model	562 mm
76 cm Model	562 mm

Speed Oven

FLUSH INSET INSTALLATION

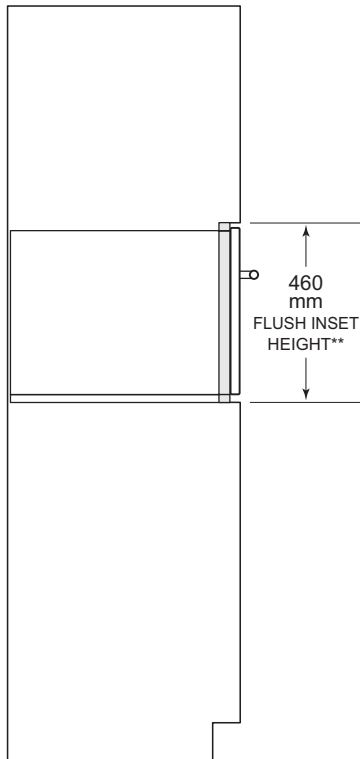
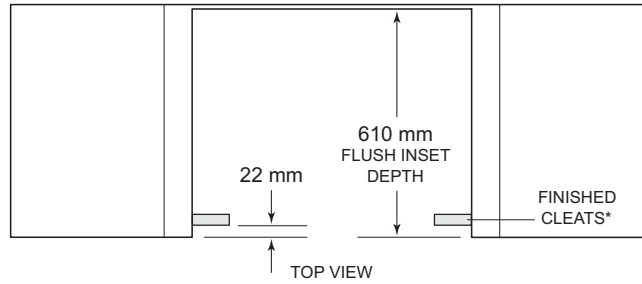

SIDE VIEW

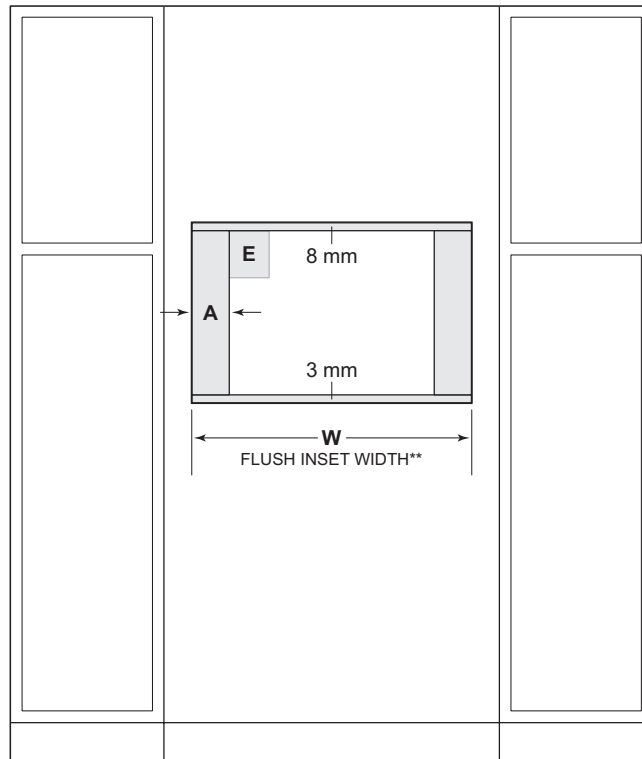

FRONT VIEW

*Will be visible and should be finished to match cabinetry.

**Dimension provides minimum reveals.

FLUSH INSET WIDTH	W	A
60 cm Model	603 mm	21 mm
76 cm Model	765 mm	102 mm

Warming Drawers

Wolf Warming Drawers are designed to take care of prepared foods until it is time to serve them. You can adjust the temperature, keeping moist foods moist and crisp foods crisp. Warming Drawers are ideal for proofing dough. Drawer fronts are available to match the look of Wolf Ovens and Sealed Burner Rangetops. The integrated drawer front allows for a custom panel and handle.

WARMING DRAWER FRONTS

M SERIES



TRANSITIONAL

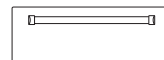

PROFESSIONAL



CONTEMPORARY

E SERIES

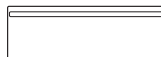

TRANSITIONAL

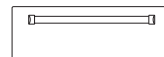

PROFESSIONAL

INTEGRATED



CUSTOM PANEL

Warming Drawers

DRAWER FRONT OPTIONS

Wolf Warming Drawer fronts allow for many design options, but the Warming Drawer itself will be the same for all applications. A panel mounting kit is required when installing a custom panel. The panel mounting kit is available through an authorized Wolf dealer.

The 51 mm thick drawer front is designed to be installed below a Sealed Burner Rangetop, so the panel aligns properly with the front of the rangetop. Dimensions for the Warming Drawer remain the same, even though the drawer front may be wider to match a Wolf 91 cm Oven or Sealed Burner Rangetop.

DIMENSIONS

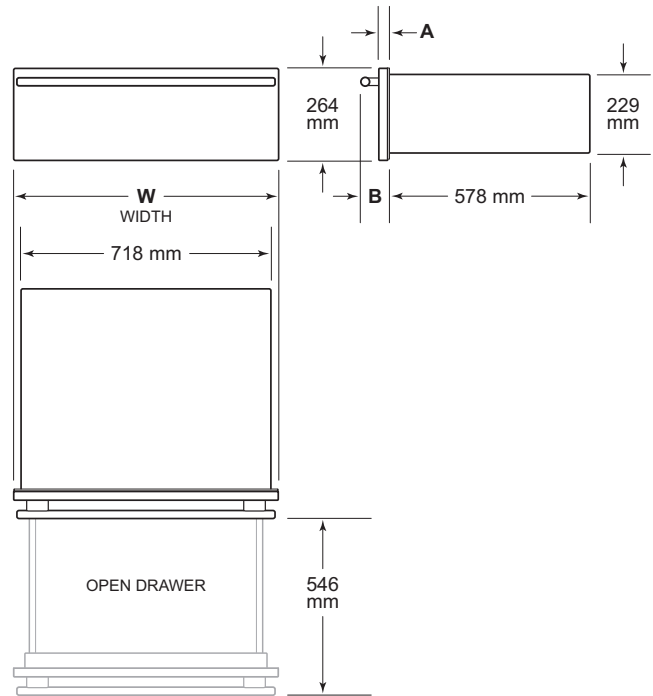

DRAWER FRONT

MODEL	W
76 cm Drawer Front	759 mm
91 cm Drawer Front	911 mm

M SERIES	A	B
Transitional / Professional	22 mm	83 mm
Contemporary	25 mm	86 mm

E SERIES	A	B
Transitional / Professional	29 mm	89 mm
Professional (51 mm thick)	54 mm	114 mm

INTEGRATED DRAWER FRONT

CUSTOM PANEL	W	H	D
Typical Dimensions	759 mm	264 mm	19 mm
Min Thickness			16 mm

Planning Information

The Warming Drawer must be installed with a Wolf drawer front, available through an authorized Wolf dealer. Specific installation instructions are included with the drawer front.

The Warming Drawer can be installed in a standard or flush inset application.

For a standard installation, the drawer collar and front panel sit proud of the cabinet face frame. A recessed installation requires the cabinetry be recessed by 5 mm so the collar is flush with the cabinet face frame but the drawer front will sit proud. A flush inset installation requires the drawer collar and front panel be recessed to be flush with surrounding cabinetry. Refer to the illustrations on the following pages for minimum cabinet dimensions for your specific installation.

Finish the edges of the opening. They may be visible when the drawer is open.

For standard installations, the face trim will overlap stiles and rails. Refer to the chart below.

For flush inset installations, a minimum 3 mm reveal is required on all sides. To ensure consistent reveals, each corner of the opening must be exactly 90°.

INSTALLATION REQUIREMENTS

Minimum Base Support	90 kg
Trim Overlap (top, bottom, sides)	16 mm

ELECTRICAL REQUIREMENTS

Installation must comply with all applicable electrical codes and be properly grounded (earthed).

Locate the electrical supply flush with the back wall and within the shaded area shown in the illustrations on the following pages. For ease of installation, the electrical supply for the Warming Drawer can be placed in an adjacent cabinet within reach of the power cord.

ELECTRICAL REQUIREMENTS

Electrical Supply	220-240 V AC, 50/60 Hz
Service	850 W
Receptacle	grounding-type (earthed)
Power Cord	.9 m

Warming Drawer

STANDARD INSTALLATION

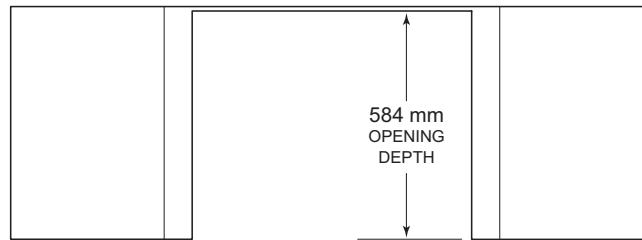

TOP VIEW

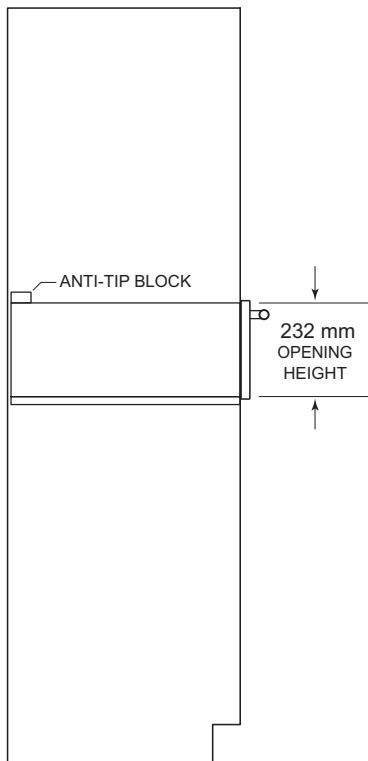

SIDE VIEW

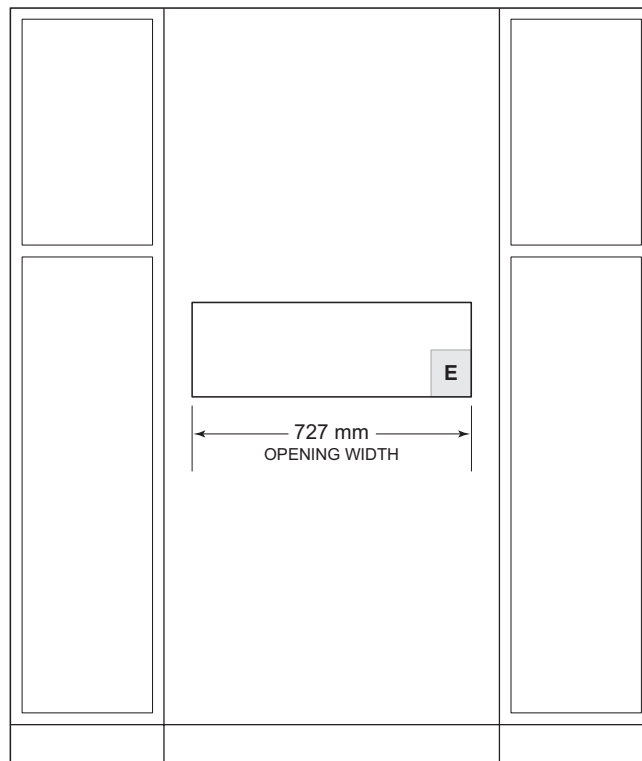

FRONT VIEW

NOTE: Location of electrical supply within opening may require additional cabinet depth.

Induction Cooktops

Almost instantaneous temperature response. Practically no wasted heat. Induction cooking has been popular among European chefs and homeowners for decades. Now Wolf leads the way in bringing this remarkable technology to North American kitchens. Its secret is magnetism. Electromagnetic elements cause iron and magnetic stainless cookware to heat up instantly and with perfectly distributed heat. Heat generation stops the instant you turn off the element or remove the pan. The cooktop's surface remains cool. Your kitchen stays cooler too. Transitional models have a brushed stainless steel trim. Contemporary models can be mounted flush with the countertop.

The following models have the same stainless steel frame as our module cooktops for paired installations: ICBCI243TF/S, ICBCI304TF/S, and ICBCI365TF/S.

INDUCTION COOKTOPS

TRANSITIONAL

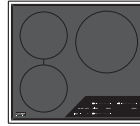

ICBCI243TF/S

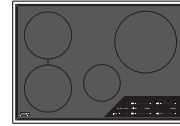

ICBCI304TF/S

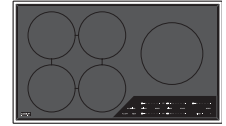

ICBCI365TF/S

CONTEMPORARY

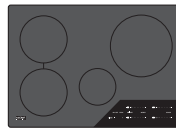

ICBCI304C/B

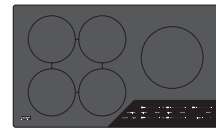

ICBCI365C/B



ICBCI30460C/B



ICBCI36560C/B

Induction Cooktops

60 cm TRANSITIONAL

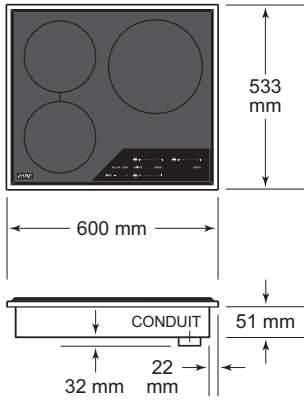

76 cm TRANSITIONAL

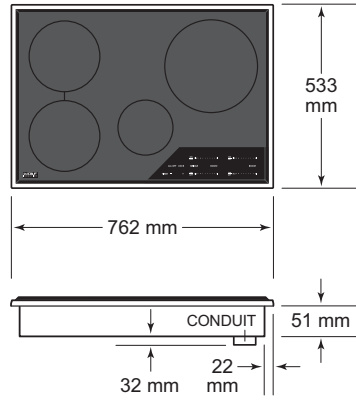

91 cm TRANSITIONAL

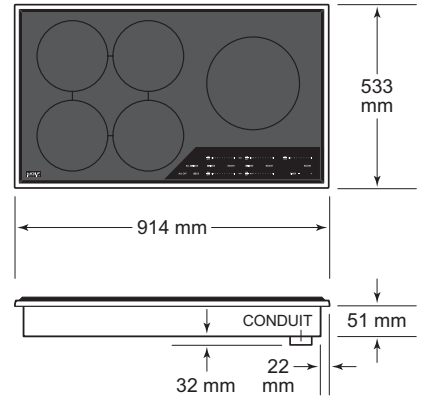

76 cm CONTEMPORARY

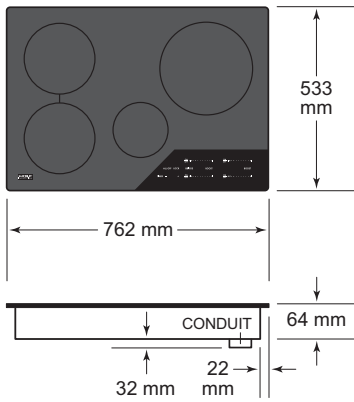

91 cm CONTEMPORARY

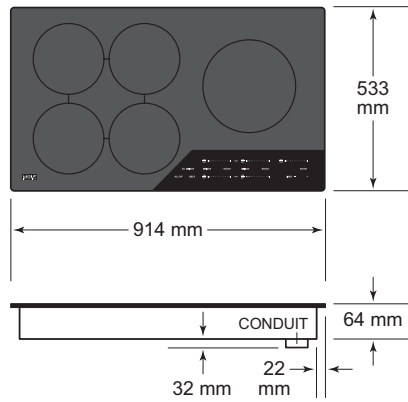

76 cm CONTEMPORARY

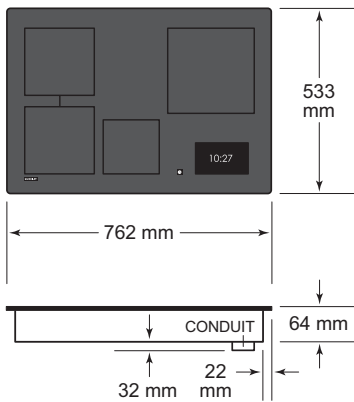

91 cm CONTEMPORARY

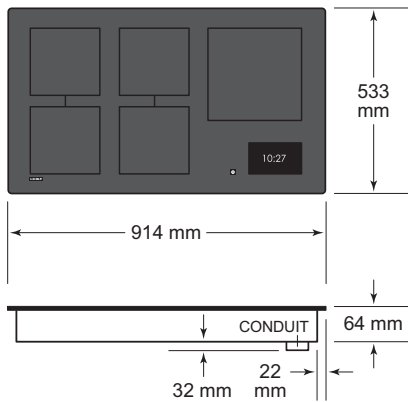

Planning Information

A minimum height clearance of 159 mm is required from the top of the countertop to any combustible surface directly below the cooktop.

Contemporary Induction Cooktops can be mounted flush with the top of the countertop, or as a frameless standard installation sitting on top of the countertop surface. If the cooktop is to be mounted flush with the countertop, a recessed area surrounding the cooktop cutout must be provided.

IMPORTANT NOTE: Flush mount installations are intended for granite, solid surface, or stone countertop surfaces only.

ELECTRICAL REQUIREMENTS

Installation must comply with all applicable electrical codes and be properly grounded (earthed).

Locate the electrical supply as shown in the illustrations on the following pages. A separate circuit servicing only this appliance is required.

Performance may be compromised if the electrical supply is less than 220 volts.

The cooktop is supplied with a single phase and 3-phase convertible power inlet box.

ELECTRICAL REQUIREMENTS

ELECTRICAL SUPPLY

Single Phase	220–240 V AC, 50/60 Hz
3-Phase	380–415 V AC, 50 Hz

TOTAL AMPS	SINGLE PHASE	3-PHASE
60 cm Cooktop	30	16
76 cm Cooktop	32	16
91 cm Cooktop	48	16

Induction Cooktops

60 cm / 76 cm / 91 cm Induction Cooktop

STANDARD INSTALLATION

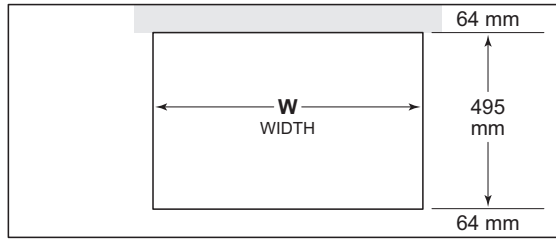

COUNTERTOP CUTOUT

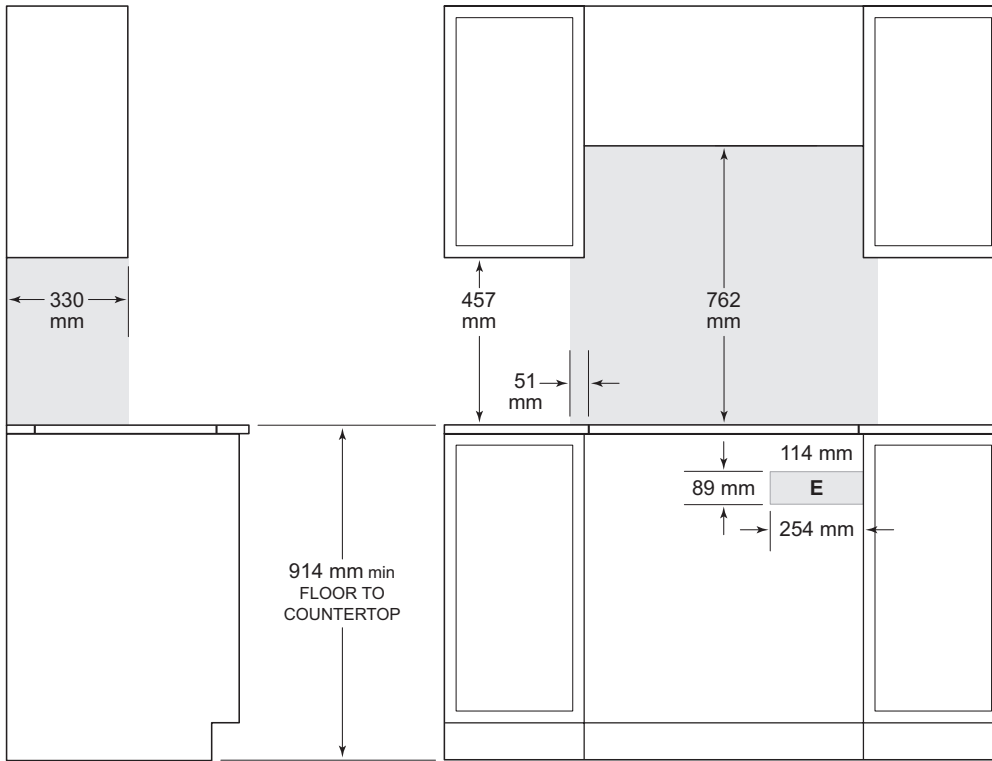

SIDE VIEW

FRONT VIEW

*NOTE: Shaded area above countertop indicates minimum clearance to combustible surfaces, combustible materials cannot be located within this area.
Electrical supply location only applies to installations with built-in oven.*

CUTOUT WIDTH	W
60 cm Cooktop	562 mm
76 cm Cooktop	737 mm
91 cm Cooktop	889 mm

Induction Cooktops

76 cm / 91 cm Induction Cooktop

FLUSH INSTALLATION

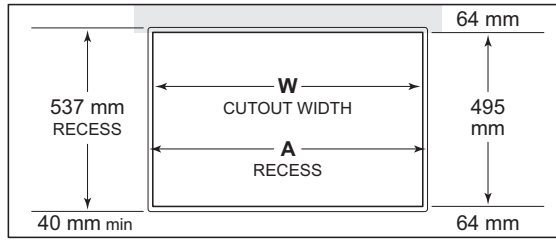
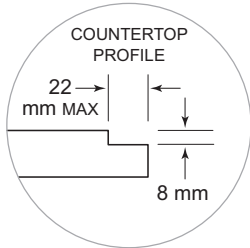

COUNTERTOP CUTOUT

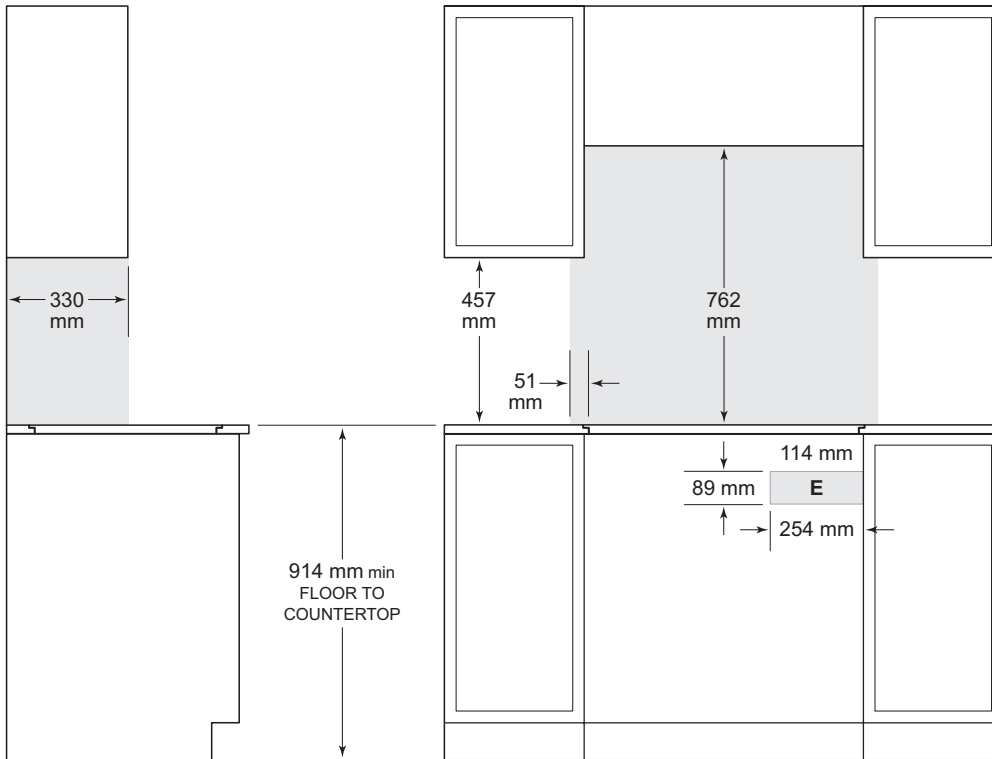

SIDE VIEW

FRONT VIEW

*NOTE: Shaded area above countertop indicates minimum clearance to combustible surfaces, combustible materials cannot be located within this area.
Electrical supply location only applies to installations with built-in oven.
Outside corner radius 11 mm.*

CUTOUT WIDTH	W	A
76 cm Cooktop	737 mm	765 mm
91 cm Cooktop	889 mm	918 mm

Gas Cooktops

Like their oven counterparts, the new generation of Wolf Gas Cooktops features two new looks—transitional and professional. New performance enhancements make delicious results even more of a certainty than ever. Multiple sizes, choice of knob colors, and distinctly different grates—the new Gas Cooktops offer exceptional design flexibility.

GAS COOKTOPS

TRANSITIONAL

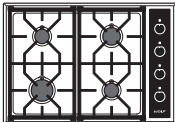

ICBCG304T/S



ICBCG365T/S

PROFESSIONAL



ICBCG304P/S



ICBCG365P/S

Gas Cooktops

76 cm TRANSITIONAL

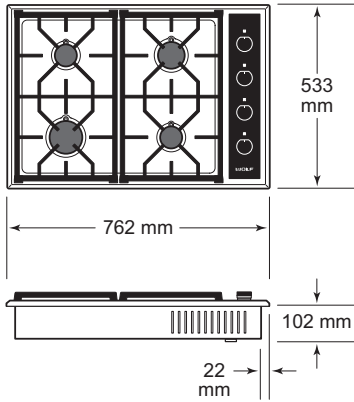

91 cm TRANSITIONAL

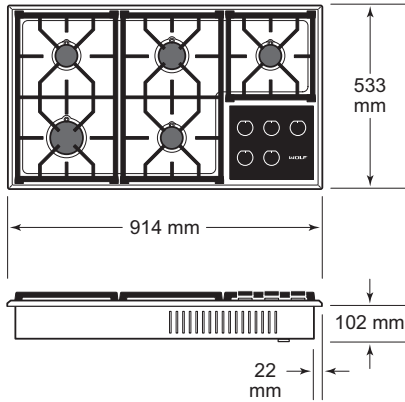

76 cm PROFESSIONAL

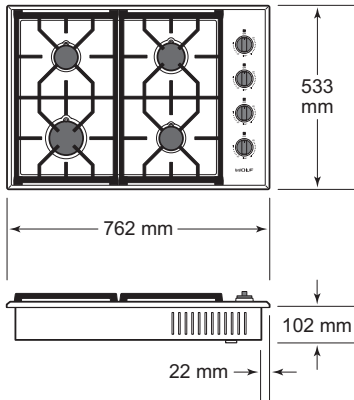

91 cm PROFESSIONAL

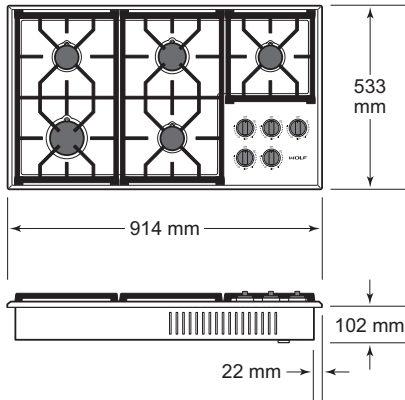

Planning Information

A minimum 51 mm is required from the bottom of the cooktop to combustible materials. If a cooktop is installed above an oven, a minimum of 6 mm is required between the units.

ELECTRICAL REQUIREMENTS

Installation must comply with all applicable electrical codes and be properly grounded (earthed).

Locate the electrical supply as shown in the illustration on the following pages. A separate circuit servicing only this appliance is required. A ground fault circuit interrupter (GFCI) is not recommended and may cause interruption of operation.

ELECTRICAL REQUIREMENTS

Electrical Supply	220-240 V AC, 50/60 Hz
Service	0.2 A
Receptacle	grounding-type (earthed)
Power Cord	1.8 m

GAS SUPPLY

Installation must conform with all applicable gas codes.

A gas supply line of 19 mm rigid pipe must be provided to the cooktop. If local codes permit, a certified, .9 m long, 13 mm or 19 mm ID flexible metal appliance connector is recommended to connect the units ½" NPT (or ISO 7/1-14) male inlet to the gas supply line.

Gas Cooktops contain a regulator for natural gas and LP gas.

Wolf natural gas cooktops will function up to 3124 m in altitude without adjustment and LP gas cooktops will function up to 2621 m. If the installation exceeds these elevations, contact an authorized Wolf dealer for a high altitude conversion kit.

GAS REQUIREMENTS

NATURAL GAS	
Supply Pressure	WC 12.5 mbar
LP GAS	
Supply Pressure	WC 25 mbar

76 cm / 91 cm Cooktop

STANDARD INSTALLATION

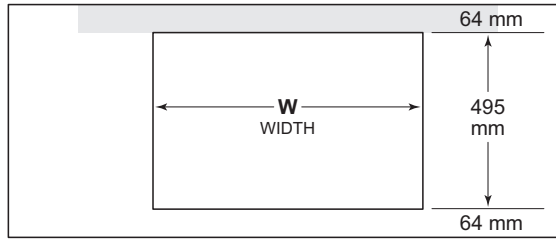

COUNTERTOP CUTOUT

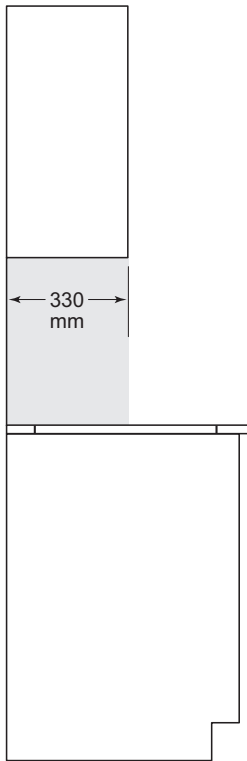

SIDE VIEW

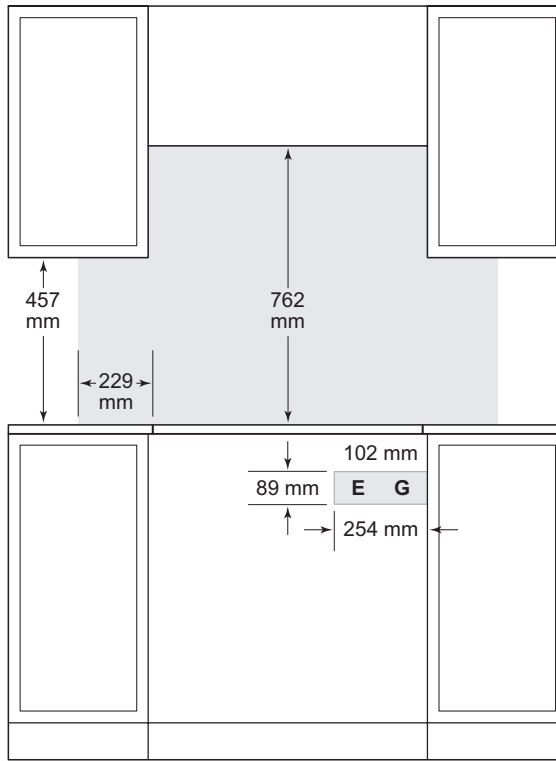

FRONT VIEW

*NOTE: Shaded area above countertop indicates minimum clearance to combustible surfaces, combustible materials cannot be located within this area.
Electrical and gas supply location only applies to installations with built-in oven.*

CUTOUT WIDTH	W
76 cm Cooktop	737 mm
91 cm Cooktop	889 mm

Module Cooktops

Wolf 38 cm Modules have been redesigned to match the updated lines of Sub-Zero and Wolf. Controls, grates, and trim allow them to integrate perfectly with their larger counterparts and deliver equal performance. Combine Modules à la carte-style to create a custom cooktop, or add specialty functions alongside an existing cooktop.

Full-size cooktops including ICBCI243TF/S, ICBCI304TF/S, and ICBCI365TF/S feature the same brushed stainless frame, making them ideal for pairing with Modules.

MODULE COOKTOPS



ICBCI152TF/S
INDUCTION



ICBSM15TF/S
STEAMER



ICBGM15TF/S
GRILL



ICBCG152TF/S
GAS



ICBMM15TF/S
MULTIFUNCTION

Module Cooktops

INDUCTION

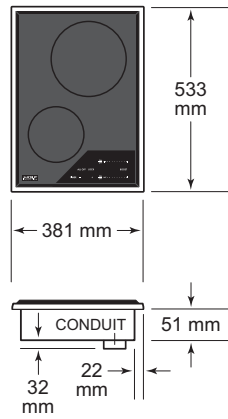

STEAMER

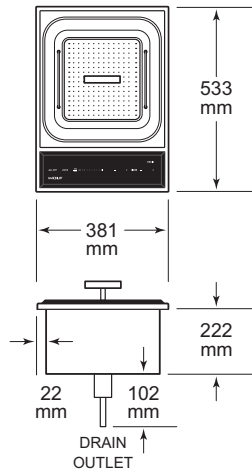

GRILL

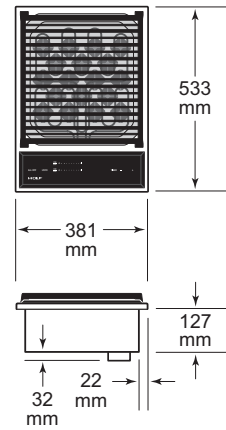

GAS

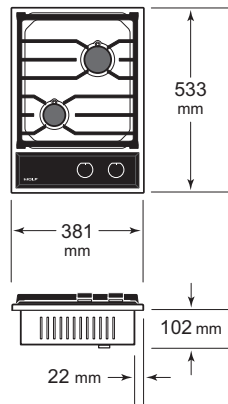

MULTIFUNCTION

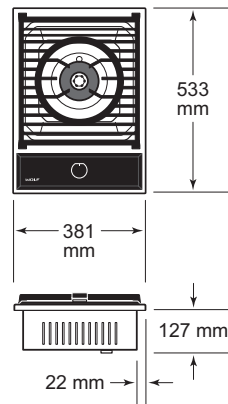

Planning Information

IMPORTANT NOTE: Wolf does not recommend the use of downdraft ventilation with the Steamer or Grill Modules.

A minimum 51 mm is required from the bottom of the Module to combustible materials.

Refer to the illustrations on the following pages for installation of Modules.

MULTIPLE COOKTOPS

When multiple Modules are installed side by side, refer to the chart and illustration below for typical configurations. The cutout dimensions provided will accommodate the use of an optional filler strip if desired.

COUNTERTOP CUTOUT	W
(2) 38 cm Modules*	737 mm
(3) 38 cm Modules*	1118 mm
(4) 38 cm Modules*	1505 mm
(5) 38 cm Modules*	1886 mm
(6) 38 cm Modules*	2267 mm
60 cm Cooktop / 38 cm Module*	956 mm
76 cm Cooktop / 38 cm Module*	1118 mm
76 cm Cooktop / (2) 38 cm Module*	1473 mm
91 cm Cooktop / 38 cm Module*	1270 mm

**Dimensions apply to ICBCI152TF/S, ICBCG152TF/S, ICBSM15TF/S, ICBGM15TF/S, and ICBMM15TF/S.*

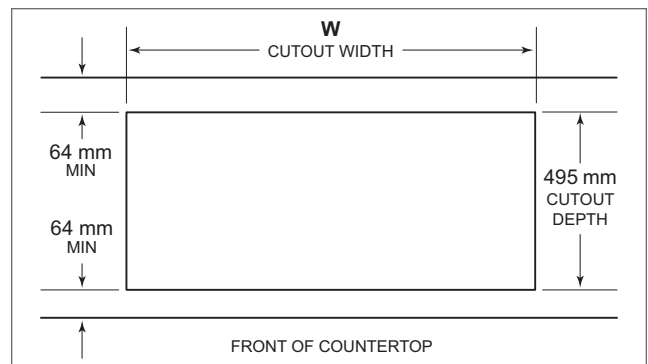

Countertop cutout

Planning Information

ELECTRICAL REQUIREMENTS

Installation must comply with all applicable electrical codes and be properly grounded (earthed).

Locate the electrical supply as shown in the illustrations on the following pages. A separate circuit servicing only this appliance is required.

The induction cooktop is supplied with a single phase and 3-phase convertible power inlet box.

When multiple cooktops or Modules are installed side by side, each must have its own separate electrical supply.

ELECTRICAL REQUIREMENTS

INDUCTION MODULE

Single Phase	220-240 VAC, 50/60 Hz
3-Phase	380-415 V AC, 50 Hz
Total Amps	16

ELECTRIC MODULES

Electrical Supply	220-240 VAC, 50/60 Hz
Steamer	2700 W
Grill	2800 W

GAS MODULES

Electrical Supply	220-240 VAC; 50/60 Hz
Service	0.2 A
Receptacle	grounding-type (earthed)
Power Cord	1.8 m

DRAIN OUTLET

The Steamer Module requires a method for draining hot water. Options include connecting a drain hose from the 16 mm outlet tied into an existing drain, a separate drain with freefall, or placing a heat-resistant receptacle under the drain outlet.

GAS SUPPLY

Installation must conform with all applicable gas codes.

For gas Modules, a gas supply line of 19 mm rigid pipe must be provided to the module. If local codes permit, a certified, .9 m long, 13 mm or 19 mm ID flexible metal appliance connector is recommended to connect the units ½" NPT (or ISO 7/1-14) male inlet to the gas supply line.

When multiple Gas Cooktops or Modules are installed side by side, they can receive their gas supply from a common line. However, each unit must have its own regulator installed between the mainline and the cooktop or Module.

Wolf natural gas cooktops will function up to 3124 m in altitude without adjustment and LP gas cooktops will function up to 2621 m. If the installation exceeds these elevations, contact an authorized Wolf dealer for a high altitude conversion kit.

GAS REQUIREMENTS

NATURAL GAS	WC
Supply Pressure	25 mbar

LP GAS	WC
Supply Pressure	37 mbar

Induction Module

STANDARD INSTALLATION

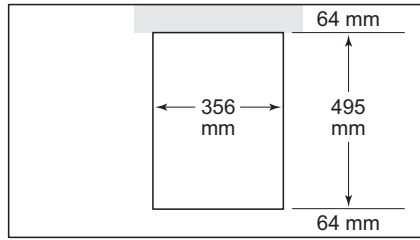

COUNTERTOP CUTOUT

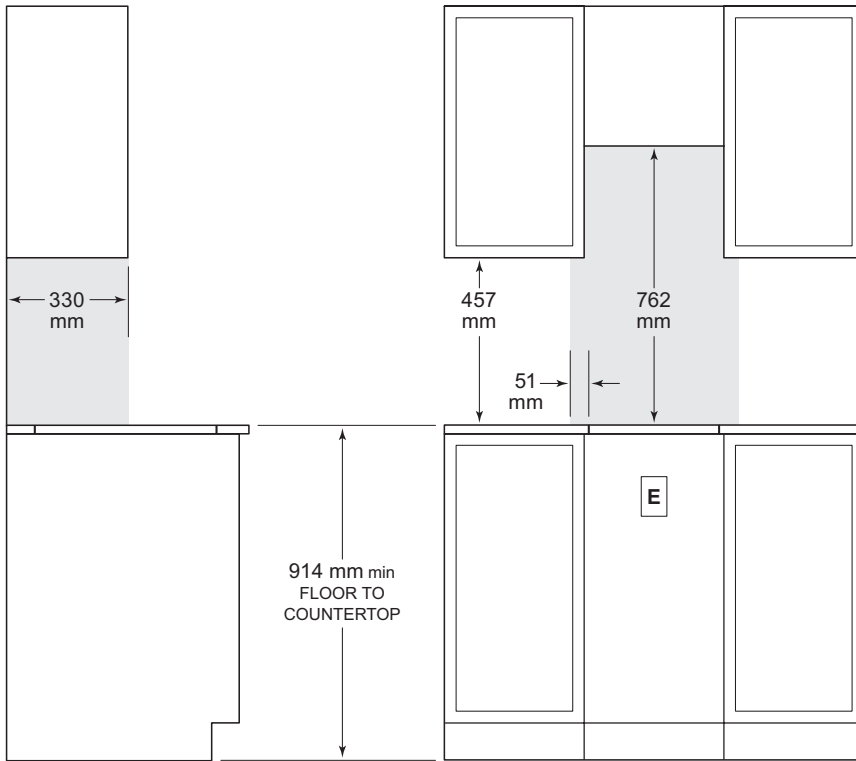

SIDE VIEW

FRONT VIEW

NOTE: Shaded area above countertop indicates minimum clearance to combustible surfaces, combustible materials cannot be located within this area.

Steamer Module

STANDARD INSTALLATION

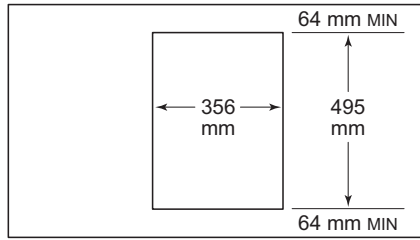

COUNTERTOP CUTOUT

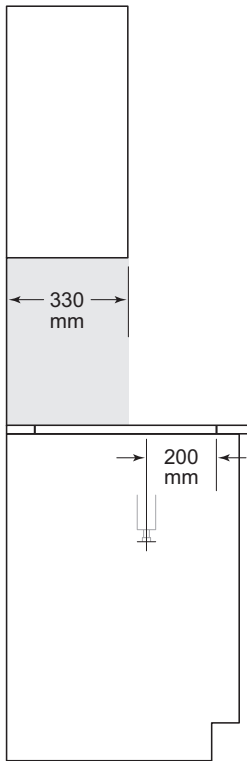

SIDE VIEW

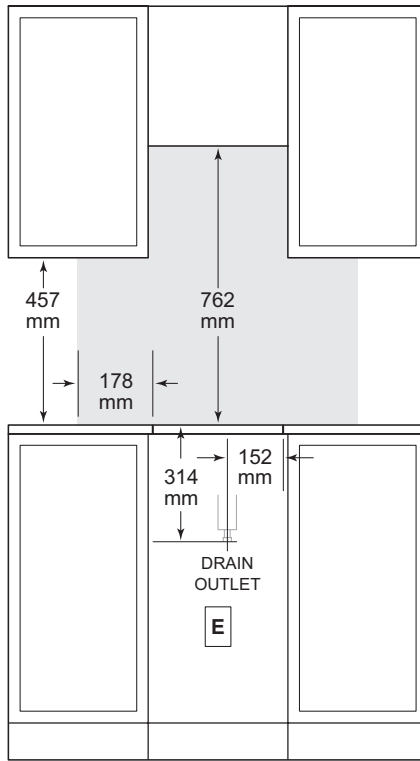

FRONT VIEW

NOTE: Shaded area above countertop indicates minimum clearance to combustible surfaces, combustible materials cannot be located within this area.

Grill Module

STANDARD INSTALLATION

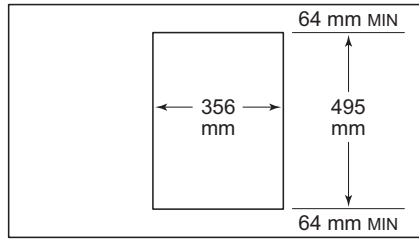

COUNTERTOP CUTOUT

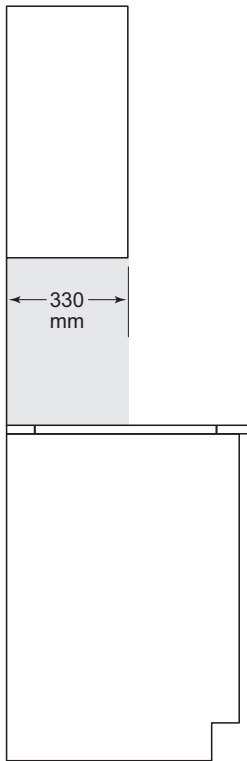

SIDE VIEW

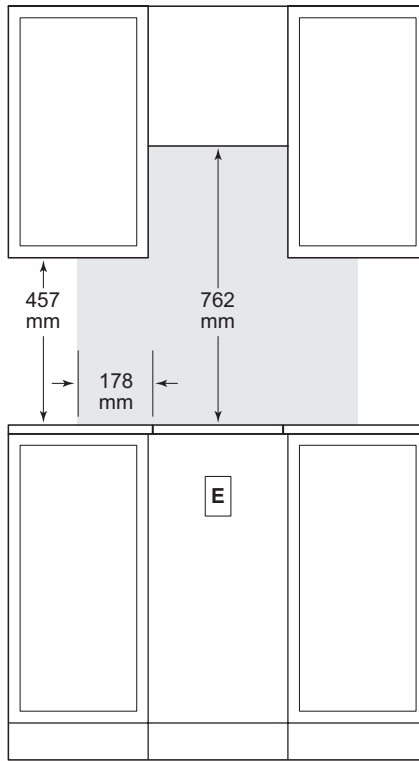

FRONT VIEW

NOTE: Shaded area above countertop indicates minimum clearance to combustible surfaces, combustible materials cannot be located within this area.

Gas / Multifunction Module

STANDARD INSTALLATION

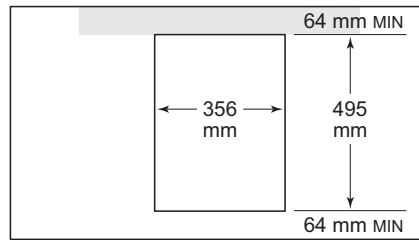

COUNTERTOP CUTOUT

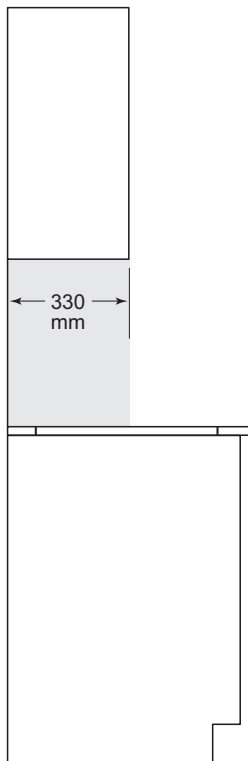

SIDE VIEW

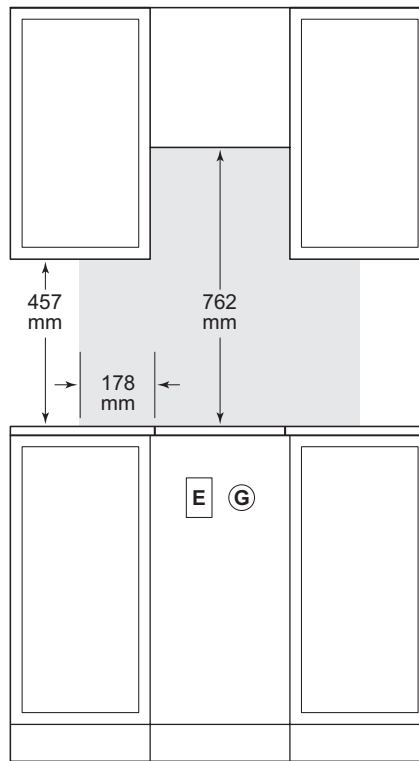

FRONT VIEW

NOTE: Shaded area above countertop indicates minimum clearance to combustible surfaces, combustible materials cannot be located within this area.

Coffee Systems

Make professional-quality coffee, espresso, cappuccino, latte, and more. The Wolf Coffee System automatically steams and foams the milk perfectly. The water temperature and brew strength are adjustable. It uses either whole-bean or ground coffee. The design pairs beautifully, either side-by-side or in a tower application, with other Wolf products such as the Convection Steam Oven. The Coffee System can be installed in a standard or flush inset application.

COFFEE SYSTEMS

60 cm TRANSITIONAL



ICBEC2450TE/S

76 cm TRANSITIONAL

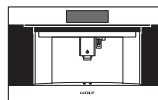

ICBEC3050TE/S

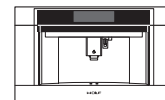

ICBEC3050TM/S

76 cm PROFESSIONAL

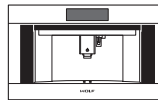

ICBEC3050PE/S

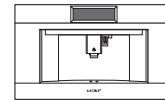

ICBEC3050PM/S

76 cm CONTEMPORARY

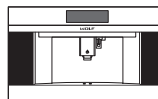

ICBEC3050CM/S

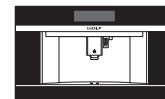

ICBEC3050CM/B

Coffee System

DIMENSIONS

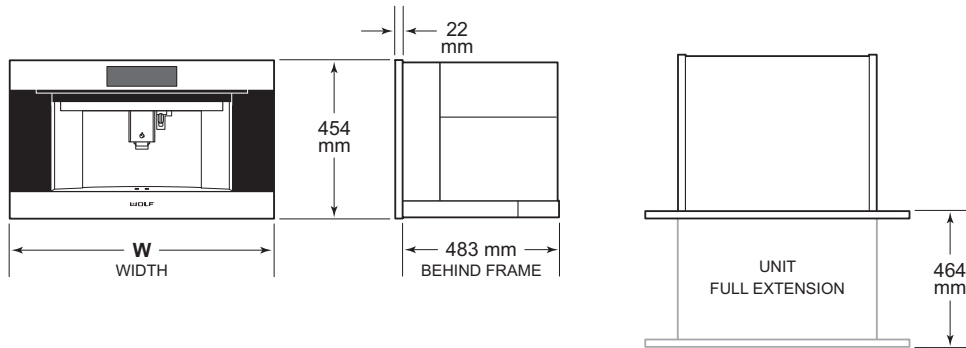

WIDTH

W

60 cm Model	597 mm
76 cm Trim	759 mm

Planning Information

The Coffee System can be installed in a standard or flush inset application. The sides of the cabinet opening must be adequate to support installation of the mounting slides. Refer to the illustration below.

Finish the edges of the opening.

For standard installations, the face trim overlaps stiles and rails. Refer to the chart below.

For flush inset installations, a minimum 3 mm reveal is required on all sides. Each corner of the opening must be exactly 90° to maintain consistent reveals.

INSTALLATION REQUIREMENTS

Coffee System 45 kg

TRIM OVERLAP	60 cm MODEL	76 cm MODEL
Top	5 mm	5 mm
Bottom	0 mm	0 mm
Sides	18 mm	98 mm

ELECTRICAL REQUIREMENTS

Installation must comply with all applicable electrical codes and be properly grounded (earthed).

Locate the electrical supply as shown in the illustrations on the following pages. A separate circuit servicing only this appliance is required. A ground fault circuit interrupter (GFCI) is not recommended and may cause interruption of operation.

ELECTRICAL REQUIREMENTS

Electrical Supply	220-240 V AC, 50/60 Hz
Service	1350 W
Receptacle	grounding-type (earthed)
Power Cord	1.8 m

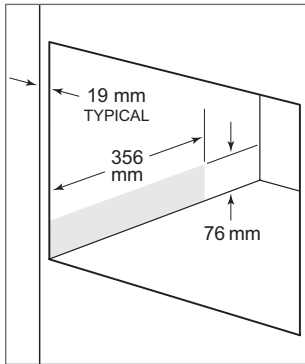

Side support

Coffee System

STANDARD INSTALLATION

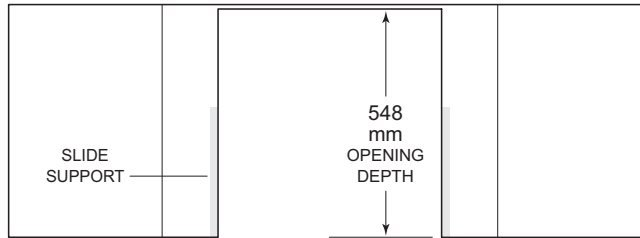

TOP VIEW

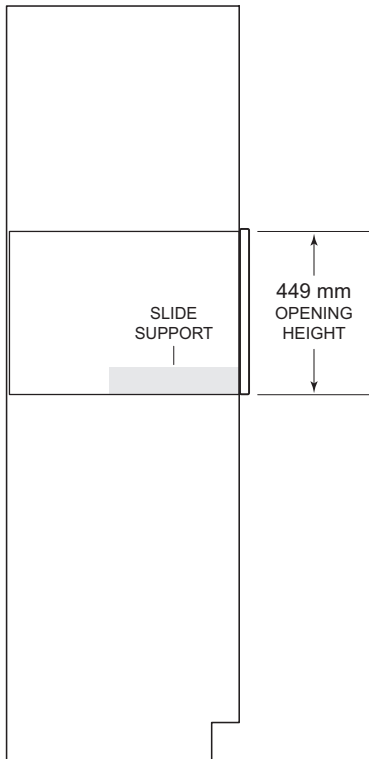

SIDE VIEW

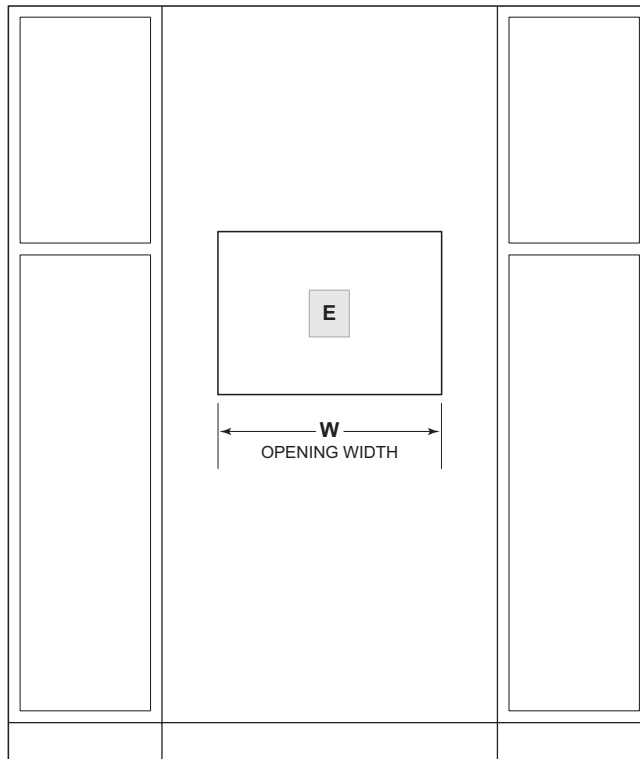

FRONT VIEW

NOTE: 610 mm model and model with 762 mm trim require the same opening dimensions.

OPENING WIDTH	W
60 cm Model	562 mm
76 cm Trim	562 mm

Coffee System

FLUSH INSET INSTALLATION

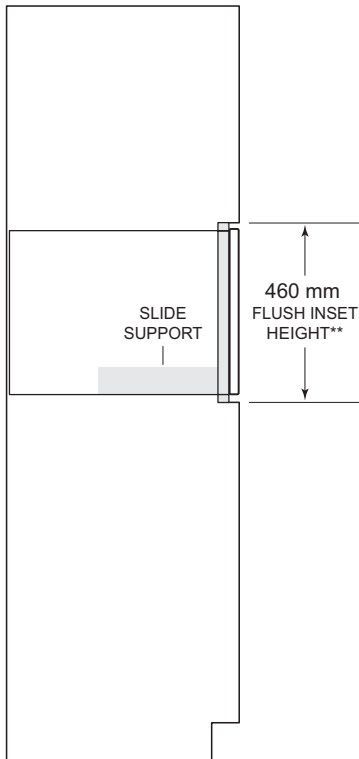
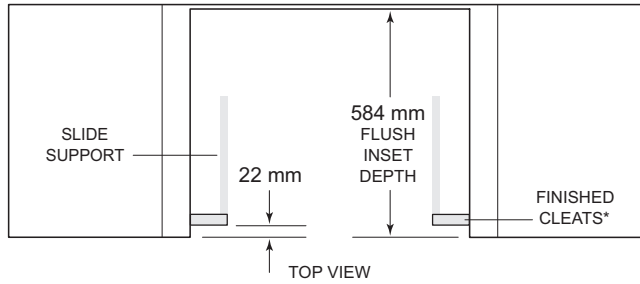

SIDE VIEW

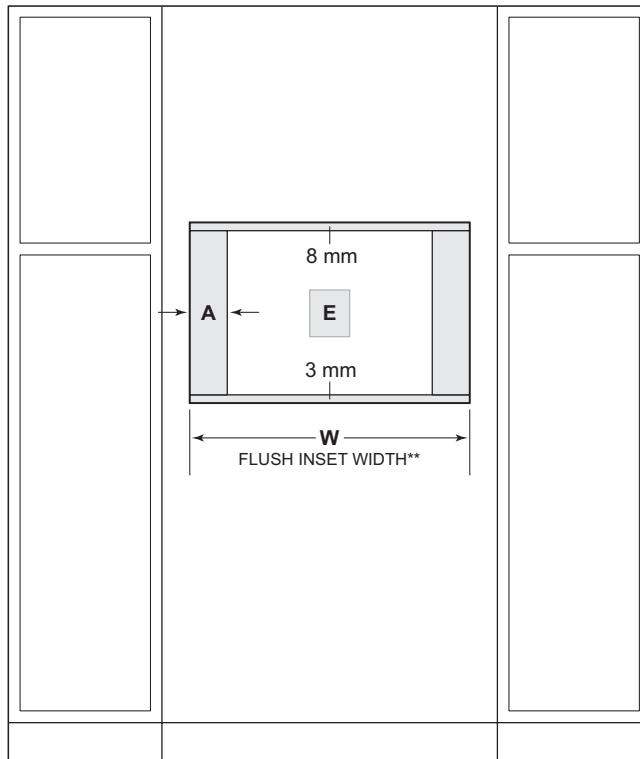

FRONT VIEW

*Will be visible and should be finished to match cabinetry.

**Dimension provides minimum reveals.

FLUSH INSET WIDTH	W	A
60 cm Model	603 mm	21 mm
76 cm Trim	765 mm	102 mm

Vacuum Seal Drawer

Vacuum Seal Drawer

The Vacuum Seal Drawer can be installed in a standard or flush inset application. Stainless steel, black glass, and integrated drawer fronts are available in 61 cm and 76 cm widths. The integrated drawer front allows for a custom panel.

DRAWER FRONTS



STAINLESS STEEL



BLACK GLASS



INTEGRATED

DIMENSIONS

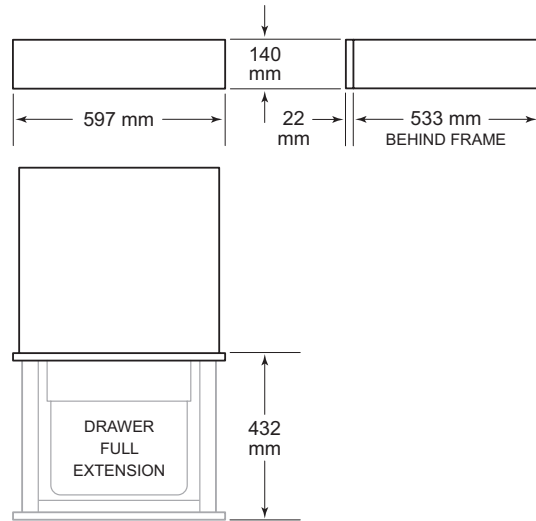

DRAWER FRONT DIMENSIONS



DRAWER FRONT	W
61 cm Drawer Front	597 mm
76 cm Drawer Front	759 mm

Planning Information

The Vacuum Seal Drawer can be installed in a standard or flush inset application. Finish the edges of the opening. They may be visible when the drawer is open.

For standard installations, the face trim will overlap stiles and rails. Refer to the chart below.

For flush inset installations, a minimum 3 mm reveal is required on all sides. To ensure consistent reveals, each corner of the opening must be exactly 90°.

INSTALLATION REQUIREMENTS

Minimum Base Support	34 kg
----------------------	-------

TRIM OVERLAP

Top	0 mm
Bottom	0 mm
Sides	18 mm

ELECTRICAL REQUIREMENTS

Installation must comply with all applicable electrical codes and be properly grounded (earthed).

Locate the electrical supply as shown in the illustrations on the following pages. A separate circuit servicing only this appliance is required. A ground fault circuit interrupter (GFCI) is not recommended and may cause interruption of operation.

ELECTRICAL REQUIREMENTS

Electrical Supply	220–240 V AC, 50/60 Hz
Service	320 W
Receptacle	grounding-type (earthed)
Power Cord	.9 m

Vacuum Seal Drawer

Vacuum Seal Drawer

STANDARD INSTALLATION

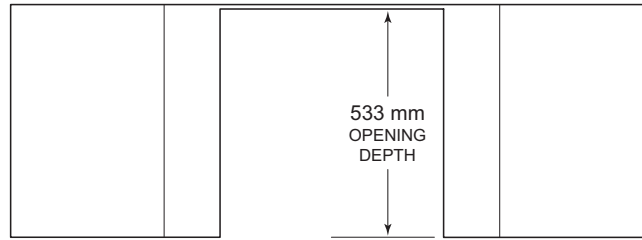

TOP VIEW

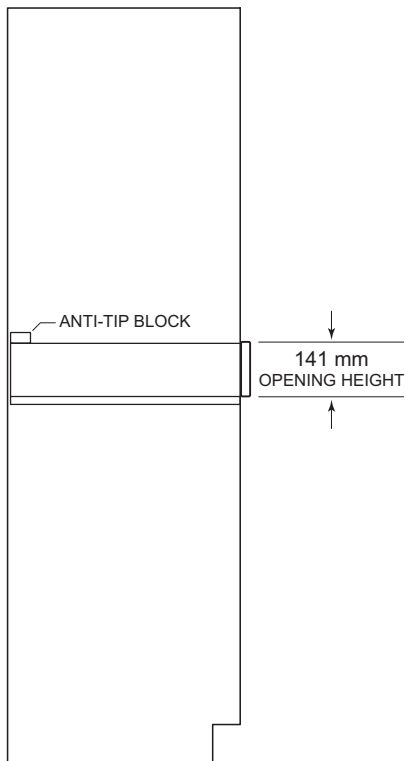

SIDE VIEW

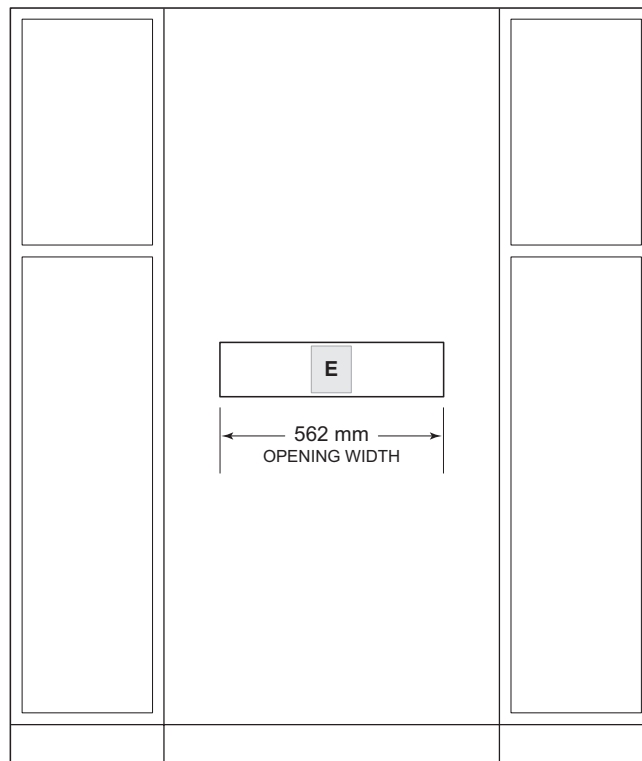

FRONT VIEW

Vacuum Seal Drawer

FLUSH INSET INSTALLATION

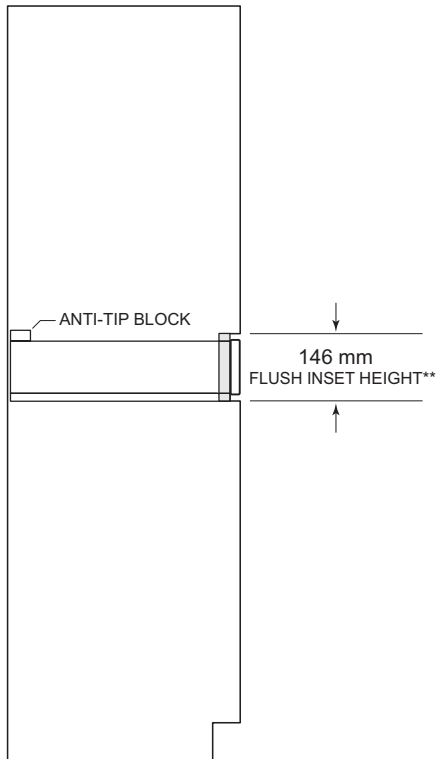
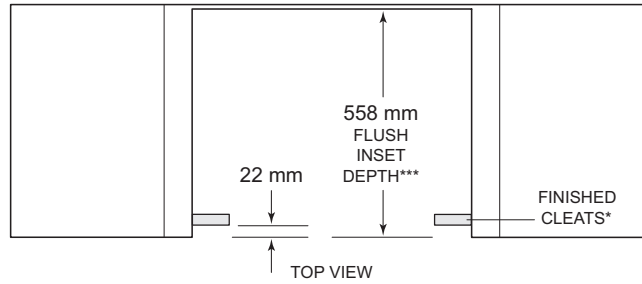

SIDE VIEW

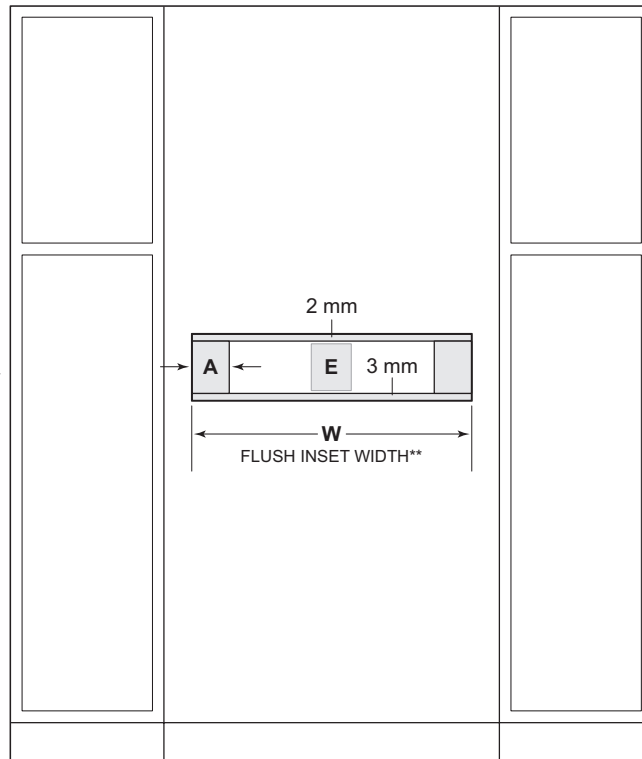

FRONT VIEW

*Will be visible and should be finished to match cabinetry.

**Dimension provides minimum reveals.

***Does not include additional depth for the electrical connection.

FLUSH INSET WIDTH	W	A
610 mm Opening	603 mm	21 mm
762 mm Opening	765 mm	102 mm

Dual Fuel Ranges

Discover a new world of cooking—the best of two worlds, actually—with a Wolf Dual Fuel Range. Topside, gas cooking in all its glory, with the fine control of dual-stacked, sealed burners and options including charbroiler and griddle. Below, that marvel of culinary technology, the Wolf convection electric oven. Its two fans and four heating elements let you select from ten cooking modes so you can choose the one precisely suited to the dish you're preparing. The ovens are self-cleaning. With a variety of range widths to choose from, kitchens large and small become gateways to the exciting new world of dual fuel cooking. All models are constructed of stainless steel and can be ordered in natural or LP gas.

CONFIGURATIONS

76 cm RANGE

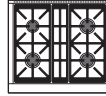

ICBDF30450/S/P

122 cm RANGE

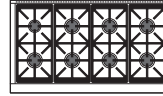

ICBDF48850/S/P

152 cm RANGE

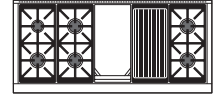

ICBDF60650CG/S/P

91 cm RANGE

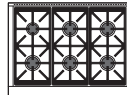

ICBDF36650/S/P

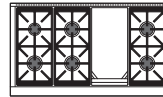

ICBDF48650G/S/P

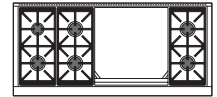

ICBDF60650DG/S/P

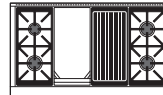

ICBDF48450CG/S/P

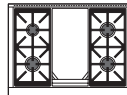

ICBDF36450G/S/P

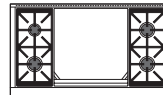

ICBDF48450DG/S/P

Overall Dimensions

76 cm RANGE

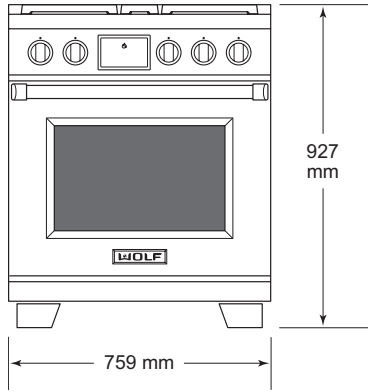

91 cm RANGE

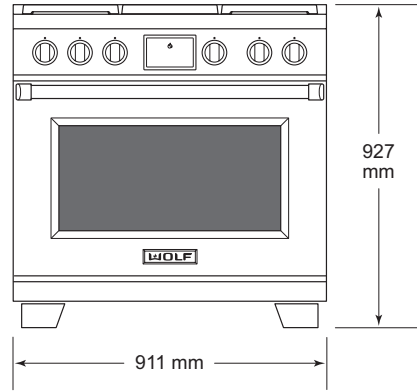

122 cm RANGE

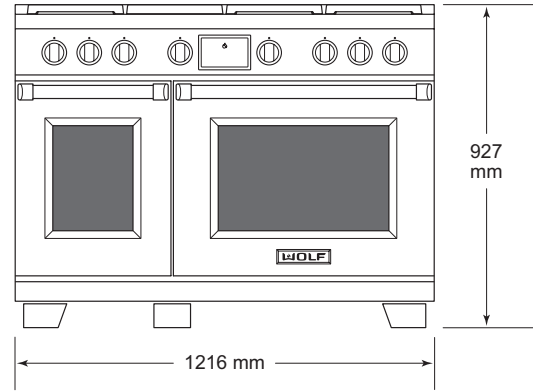

152 cm RANGE

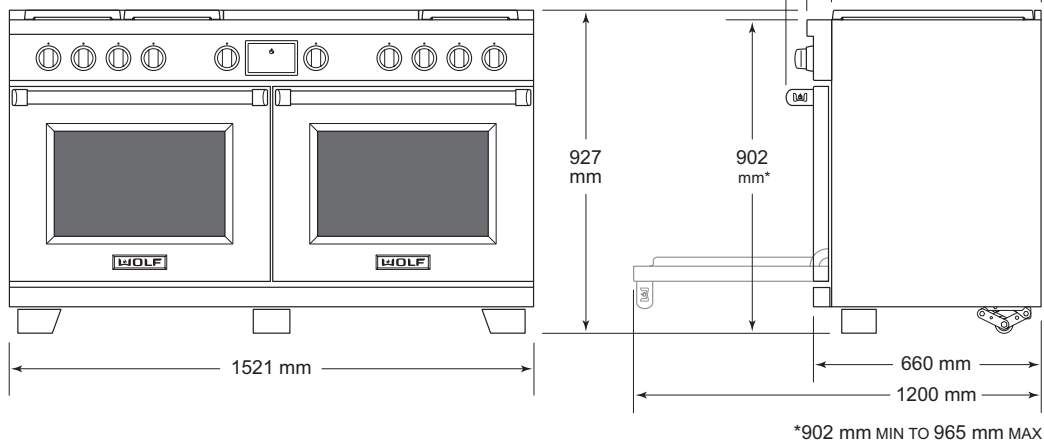

SIDE VIEW—ALL RANGES

Planning Information

When installing against a combustibile surface, a minimum 254 mm riser is required for a 91 cm Wolf Dual Fuel Range with charbroiler or griddle and all 122 cm and 152 cm models. Follow all minimum clearances to combustibile surfaces shown in the illustration on the following page.

A Wolf Pro Ventilation Hood is recommended with the Wolf Dual Fuel Range. Refer to Pro Ventilation on page 104.

ELECTRICAL REQUIREMENTS

Installation must comply with all applicable electrical codes and be properly grounded (earthed).

Locate the electrical supply flush with the wall or floor and within the shaded area shown in the illustration on the following page. A separate circuit servicing only this appliance is required.

If a power supply cord is used, the cord must be designated for use with ranges and rated for 240 V, 30 or 50 amps (refer to the chart below), and must include 3 or 4 conductors.

Performance may be compromised if the electrical supply is less than 240 volts.

ELECTRICAL REQUIREMENTS

ELECTRICAL SUPPLY

Single Phase	220–240 V AC, 50/60 Hz
3-Phase	380–415 V AC, 50 Hz

MAX CONNECTED LOAD	SINGLE PHASE	3-PHASE
76 cm Range	20.5 A	19.2 A
91 cm Range	20.5 A	19.2 A
122 cm Range	38.9 A	19.2 A
152 cm Range	40.8 A	19.2 A

Planning Information

GAS REQUIREMENTS

Installation must conform with all applicable gas codes.

Locate the gas supply within the shaded area shown in the illustration on the following page.

A gas supply line of 19 mm rigid pipe must be provided to the range. If local codes permit, a certified, .9 m long, 13 mm or 19 mm ID flexible metal appliance connector is recommended to connect the units ISO 7/1-14 female inlet to the gas supply line.

Wolf natural gas ranges will function up to 3124 m in altitude without adjustment and LP gas ranges will function up to 2621 m. If the installation exceeds these elevations, contact an authorized Wolf dealer for a high altitude conversion kit.

GAS SUPPLY PRESSURE	WC
Natural Gas	25 mbar
LP Gas	37 mbar

Dual Fuel Ranges

Dual Fuel Range

INSTALLATION

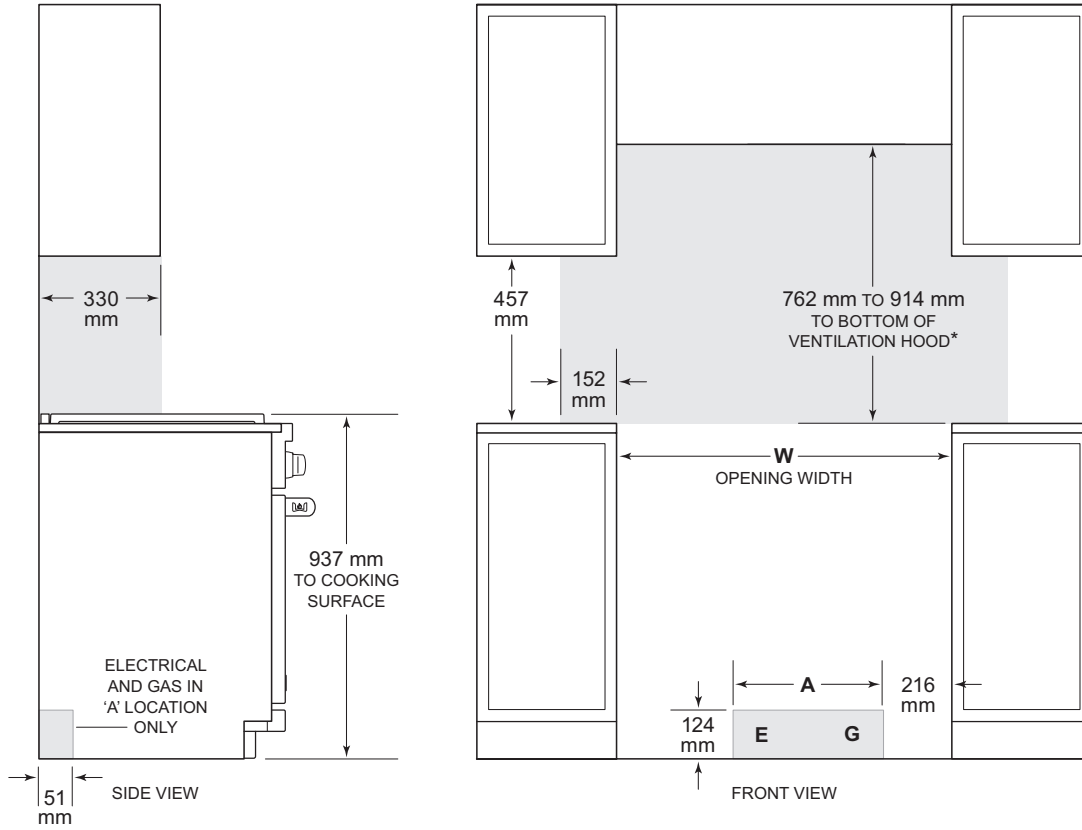

*Without ventilation hood, 914 mm minimum clearance countertop to combustible materials, 1118 mm for charbroiler.

NOTE: Shaded area above countertop indicates minimum clearance to combustible surfaces. Combustible materials cannot be located within this area.

For island installation, 305 mm minimum clearance back of range to combustible rear wall above countertop.

OPENING WIDTH	W	A
76 cm Range	762 mm	260 mm
91 cm Range	914 mm	413 mm
122 cm Range	1219 mm	464 mm
152 cm Range	1524 mm	464 mm

Induction Ranges

Experience a new way of cooking with a Wolf Induction Range. Magnetism allows the ultrafast, energy efficient surface elements to heat up instantly and with perfectly distributed heat. Heat generation stops the instant you turn off the element or remove the pan. The cooktop's surface remains cool. Your kitchen stays cooler too. The electric convection oven with two fans and four heating elements let you select from ten cooking modes and is self-cleaning. Wolf Induction Ranges are constructed of stainless steel and come in 76 cm and 91 cm widths.

CONFIGURATIONS

76 cm RANGE



ICBIR30450/S/T

91 cm RANGE

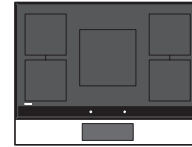

ICBIR36550/S/T

Overall Dimensions

76 cm RANGE

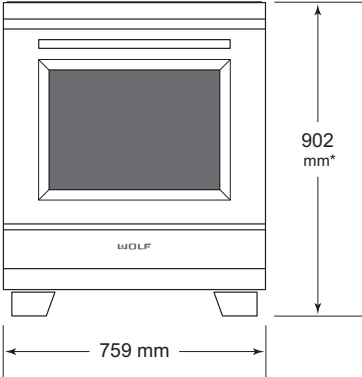

91 cm RANGE

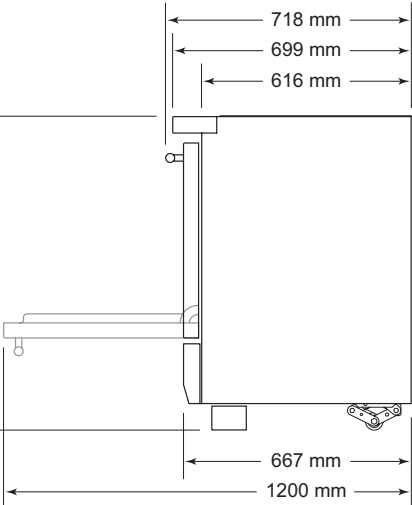
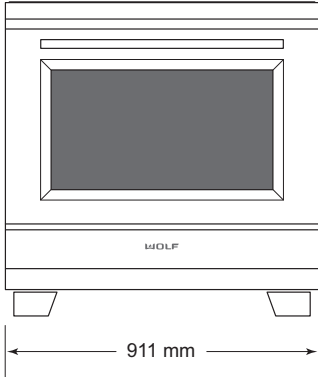

*902 mm MIN TO 965 mm MAX

76 cm / 91 cm RANGE SIDE VIEW

Planning Information

Follow all minimum clearances to combustibles shown in the illustration on the following page.

ELECTRICAL REQUIREMENTS

Installation must comply with all applicable electrical codes and be properly grounded (earthed).

Locate the electrical supply flush with the wall or floor and within the shaded area shown in the illustration on the following page. A separate circuit servicing only this appliance is required.

If a power supply cord is used, the cord must be designed for use with ranges and rated for 240 V, 50 amps, and must include 3 or 4 conductors.

Performance may be compromised if the electrical supply is less than 240 volts.

ELECTRICAL REQUIREMENTS

ELECTRICAL SUPPLY

Single Phase	220–240 V AC, 50/60 Hz
3-Phase	380–415 V AC, 50 Hz

MAX CONNECTED LOAD	SINGLE PHASE	3-PHASE
76 cm Range	50 A	19 A
91 cm Range	60 A	33 A

Induction Range

Induction Range

INSTALLATION

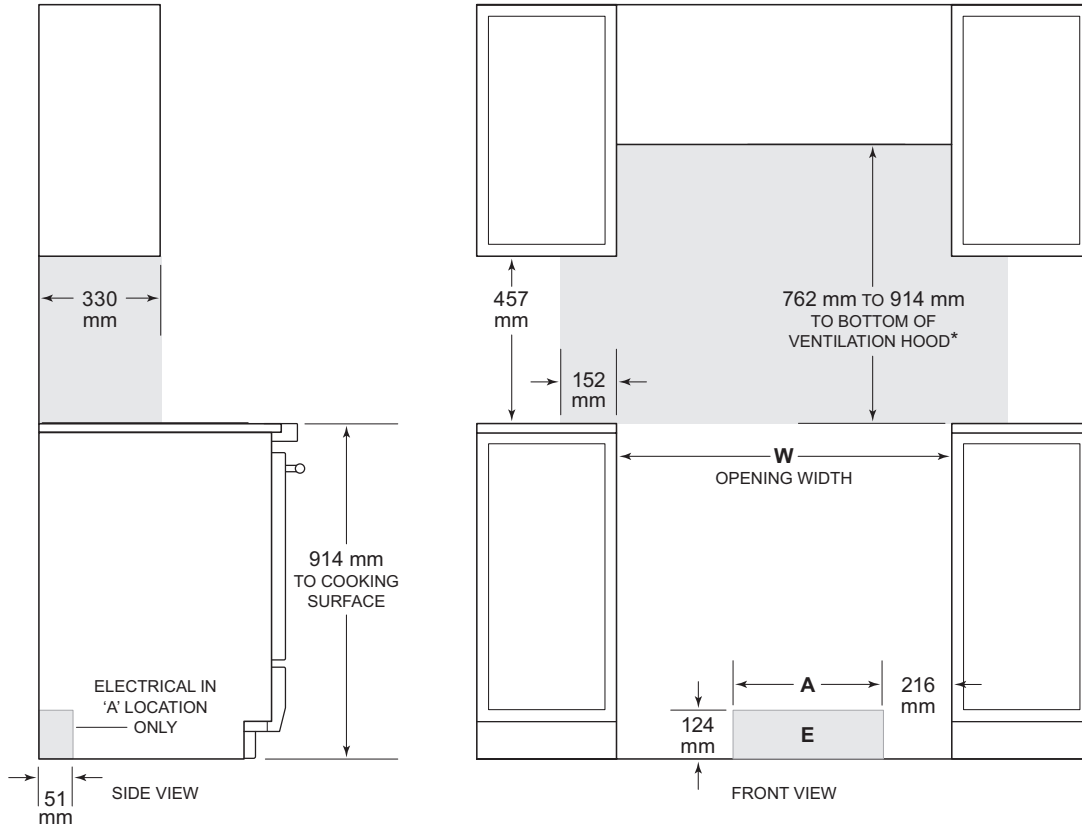

*Without ventilation hood, 914 mm minimum clearance countertop to combustible materials.

NOTE: Shaded area above countertop indicates minimum clearance to combustible surfaces. Combustible materials cannot be located within this area.

For island installation, 305 mm minimum clearance back of range to combustible rear wall above countertop.

OPENING WIDTH	W	A
76 cm Range	762 mm	260 mm
91 cm Range	914 mm	413 mm

Sealed Burner Rangetops

Wolf Sealed Burner Rangetops incorporate all the gas cooking features of a Wolf Dual Fuel Range. Customize your rangetop with your preferred combination of burners, infrared griddle, charbroiler, or wok burner. All Sealed Burner Rangetop models are constructed of stainless steel and can be ordered in natural or LP gas.

CONFIGURATIONS

91 cm RANGETOP

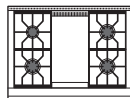

ICBSRT364G

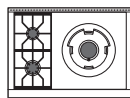

ICBSRT362W

122 cm RANGETOP

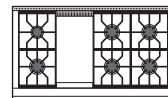

ICBSRT486G

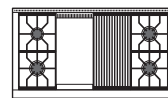

ICBSRT484CG

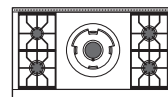

ICBSRT484W

Sealed Burner Rangetops

Sealed Burner Rangetops

91 cm RANGETOP

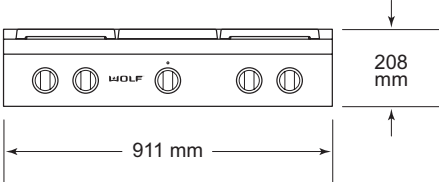

122 cm RANGETOP

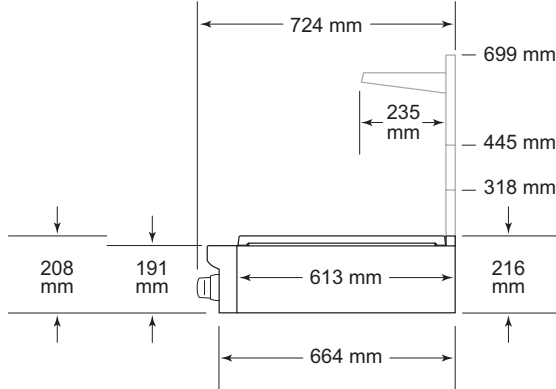
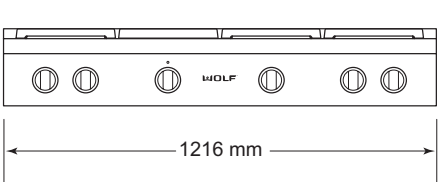

SIDE VIEW—ALL RANGETOPS

Planning Information

The platform to support the Sealed Burner Rangetop must include a cutout for electrical and gas supply connections. Refer to the chart below for minimum base support.

When installing against a combustible surface, a minimum 254 mm riser is required for 91 cm and 122 cm Sealed Burner Rangetops with a charbroiler or griddle. Follow all minimum clearances to combustible surfaces shown in the illustration on the following page. Models ICBSRT362W and ICBSRT484W cannot be installed against a combustible surface.

A Wolf Pro Ventilation Hood is recommended with the Sealed Burner Rangetop. Refer to page 102 for Pro Ventilation.

INSTALLATION REQUIREMENTS

PLATFORM

Thickness	19 mm
-----------	-------

BASE SUPPORT

	MIN
91 cm Rangetop	113 kg
122 cm Rangetop	136 kg

ELECTRICAL REQUIREMENTS

Installation must comply with all applicable electrical codes and be properly grounded (earthed).

Locate the electrical supply within the shaded area shown in the illustration on the following page. A separate circuit servicing only this appliance is required.

ELECTRICAL REQUIREMENTS

Electrical Supply	grounded, 220-240 VAC; 50/60 Hz
Service	0.2 A
Receptacle	grounding-type (earthed)
Power Cord	2 m

GAS SUPPLY

Installation must conform with all applicable gas codes.

A gas supply line of 19 mm rigid pipe must be provided to the rangetop. If local codes permit, a certified, .9 m long, 13 mm or 19 mm ID flexible metal appliance connector is recommended to connect the units ISO 7/1-14 female inlet to the gas supply line.

Wolf natural gas rangetops will function up to 3124 m in altitude without adjustment and LP gas ranges will function up to 2621 m. If the installation exceeds these elevations, contact an authorized Wolf dealer for a high altitude conversion kit.

GAS REQUIREMENTS

NATURAL GAS	WC
Supply Pressure	25 mbar
LP GAS	WC
Supply Pressure	37 mbar

Sealed Burner Rangetops

Sealed Burner Rangetop

INSTALLATION

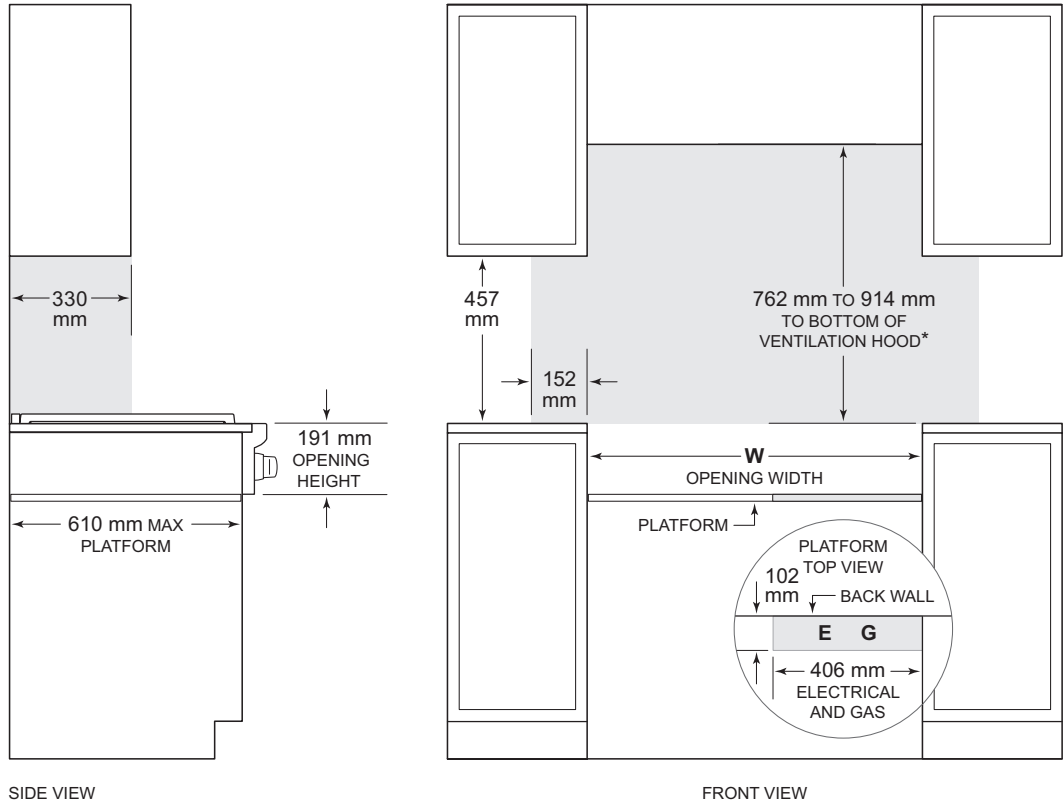

SIDE VIEW

FRONT VIEW

*Without ventilation hood, 914 mm minimum clearance countertop to combustible materials, 1118 mm for charbroiler.

NOTE: Shaded area above countertop indicates minimum clearance to combustible surfaces, combustible materials cannot be located within this area.

Electrical and gas supply located through bottom of platform.

For island installation, 305 mm minimum clearance back of range to combustible rear wall above countertop.

OPENING WIDTH	W
91 cm Model	914 mm
122 cm Model	1219 mm

Outdoor Grills and Modules

Taste what happens when the heritage of professional cooking moves from the kitchen to the patio. Like their indoor counterparts, Wolf Outdoor Grills are precision instruments. Constructed of heavy-duty stainless steel, the 76 cm, 91 cm, 107 cm, and 137 cm Grills have powerful burners every five inches for even heat distribution. An electric rotisserie with infrared burner produces succulent poultry and roasts. All Grill models can be built in and all except the 137 cm Grill, can be used on a cart for portable convenience. The 25,000 Btu Burner Module can be built into an outdoor kitchen and the Side Burner attached to a cart. Wolf Grills and Modules can be ordered in natural or LP gas.

OUTDOOR GRILLS

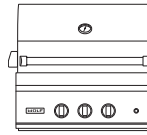

ICBOG30

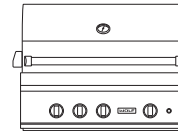

ICBOG36

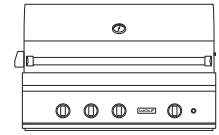

ICBOG42

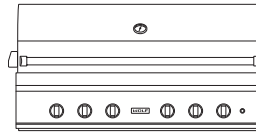

ICBOG54

OUTDOOR MODULES



ICBBM13
BURNER MODULE



ICBSB13
SIDE BURNER

Outdoor Grills and Modules

OUTDOOR GRILL

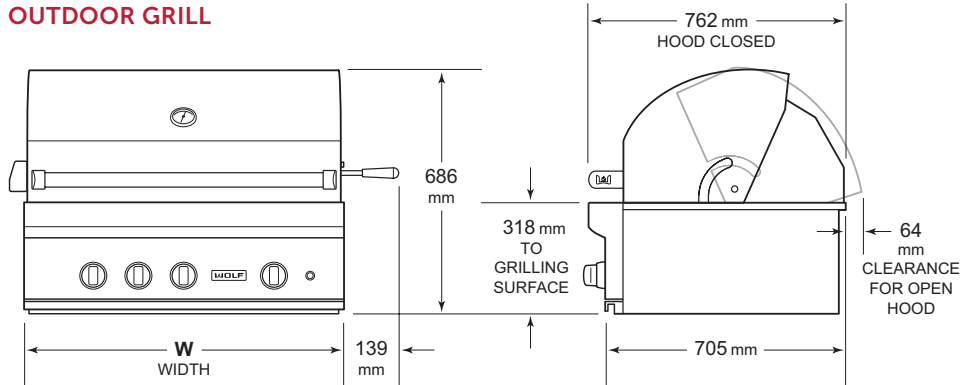

GRILL CART

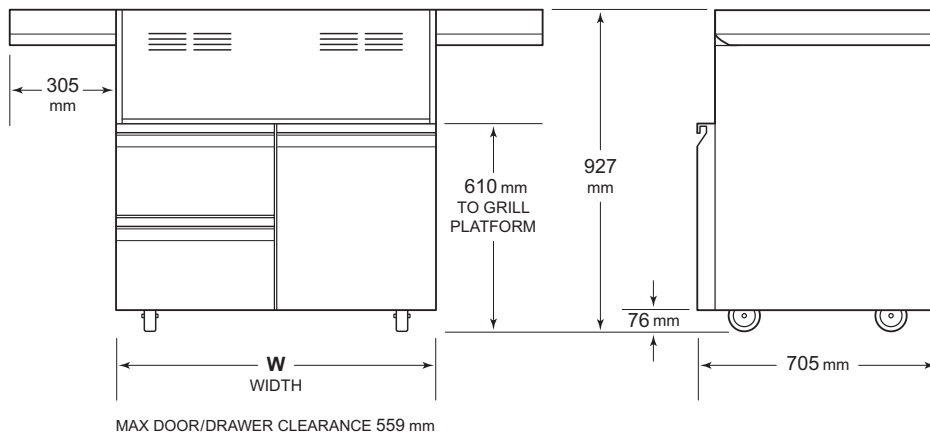

BURNER MODULE / SIDE BURNER

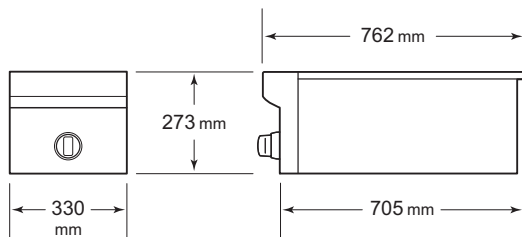

OUTDOOR GRILL

W

ICBOG30	762 mm
ICBOG36	914 mm
ICBOG42	1067 mm
ICBOG54	1372 mm

GRILL CART

W

ICBCART30	762 mm
ICBCART36	914 mm
ICBCART42	1067 mm

Planning Information

For portable applications, Wolf Grill carts are designed specifically to fit Grill models ICBOG30, ICBOG36, and ICBOG42 and the Side Burner. Model ICBOG54 is designed for built-in applications only.

For built-in applications, Wolf Outdoor Grills and the Burner Module are designed for easy placement into a built-in enclosure. For Outdoor Grills, installation in a combustible enclosure requires an insulating liner. For the Burner Module, an insulating liner is not required. The enclosure should be built according to specifications for your specific installation on the following pages. If the Burner Module is installed next to an Outdoor Grill, a minimum of 305 mm is required between the units. A rotisserie side conversion kit is available from an authorized Wolf dealer.

Optional stainless steel accessory doors and drawers are available for built-in applications. Refer to pages 86–90.

Grill carts, insulating liners, and stainless steel doors and drawers are available through an authorized Wolf dealer.

ELECTRICAL REQUIREMENTS

Installation must comply with all applicable electrical codes and be properly grounded (earthed).

The electrical outlet must be located within reach of the power cord. A separate circuit servicing only this appliance is required.

IMPORTANT NOTE: A ground fault circuit interrupter (GFCI) or residual current device (RCD) is required to reduce the risk of electrical shock.

ELECTRICAL REQUIREMENTS (GRILL / MODULE)

Electrical Supply	grounded, 220-240 VAC, 50/60 Hz
Service	1 A
Receptacle	3-prong grounding-type (earthed), IEC inlet

ELECTRICAL REQUIREMENTS (ROTISSERIE)

Electrical Supply—Input	grounded, 220-240 VAC, 50/60 Hz
Electrical Supply—Output	12 VDC
Service	0.5 A (6 Watts)
Receptacle	barrel plug, 2.1 mm ID x 5.5 mm OD

Planning Information

GAS SUPPLY

Installation must conform with all applicable gas codes.

A gas supply line of 19 mm rigid pipe must be provided to the outdoor grill or module. If local codes permit, a certified, .9 m long, 13 mm or 19 mm ID flexible metal appliance connector is recommended to connect the units ISO 7-1 female inlet to the gas supply line.

An inline regulator is installed on the unit for connecting to NAT or LP gas sources. For local dealer information, visit our website, wolfappliance.com.

If the Outdoor Grill is being connected to a whole house LP supply, the LP gas pressure regulator is not provided. It can be purchased from an authorized Wolf dealer.

GAS REQUIREMENTS

NATURAL GAS

Supply Pressure	12.5 mbar
Min Line Pressure	17.5 mbar
Max Regulator Pressure	100 mbar

LP GAS

Supply Pressure	25 mbar
Min Line Pressure	27.4 mbar
Max Regulator Pressure	100 mbar

Outdoor Grill

NON-COMBUSTIBLE INSTALLATION

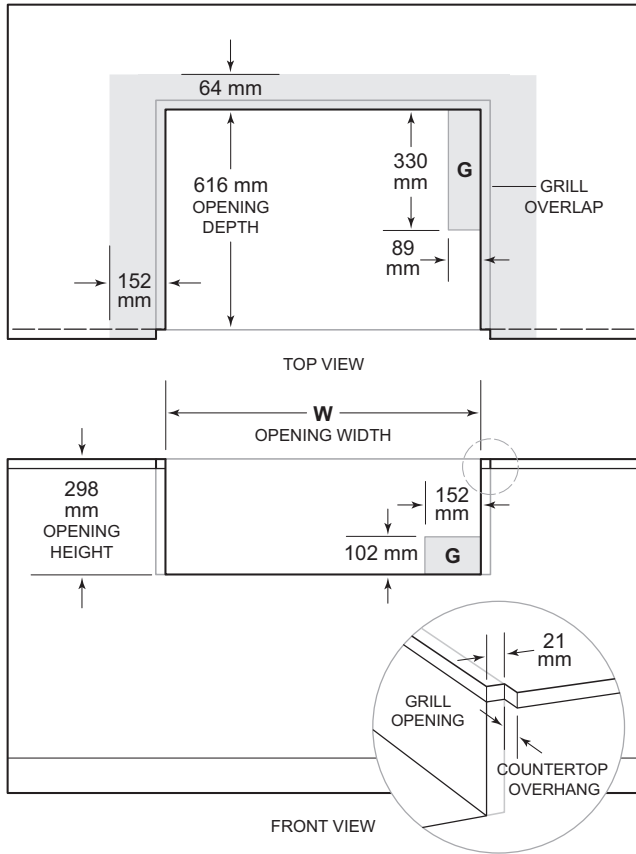

NOTE: Shaded area above countertop indicates minimum clearance to combustible surfaces, combustible materials cannot be located within this area.

COMBUSTIBLE INSTALLATION

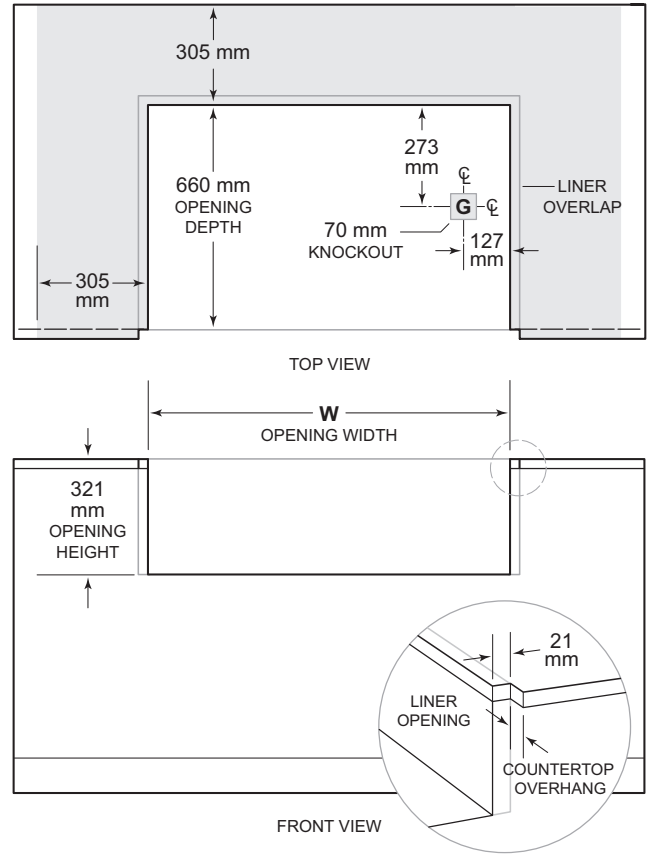

NOTE: Shaded area above countertop indicates minimum clearance to combustible surfaces, combustible materials cannot be located within this area.

NON-COMBUSTIBLE ENCLOSURE	W
ICBOG30	724 mm
ICBOG36	876 mm
ICBOG42	1029 mm
ICBOG54	1334 mm

COMBUSTIBLE ENCLOSURE	W
ICBOG30	851 mm
ICBOG36	1003 mm
ICBOG42	1156 mm
ICBOG54	1461 mm

For installation of the accessory doors and drawers, refer to Outdoor Accessories on the following pages.

Burner Module

INSTALLATION

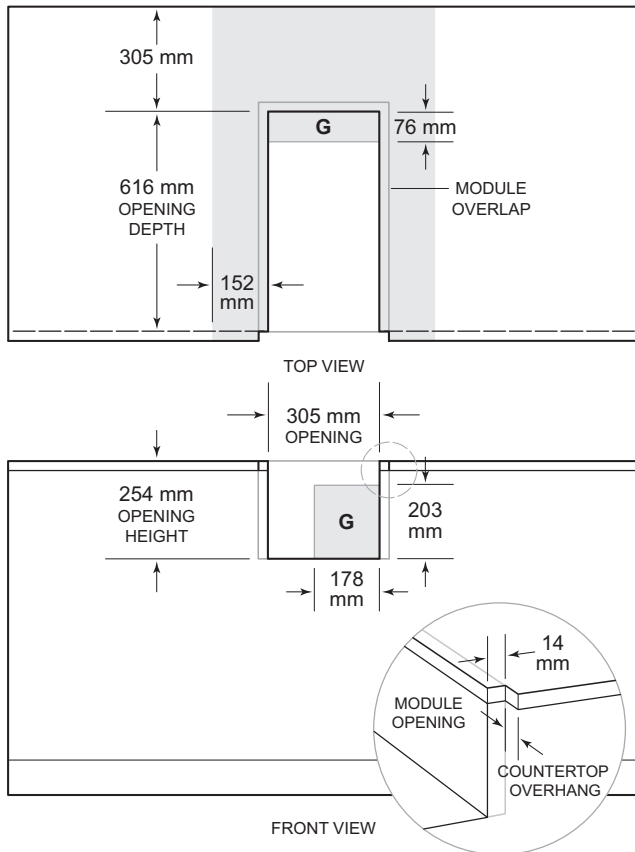

NOTE: Shaded area above countertop indicates minimum clearance to combustible surfaces, combustible materials cannot be located within this area. An insulating liner is not required.

Outdoor Accessories

ACCESS DOORS

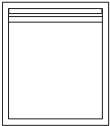

SINGLE

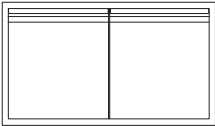

DOUBLE

ACCESSORY DRAWERS AND DOORS

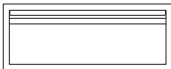

SINGLE DRAWER

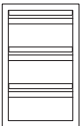

2- OR 3-DRAWER

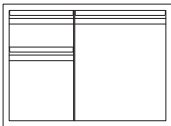

DOOR/DRAWER

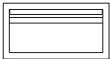

PAPER TOWEL DRAWER

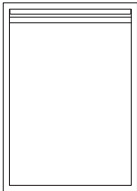

TALL DRY STORAGE

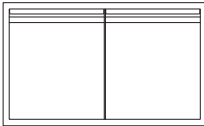

SHORT DRY STORAGE

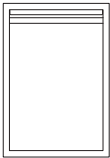

TRASH/RECYCLING DRAWER

Access Doors

DIMENSIONS

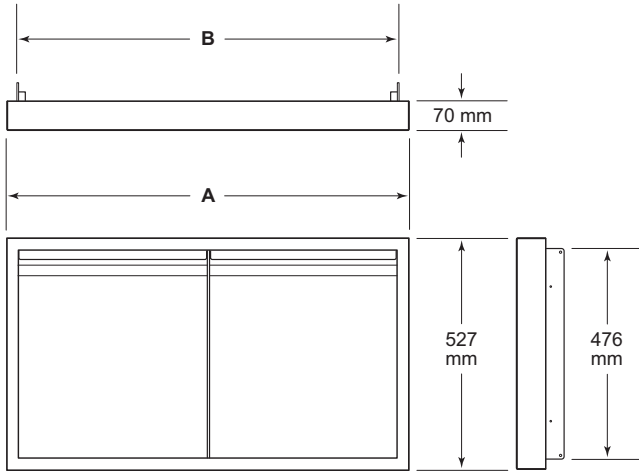

DOOR WIDTH	A	B
46 cm Single	457 mm	413 mm
76 cm Double	762 mm	718 mm
91 cm Double	914 mm	870 mm
107 cm Double	1067 mm	1022 mm
137 cm Double	1372 mm	1327 mm

INSTALLATION

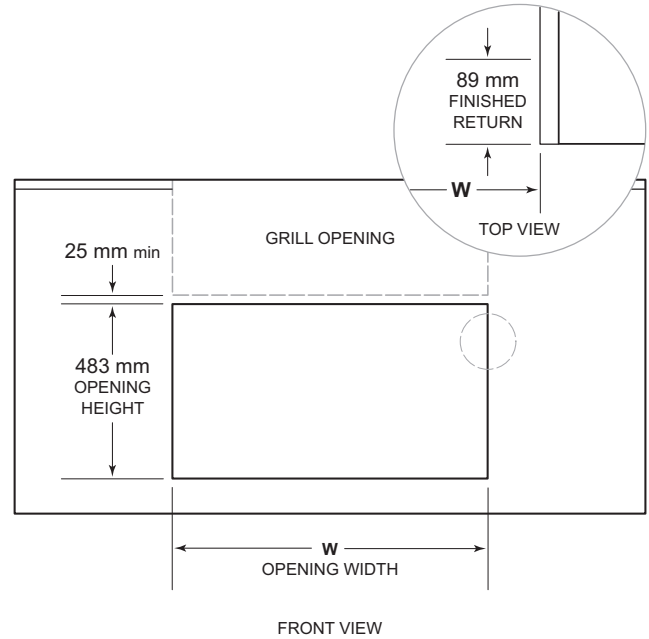

OPENING WIDTH	W
46 cm Single	419 mm
76 cm Double	724 mm
91 cm Double	876 mm
107 cm Double	1029 mm
137 cm Double	1334 mm

IMPORTANT NOTE: The opening dimensions provided are for a standard installation. For a flush installation, refer to the overall dimensions and adjust the opening dimensions accordingly.

Accessory Drawers and Doors

SINGLE DRAWER

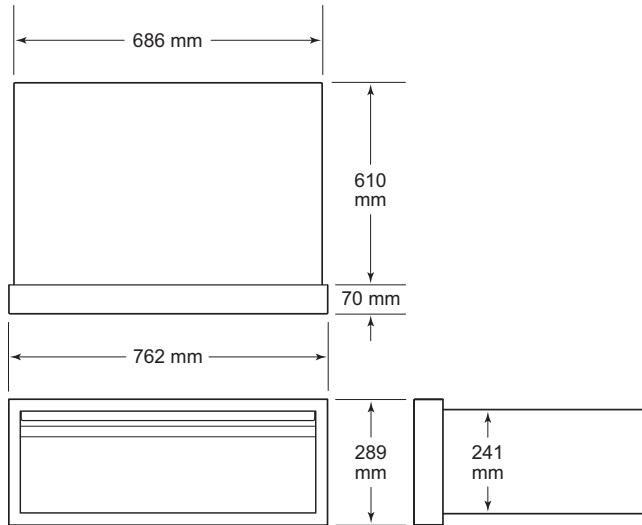

2- OR 3-DRAWER

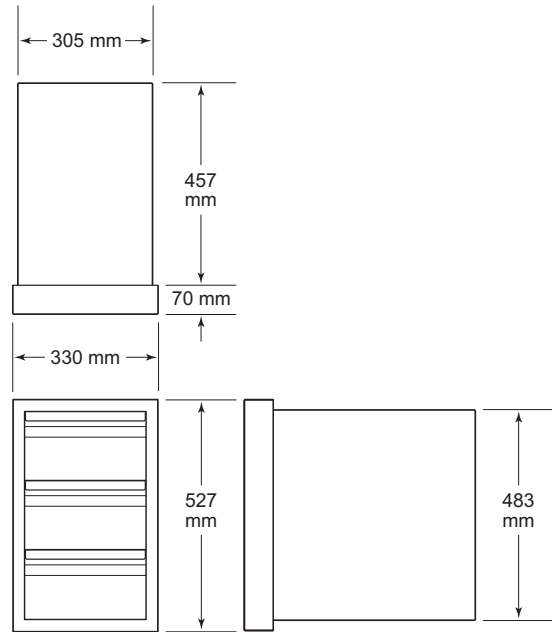

PAPER TOWEL DRAWER

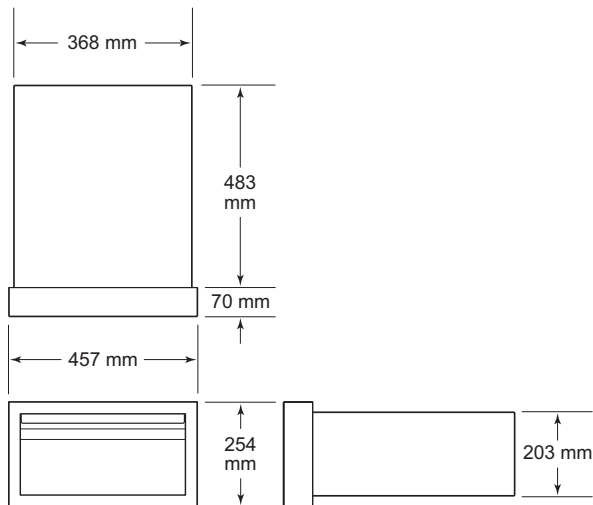

DRAWER/DOOR

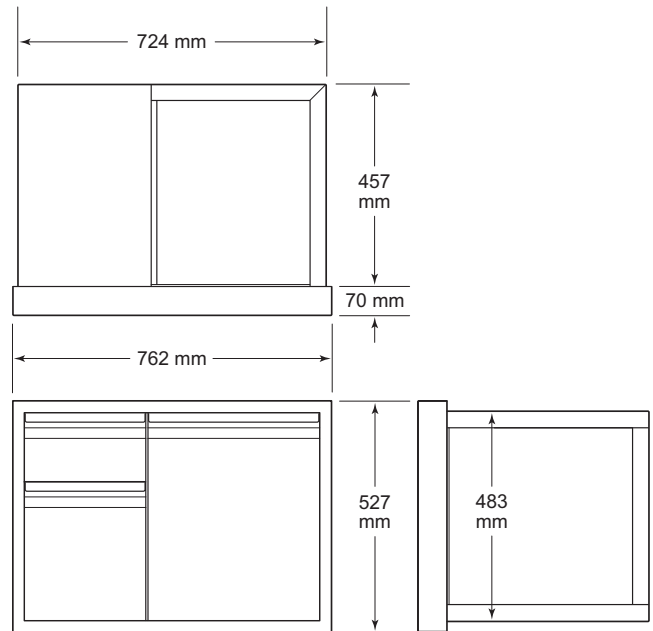

Accessory Drawers and Doors

TALL DRY STORAGE

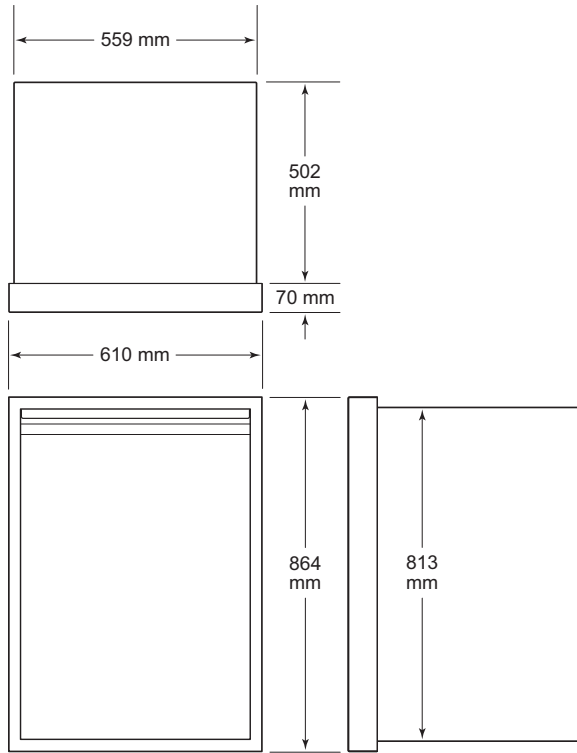

TRASH/RECYCLE DRAWER

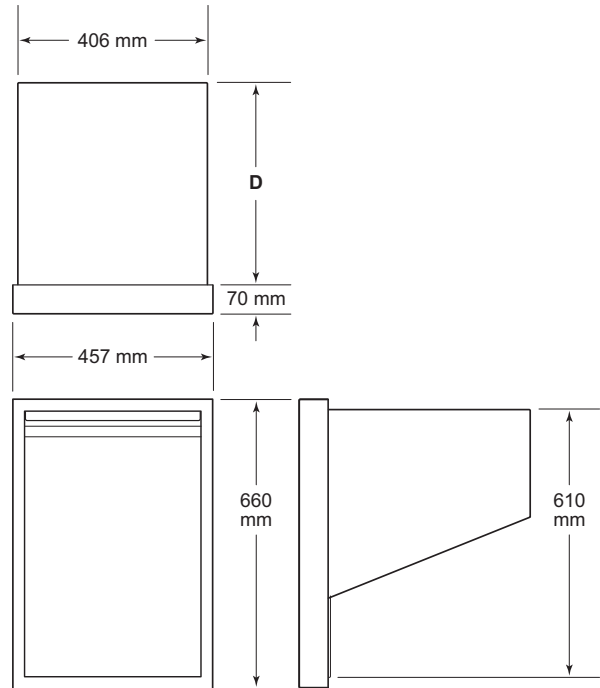

DEPTH	D
Single	495 mm
Double	572 mm

SHORT DRY STORAGE

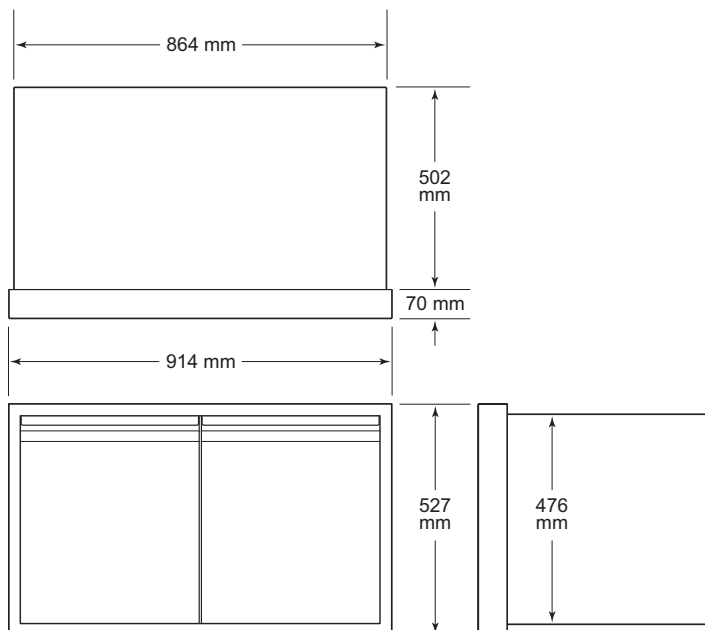

Accessory Drawers and Doors

INSTALLATION

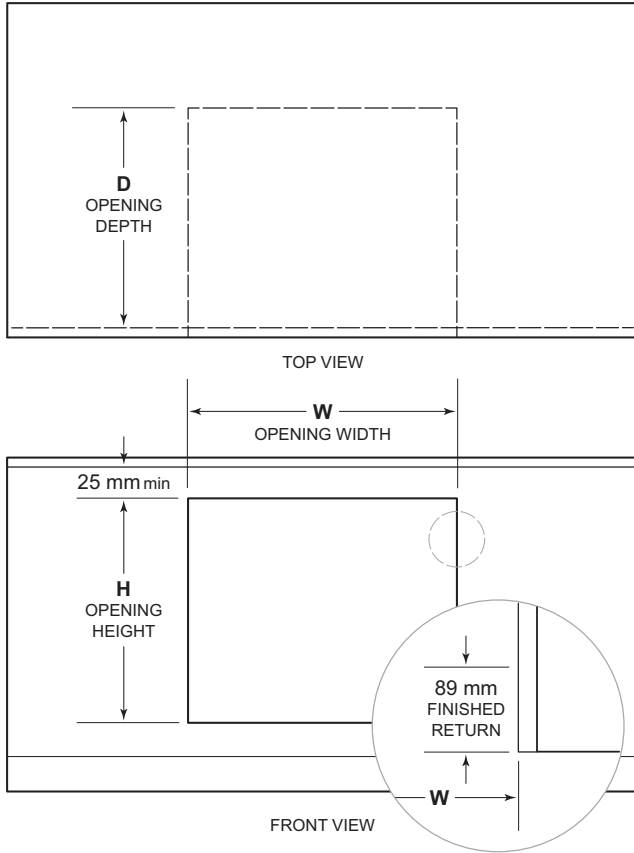

OPENING	W	H	D
Single Drawer	692 mm	248 mm	616 mm
Paper Towel Drawer	375 mm	210 mm	489 mm
2- or 3-Drawer	311 mm	489 mm	464 mm
Drawer/Door	730 mm	489 mm	464 mm
Tall Dry Storage	565 mm	819 mm	508 mm
Short Dry Storage	870 mm	483 mm	508 mm
Single Trash/Recycle	413 mm	616 mm	502 mm
Double Trash/Recycle	413 mm	616 mm	578 mm

BASE SUPPORT	MIN
2- or 3-Drawer	68 kg
Drawer/Door	68 kg
Dry Storage	136 kg

IMPORTANT NOTE: The opening dimensions provided are for a standard installation. For a flush installation, refer to the overall dimensions and adjust the opening dimensions accordingly.

Cooktop Ventilation Hoods

The new generation of Wolf Cooktop Ventilation Hoods feature two new looks—black and stainless. Brilliant LED lighting illuminates your cooking surface while powerful multi-speed blowers whisk away smoke and odors. The dishwasher-safe filters can be removed easily for cleaning. The wall-mount and island hoods are crafted of stainless steel.

COOKTOP VENTILATION HOODS

BLACK

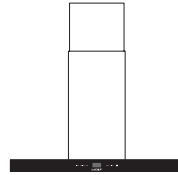

ICBVW36B WALL

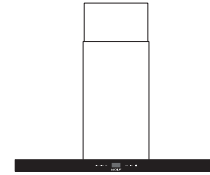

ICBVI42B ISLAND

STAINLESS

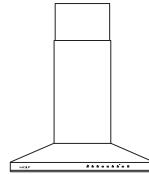

ICBVW30S WALL

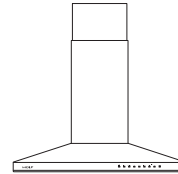

ICBVW36S WALL

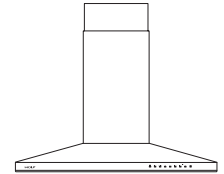

ICBVI42S ISLAND

Cooktop Ventilation Hoods

WALL HOODS—BLACK

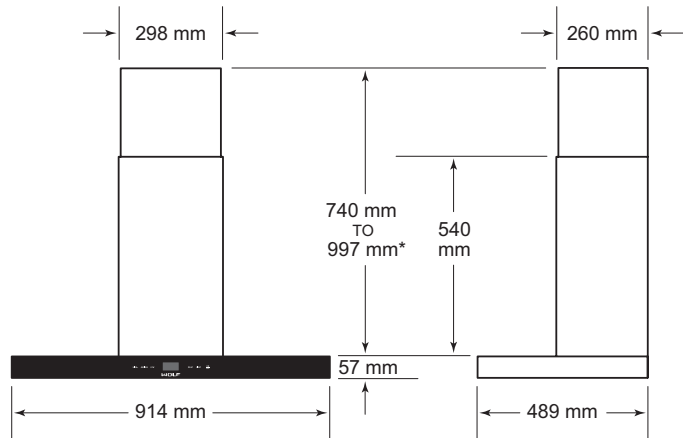

*1248 mm to 1505 mm with accessory flue extension.

ISLAND HOOD—BLACK

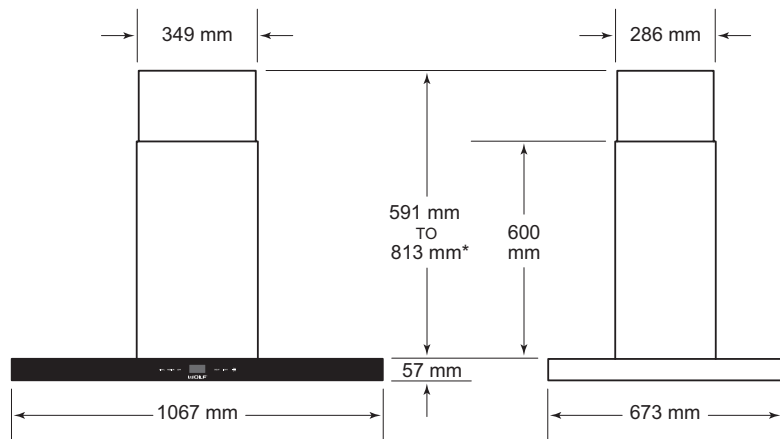

*1175 mm to 1397 mm with accessory flue extension.

Cooktop Hoods

Cooktop Ventilation Hoods

WALL HOODS—STAINLESS

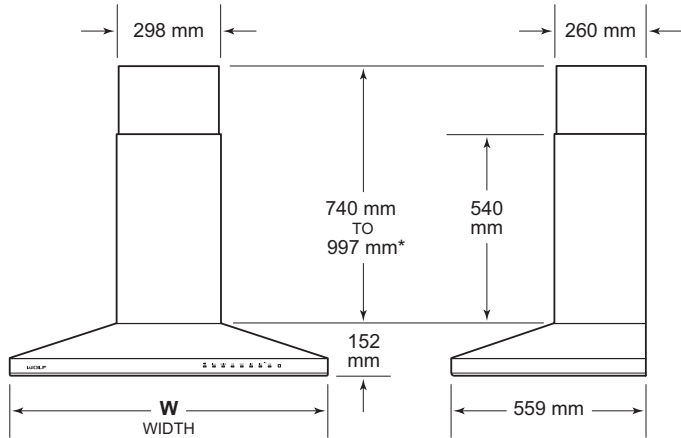

*1248 mm to 1505 mm with accessory flue extension.

WIDTH	W
ICBVW30S	762 mm
ICBVW36S	914 mm

ISLAND HOOD—STAINLESS

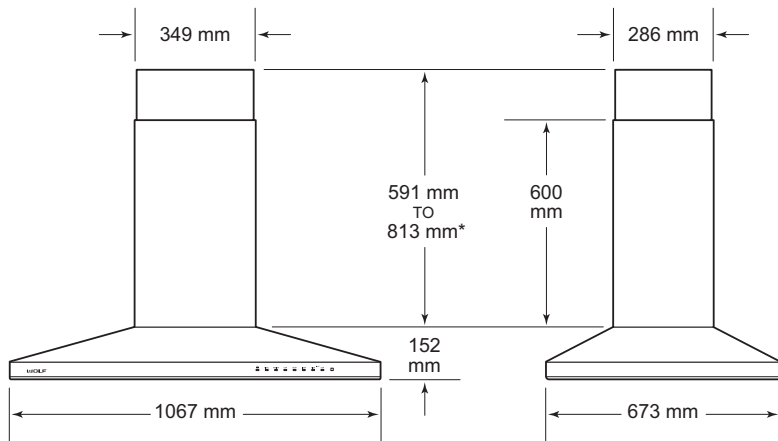

*1175 mm to 1397 mm with accessory flue extension.

Planning Information

Wolf Cooktop Ventilation Hoods are recommended for use with Wolf Induction and Gas Cooktops, and Modules. For Wolf Ranges and Rangetops, a Wolf Pro Ventilation hood is recommended.

These hoods have a telescopic chimney flue. A flue extension is available through an authorized Wolf dealer.

Installation of the Cooktop Hood should be 762 mm to 914 mm from the bottom of the hood to the countertop.

Wall and island hoods require an internal or remote blower assembly, available through an authorized Wolf dealer. Refer to Ventilation Suggestions on pages 106–108.

Cooktop Hoods have a vertical discharge with 152 mm round duct.

Consult a qualified HVAC professional for specific installation and ducting applications.

ELECTRICAL REQUIREMENTS

Installation must comply with all applicable electrical codes and be properly grounded (earthed).

For wall hoods, locate the electrical supply within the shaded area shown in the illustration below. For island hoods, locate the electrical supply on the ceiling inside the top of the hood. A separate circuit servicing only this appliance is recommended.

ELECTRICAL REQUIREMENTS

Electrical Supply	220-240 V AC, 50 Hz 220 V AC, 60 Hz
Service	1.9 A

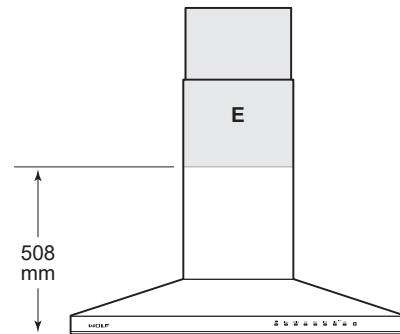

762 mm TO 914 mm BOTTOM EDGE TO COUNTERTOP

Electrical location for all wall hoods

Ceiling-Mounted Hood

The new Ceiling-Mounted Hood is our most contemporary ventilation offering, nearly disappearing into its surroundings. It comes in two widths and is available in stainless steel. The hood ships with a remote control and can be operated using the remote control or the control panel. The control panel is recessed into the right side of the hood. The dishwasher-safe filters can be removed easily for cleaning.

CEILING-MOUNTED HOODS

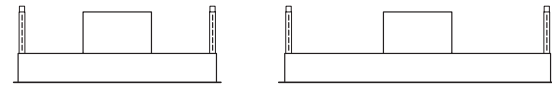

ICBVC36S

ICBVC48S

DIMENSIONS

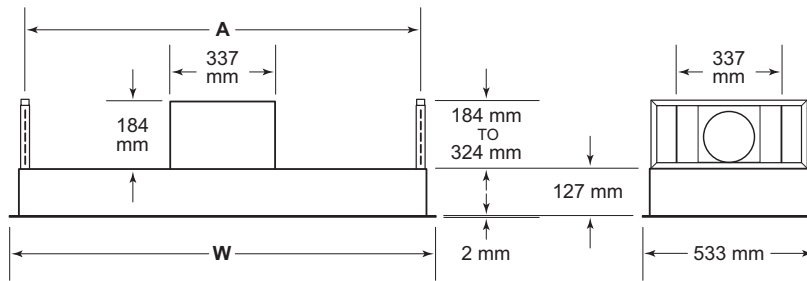

DIMENSIONS	W	A
91 cm Hood	902 mm	841 mm
122 cm Hood	1200 mm	1121 mm

Planning Information

Installation of the Ceiling-Mounted Hood should be 914 mm to 2134 mm from the bottom of the hood to the countertop.

The hood can be operated using the remote control or the control panel located on the right side of the hood.

The hood is shipped without a blower assembly. A 900 CMH internal blower is available through an authorized Wolf dealer. Refer to Ventilation Suggestions on pages 106–108.

The Ceiling-Mounted Hood includes a 152 mm round discharge for the internal blower. The blower box can be rotated to discharge right, left, front, or rear.

Consult a qualified HVAC professional for specific installation and ducting applications.

RECIRCULATING INSTALLATION

The Ceiling-Mounted Hood with internal blower can be installed in a recirculating application. The air discharge must be a minimum of 1016 mm from every side of the hood. Refer to the illustration below. The ductwork and vent cover are not provided. A recirculation kit, available through an authorized Wolf dealer, is required.

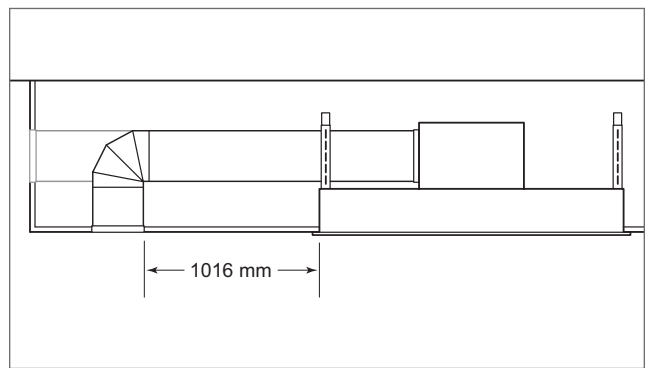

Recirculation application

Planning Information

ELECTRICAL REQUIREMENTS

Installation must comply with all applicable electrical codes and be properly grounded (earthed).

Locate the electrical supply within the shaded area shown in the illustration below. Allow a minimum 305 mm electrical cable for connection. A separate circuit servicing only this appliance is required.

ELECTRICAL REQUIREMENTS

Electrical Supply	220-240 V AC, 50 Hz 220 V AC, 60 Hz
Service	1.9 A

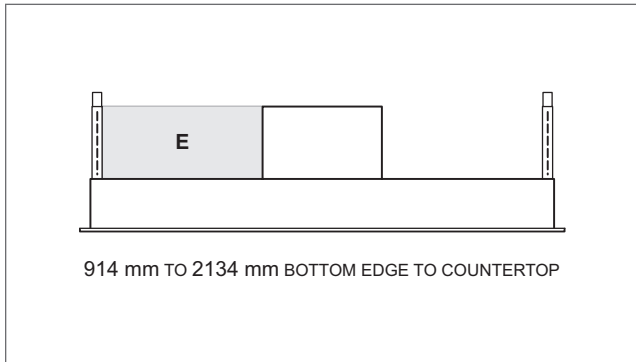

Electrical location

Opening Dimensions

CEILING-MOUNTED HOOD

Refer to the chart and illustrations below for opening dimensions and typical framing. Framing must be able to support a minimum of 45 kg.

HOOD	W
91 cm Hood	873 mm
122 cm Hood	1175 mm

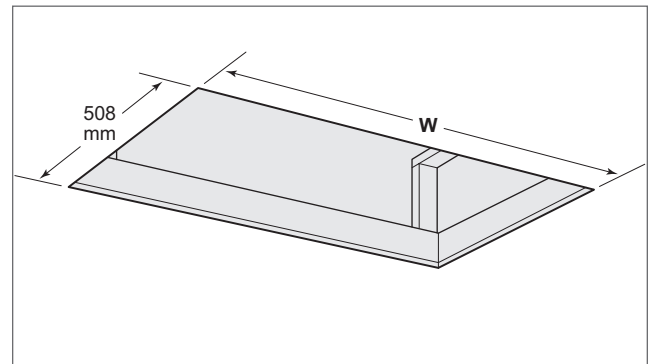

Opening dimensions

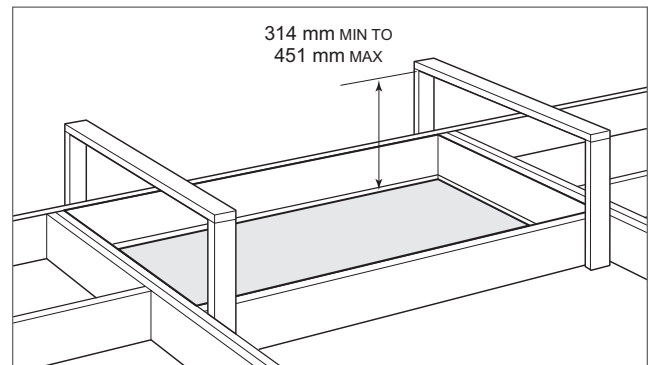

Support framing (typical)

Downdraft Ventilation

Constructed of heavy duty stainless steel, the Wolf Down-draft rises from the countertop to whisk away odor and smoke into stainless steel, mesh filters and can be lowered beneath the countertop when not in use.

DOWNDRAFT

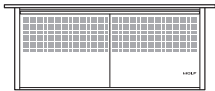

ICBDD36

Downdraft

DIMENSIONS

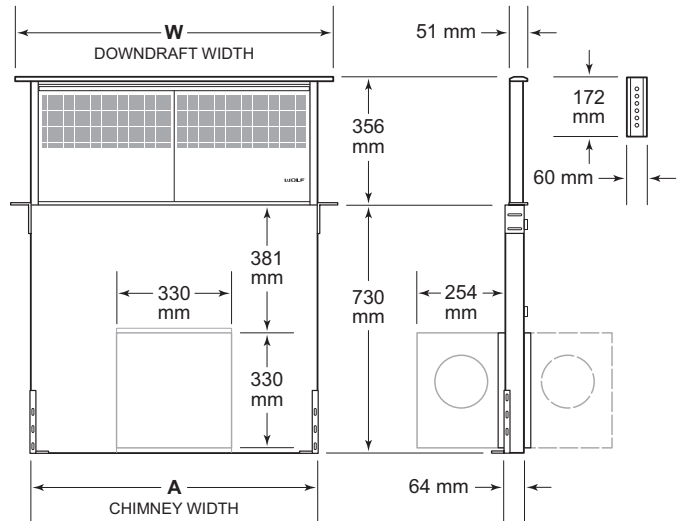

NOTE: Shown with front mounted internal blower with 152 mm round discharge, dashed line represents rear mount.

WIDTH	W	A
ICBDD36	914 mm	826 mm

Planning Information

Wolf Downdrafts can be installed with most Wolf Cooktops, but are not compatible with the Grill and Steamer Modules. Contact an authorized Wolf dealer for details.

For installation with a Wolf Cooktop, a minimum 638 mm deep flat countertop is required.

The remote-mounted control module must be located within 2.7 m of the Downdraft assembly and a minimum 76 mm from the edge of the cooktop cutout.

BLOWERS

Internal and remote blowers are available through an authorized Wolf dealer. Refer to Ventilation Suggestions on pages 106–108.

Internal blowers include a 152 mm round discharge and can be front or rear mounted. It can be discharged in any direction by rotating the blower box. Remote blowers include a 254 mm discharge and can be discharged from the front or rear.

Consult a qualified HVAC professional for specific installation and ducting applications.

ELECTRICAL REQUIREMENTS

Installation must comply with all applicable electrical codes and be properly grounded (earthed).

Locate the electrical supply as shown in the illustrations on the following pages. A separate circuit servicing only this appliance is required. A ground fault circuit interrupter (GFCI) is not recommended and may cause interruption of operation.

Certain installations may require that the electrical supply be placed in an adjacent cabinet.

ELECTRICAL REQUIREMENTS

Electrical Supply	220-240 V AC, 50 Hz 220 V AC, 60 Hz
Service	1.9 A
Receptacle	grounding-type (earthed)
Power Cord	.8 m

Downdraft

INSTALLATION WITH STANDARD INSTALLED COOKTOP

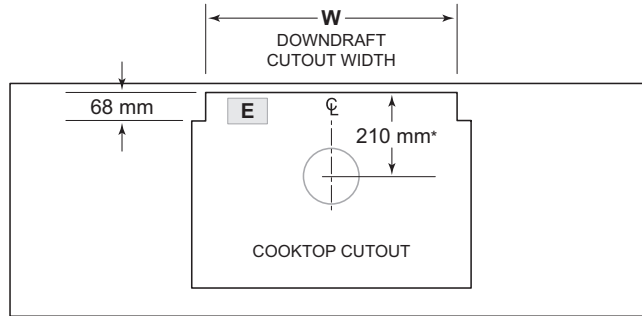

TOP VIEW

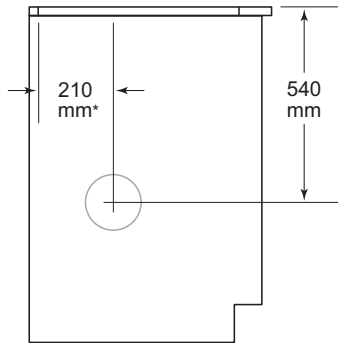

SIDE VIEW

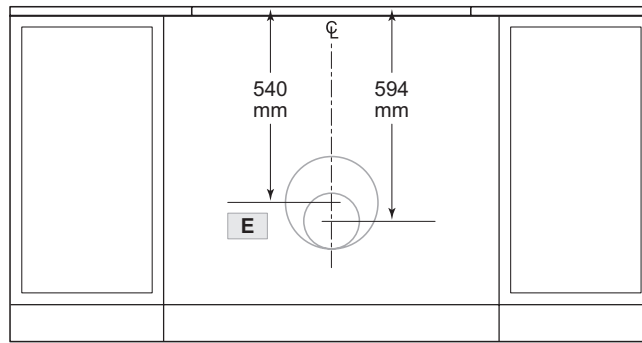

FRONT VIEW

*152 mm back from countertop cutout when internal blower is rear mounted.

NOTE: Internal blower 152 mm round, side, rear or bottom discharge. Remote blower 254 mm round, rear discharge. Centerline indicates center of downdraft cutout.

CUTOUT WIDTH	W
ICBDD36	851 mm

Downdraft

INSTALLATION WITH FLUSH INSTALLED COOKTOP

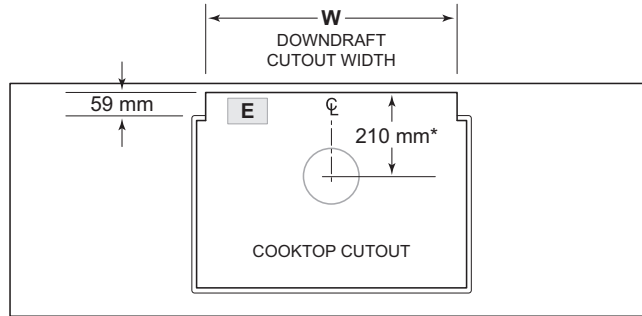

TOP VIEW

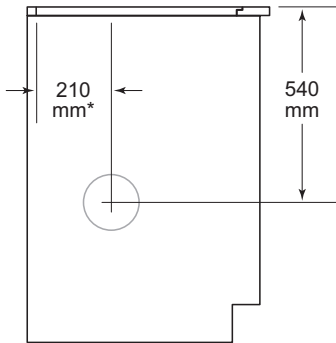

SIDE VIEW

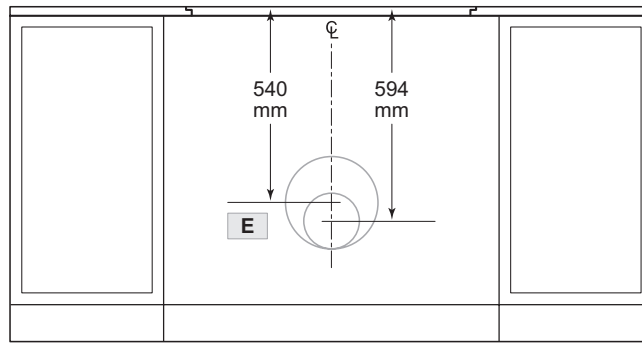

FRONT VIEW

*152 mm back from countertop cutout when internal blower is rear mounted.

NOTE: Internal blower 152 mm round, side, rear, or bottom discharge. In-line and remote blower 254 mm round, rear discharge. Centerline indicates center of downdraft cutout.

CUTOUT WIDTH	W
ICBDD36	851 mm

Pro Ventilation Hoods

Professional heritage shines through in Wolf professional-style ventilation. Exteriors are heavy-duty, welded stainless steel, so finely hand-finished that they appear seamless. Pro Wall Hoods are available in 61 cm and 69 cm depths and a variety of widths. Stainless steel baffle filters and halogen lighting extend the professional look and back it up with pro-level performance. All Pro Ventilation Hoods are crafted of stainless steel.

PRO HOODS

WALL HOODS

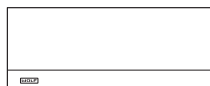

61 cm / 69 cm DEEP

Pro Hoods

61 cm DEEP WALL HOOD

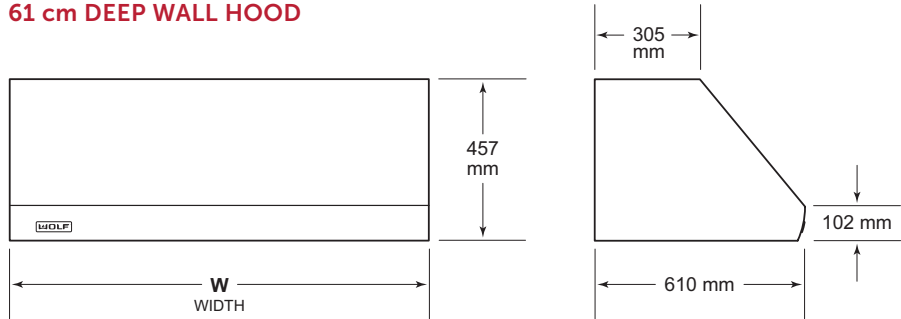

69 cm DEEP WALL HOOD

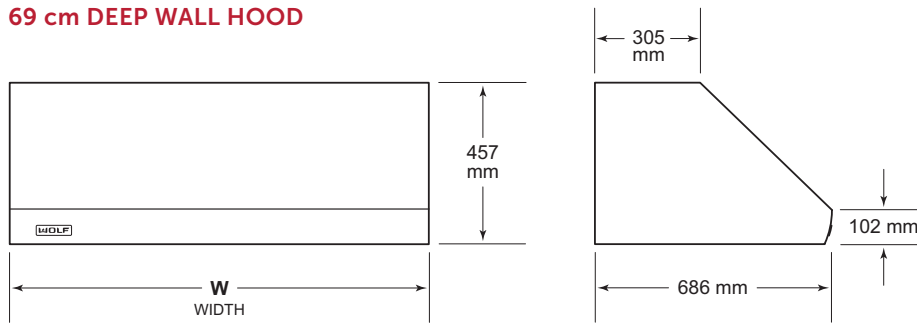

WIDTH

61 cm DEEP WALL HOOD	W
	914 mm, 1219 mm

69 cm DEEP WALL HOOD	W
	1219 mm, 1524 mm

Planning Information

Pro Ventilation Hoods are recommended for use with all Wolf cooking appliances. Wall hoods should be at least as wide as the cooking surface.

For optimal performance in wall hood applications, a pro 69 cm deep wall hood is recommended for use with ranges and rangetops with a charbroiler or griddle.

Installation of the hood should be 762 mm to 914 mm from the bottom of the hood to the countertop.

Pro Ventilation Hoods are shipped without a blower assembly. Remote blowers are available through an authorized Wolf dealer. The blower will vary in size and is dictated by the cooking unit, volume of air, and length of the duct run. Refer to Ventilation Suggestions on pages 106–108.

Pro Hoods accommodate a 254 mm round duct and have a vertical discharge. For the 61 cm and 69 cm deep wall hoods, a horizontal discharge kit is available through an authorized Wolf dealer.

Consult a qualified HVAC professional for specific installation and ducting applications.

Optional stainless steel duct covers in a variety of heights are available for Pro Wall Hoods through an authorized Wolf dealer.

ELECTRICAL REQUIREMENTS

Installation must comply with all applicable electrical codes and be properly grounded (earthed).

Locate the electrical supply within the shaded area shown in the illustration on the following page. Allow a minimum 305 mm electrical cable for connection. A separate circuit servicing only this appliance is required.

ELECTRICAL REQUIREMENTS

Electrical Supply	220-240 V AC, 50 Hz 220 V AC, 60 Hz
Service	1.9 A

Installation

61 cm / 69 cm DEEP WALL HOODS

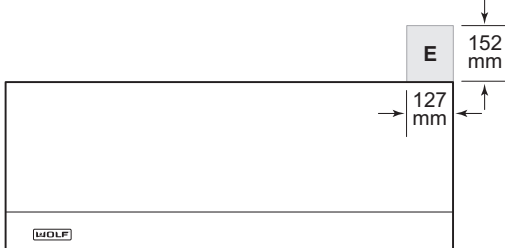

762 mm TO 914 mm BOTTOM EDGE TO COUNTERTOP

Blower Assemblies

For Wolf Ventilation Hoods and Downdrafts that do not include a blower assembly, an internal or remote blower assembly must be selected to accommodate the cooking appliance, CMH requirements, and homeowner preferences. Internal and remote blowers are available through an authorized Wolf dealer.

Ventilation Suggestions on the following pages provide Wolf product CMH and blower options for each Ventilation Hood and Downdraft.

Refer to the illustration below for dimensions of the Wolf remote blower. Installation instructions shipped with each Wolf ventilation product provide detailed specifications.

1528 CMH REMOTE

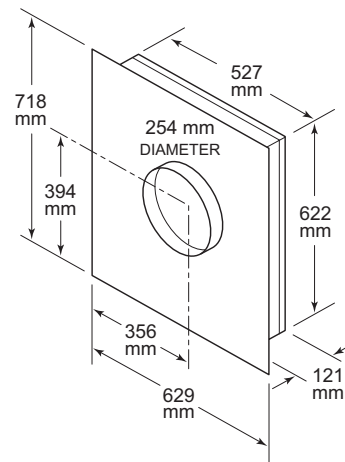

Ventilation Suggestions

Wolf Product CMH

CMH	COOKTOP HOOD	DOWNDRAFT	PRO HOOD
COOKTOP / MODULE			
ICBCI152TF/S ICBCG152TF/S	900	900	1528
ICBSM15TF/S ICBGM15TF/S	900		1528
ICBMM15TF/S	900	900	1528
ICBCI243TF/S	900		1528
ICBCI304TF/S	900	900	1528
ICBCI304C/B ICBCI30460C/B	900		1528
ICBCG304T/S ICBCG304P/S	900	900	1528
ICBCI365TF/S	900	900	1528
ICBCI365C/B ICBCI36560C/B	900		1528
ICBCG365T/S ICBCG365P/S	900	900	1528
DUAL FUEL RANGE			
ICBDF30450 ICBDF36650			1528
ICBDF36450G			1528
ICBDF48850 ICBDF48650G ICBDF48450CG ICBDF48450DG			1859
ICBDF60650CG ICBDF60650DG			1859
INDUCTION RANGE			
ICBIR30450	900		1528
ICBIR36550	900		1528
SEALED BURNER RANGETOP			
ICBSRT364G ICBSRT362W			1528
ICBSRT486G ICBSRT484CG ICBSRT484W			1528

Ventilation Suggestions

Wolf Ventilation Blower Options

BLOWER	INTERNAL	REMOTE
CMH	900	1528
COOKTOP HOOD		
ICBVW36B ICBVI42B	•	•
ICBVW30S ICBVW36S ICBVI42S	•	•
ICBVC36S ICBVC48S	•	
DOWNDRAFT		
ICBDD36	•	•
PRO 61 cm DEEP WALL HOOD		
ICBPW362418		•
ICBPW482418		•
PRO 69 cm DEEP WALL HOOD		
ICBPW482718		•
ICBPW602718		•

Wolf Appliance International Limited Warranty

FOR RESIDENTIAL USE

FULL TWO YEAR WARRANTY*

For two years from the date of original installation, this Wolf Appliance product warranty covers all parts and labor to repair or replace, under normal residential use, any part of the product that proves to be defective in materials or workmanship. All service provided by Wolf Appliance under the above warranty must be performed by Wolf Factory Certified Service, unless otherwise specified by Wolf Appliance, Inc. Service will be provided during normal business hours.

LIMITED THIRD THROUGH FIFTH YEAR WARRANTY

For five years from the date of original installation, Wolf Appliance will repair or replace the following parts that prove to be defective in materials or workmanship: gas burners (excluding appearance), electric heating elements, blower motors (ventilation hoods), electronic control boards, magnetron tubes and induction generators. The part(s) will be repaired or replaced, free of charge, with the owner paying for all other costs including labor. All service provided by Wolf Appliance under the above warranty must be performed by Wolf Factory Certified Service, unless otherwise specified by Wolf Appliance, Inc. Service will be provided during normal business hours.

For more information regarding your Wolf product warranty, contact your authorized Wolf dealer. Warranties must comply to all country, state, city, local and or ordinance.

*Stainless steel (doors, panels, handles, product frames and interior surfaces) are covered by a limited 60-day parts and labor warranty for cosmetic defects.



Wolf Appliance International Outdoor Limited Warranty*

FOR RESIDENTIAL USE

FULL ONE YEAR WARRANTY**

For one year from the date of original installation, this Wolf Appliance product warranty covers all parts and labor to repair or replace, under normal residential use, any part of the product that proves to be defective in materials or workmanship. All service provided by Wolf Appliance under the above warranty must be performed by Wolf Factory Certified Service, unless otherwise specified by Wolf Appliance, Inc. Service will be provided during normal business hours.

LIMITED FIVE YEAR WARRANTY

For five years from the date of original installation, Wolf Appliance will repair or replace the following parts that prove to be defective in materials or workmanship: stainless steel briquette trays, gas valves, drip pans, electronic control boards and electric heating elements. If the owner uses Wolf Factory Certified Service, the service provider will repair or replace these parts with the owner paying for all other costs, including labor. If the owner uses non-certified service, the owner must contact Wolf Appliance, Inc. (using the information below) to receive repaired or replacement parts. Wolf Appliance will not reimburse the owner for parts purchased from non-certified service or other sources.

For more information regarding your Wolf product warranty, contact your authorized Wolf dealer. Warranties must comply to all country, state, city, local and or ordinance.

*Product must be approved for outdoor use, designated by model and serial number.

**Stainless steel (doors, panels, handles, product frames and interior surfaces) are covered by a limited 60-day parts and labor warranty for cosmetic defects.





WOLFAPPLIANCE.COM